

# Body Repair Manual NEW RANGE ROVER



**This manual covers vehicles from  
introduction 1995**

01	INTRODUCTION
04	GENERAL SPECIFICATION DATA
60	FRONT SUSPENSION
75	SUPPLEMENTARY RESTRAINT SYSTEM
76	CHASSIS AND BODY
77	PANEL REPAIRS



01  
04



60



75  
76



77

Published by Rover Technical Communication  
P O Box 47, Cowley, OXFORD, OX45NL

© 1996 Rover Group Limited  
Publication part no. LRL 0085ENG



---

## INTRODUCTION

---

This Body Repair Manual is designed to provide the experienced bodyshop technician with the information required to carry out efficient and cost effective repairs.

To assist in the use of this Manual, the section title is given at the top and the relevant sub-section at the bottom of each page.

The individual items comprising operations are to be followed in the sequence in which they appear, see **BODY** and **SRS** sections. Items numbers in the illustration are referred to in the text. Adjustment and repair operations include reference to Service Tool numbers. Each adjustment or repair operation is given its Service Repair Operation number.

The repair operations cover replacement of the relevant welded panels and panel assemblies on the vehicle, see **PANEL REPAIRS**. The sequence of operations progresses from the front to the rear of the vehicle. Each operation details any special points to observe when replacing a welded panel, together with cross-references to the relevant trim items to be removed and replaced for access.

---

## DIMENSIONS

---

The dimensions quoted are to design engineering specification with service limits where applicable.

---

## REFERENCES

---

References to the LH or RH side given in this Manual are made when viewing the vehicle from the rear. With the engine and gearbox assembly removed, the water pump end of the engine is referred to as the front.

WARNINGS, CAUTIONS and NOTES have the following meanings:



**WARNING: Procedures which must be followed precisely to avoid the possibility of injury.**



**CAUTION: Calls attention to procedures which must be followed to avoid damage to components.**



**NOTE: Gives helpful information.**

---

## REPAIRS AND REPLACEMENTS

---

When replacement parts are required it is essential that Land Rover parts are used. Attention is particularly drawn to the following points concerning repairs and the fitting of replacement parts and accessories: Safety features embodied in the vehicle may be impaired if other than Land Rover parts are fitted. In certain territories, legislation prohibits the fitting of parts not to the vehicle manufacturer's specification. Torque spanner values given in the Workshop Manual must be strictly adhered to. Locking devices, where specified, must be fitted. If the efficiency of a locking device is impaired during removal it must be replaced with a new one. Certain fasteners must not be re-used. These fasteners are specified in the Workshop Manual.

Owners purchasing accessories while travelling abroad should ensure that the accessory and its fitted location on the car conform to legal requirements.

The terms of the vehicle Warranty may be invalidated by the fitting of other than Land Rover recommended parts.

All Land Rover recommended parts have the full backing of the vehicle Warranty.

Land Rover dealers are obliged to supply only Land Rover recommended parts.

---

**SPECIFICATION**

---

Land Rover are constantly seeking to improve the specification, design and production of their vehicles and alterations take place accordingly. While every effort has been made to ensure the accuracy of this Manual, it should not be regarded as an infallible guide to current specifications of any particular vehicle.

This Manual does not constitute an offer for sale of any particular vehicle. Land Rover dealers are not agents of Land Rover and have no authority to bind the manufacturer by any expressed or implied undertaking or representation.

**ALIGNMENT JIG DIMENSIONS**

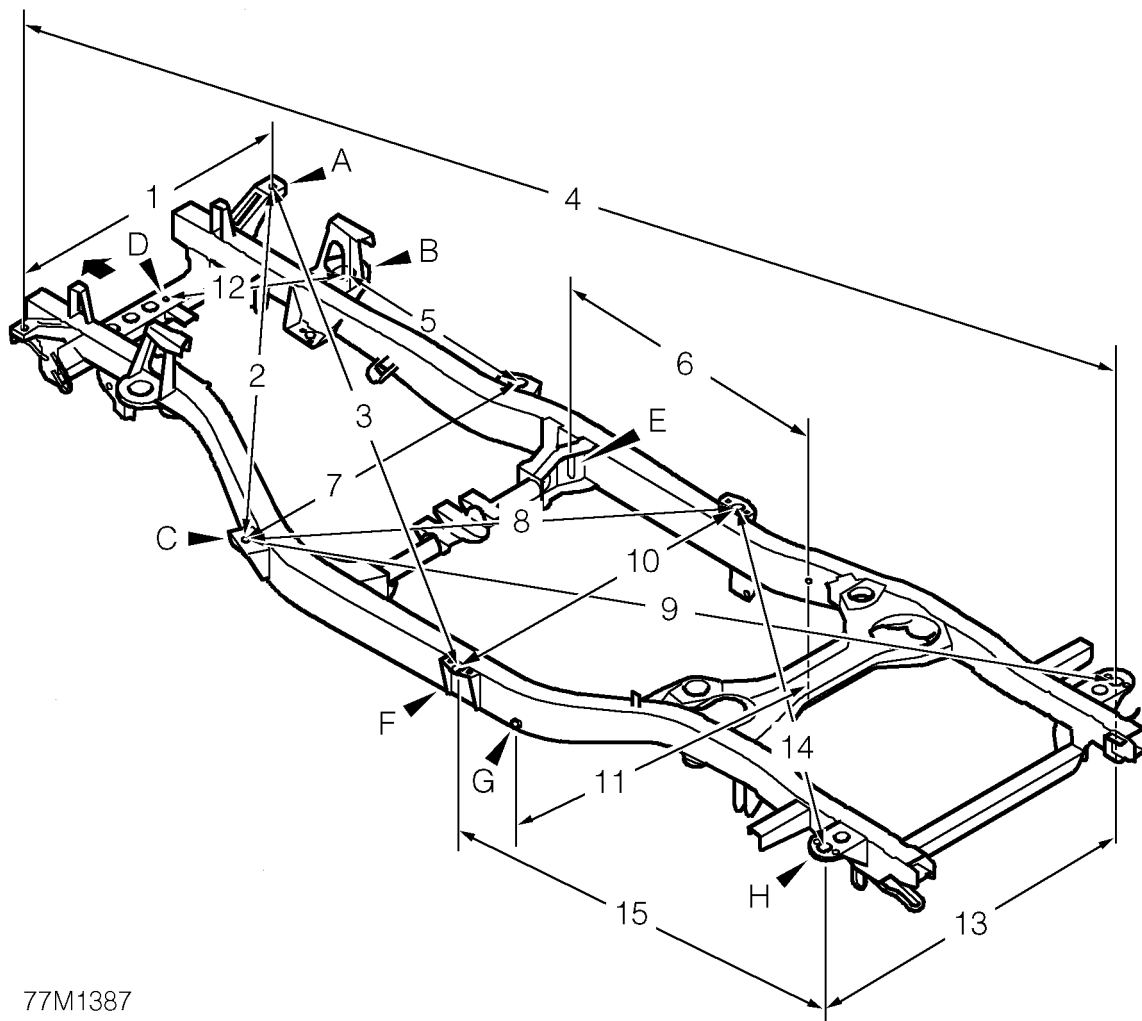

77M1387

- 1. 1190mm (46.8in.)
- 2. 1709mm (67.3in.)
- 3. 2527mm (99.6in.)
- 4. 4173mm (164.4in.)
- 5. 717mm (28.3in.)
- 6. 982.5mm (38.7in.)
- 7. 1328mm (52.3in.)
- 8. 1697mm (66.9in.)
- 9. 3159mm (124.5in.)
- 10. 1340mm (52.8in.)
- 11. 1302mm (51.3in.)
- 12. 665mm (26.2in.)

- 13. 1400mm (55.2in.)
- 14. 2364mm (93.1in.)
- 15. 1803mm (71.0in.)

- A = No. 1 body mount RH and LH
- B = Front spring seat RH and LH
- C = No. 2 body mount RH and LH
- D = Front crossmember piercing RH and LH
- E = Front radius arm mounting bracket RH and LH
- F = No. 3 body mount RH and LH
- G = Rear composite link mounting bracket RH and LH
- H = No. 5 body mount RH and LH

All dimensions taken at centre line of set screw or set screw hole.

### **Straightening**

Whenever possible, structural members should be cold straightened under tension. Do not attempt to straighten with a single pull, but rework the damaged area using a series of pulls, releasing tension between each stage and using the opportunity to check alignment.

### **Body jig**

Unless damage is limited to cosmetic panels, all repair work to body members must be carried out on a body jig, to ensure that impact damage has not spread into more remote parts of the body structure. Mounting on a jig will also ensure that the straightening and panel replacement procedures do not cause further distortion. If original dimensions cannot be satisfactorily restored by these methods, damaged structural members should be replaced. Damaged areas should be cut away using a high speed saw, NOT an oxy-acetylene torch.

As a rule, body dimensions are symmetrical about the centre line. A good initial check for distortion is therefore to measure diagonally and to investigate apparent differences in dimensions.

### **Inspection**

Every accident produces individual differences in damage. Each repair is influenced by the extent of the damage and by the facilities and equipment available for its rectification.

Most accident damage can be visually inspected and the approximate extent of the damage assessed. Sometimes deformation will extend beyond the area of direct damage, and the severity of this must be accurately established so that steps may be taken to restore critical body components to their original dimensions.

An initial check of critical dimensions can be carried out by means of drop checks or (preferably) trammels. Gauges are available which will check accurately for body twist. Where repairs necessitate renewal of a critical body component it is recommended that a body jig is used.



**VEHICLE IDENTIFICATION NUMBER (VIN)**

An adhesive label containing the Vehicle Identification Number and the recommended maximum vehicle weights is located on the left hand side of the bonnet locking platform.

The number is also stamped on the right side of the chassis forward of the spring mounting turret.

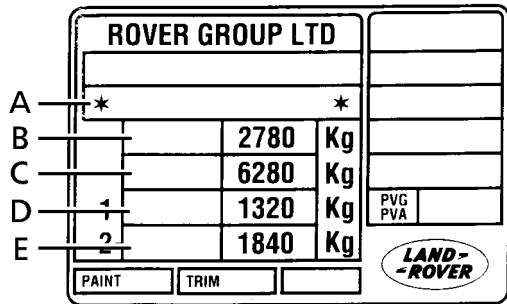

1M7003

**Federal (USA) vehicle identification number**

An adhesive label containing the Vehicle Identification Number, date of manufacture and gross axle weight ratings is fixed to the lock face of the front left hand door. The information includes wheel and tyre sizes and tyre pressures at gross axle weight ratings.

**Key to Vehicle Identification Number Plate**

- A. VIN (17 digits)
- B. Maximum permitted laden weight for vehicle
- C. Maximum vehicle and trailer weight
- D. Maximum road weight-front axle
- E. Maximum road weight-rear axle

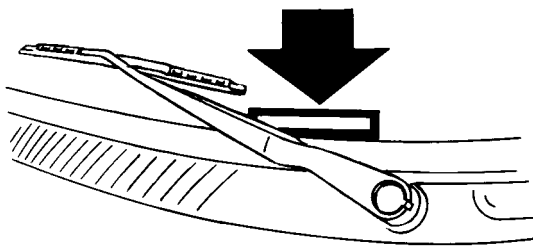

1M7005

In addition the VIN is stamped on a plate which is visible through the left side of the windscreen.

---

**LOCATION OF IDENTIFICATION NUMBERS**



---

**Engine serial number - V8 engine**

Stamped on a cast pad on the cylinder block, between numbers 3 and 5 cylinders.

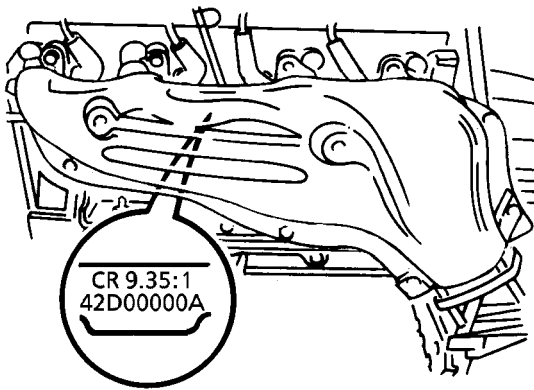

**NOTE: The engine compression ratio is stamped above the serial number.**



1M7006

**Main gearbox R380 - 5 speed**

Stamped on a cast pad on the bottom right hand side of the gearbox.

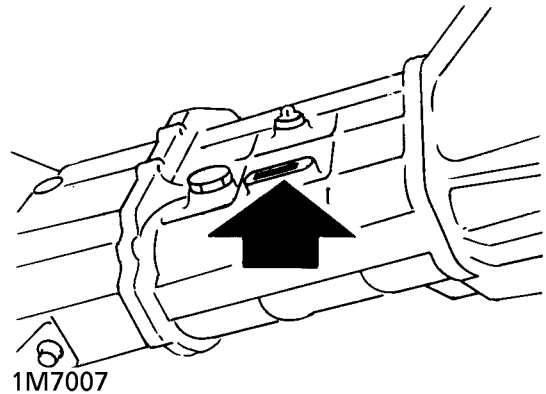
**Automatic gearbox ZF4HP22**

Stamped on a plate riveted to the bottom left hand side of the gearbox casing.

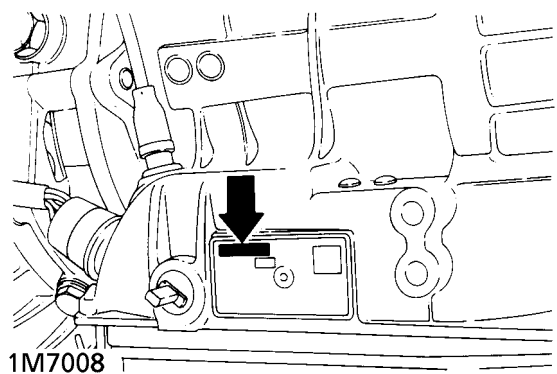
**Engine serial number - BMW Diesel engine**

Stamped on the LH side of the cylinder block above the sump.

### Transfer gearbox-Borg Warner

Stamped on a plate attached to the gearbox casing, between filler/level and drain plug.

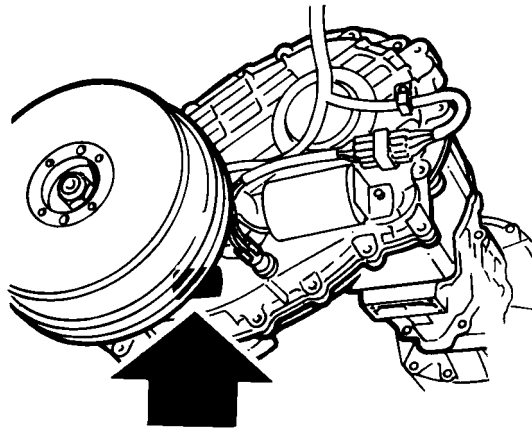

1M7009

### Front and rear axle

Stamped on the left hand axle tubes.

### Vehicle identification number (VIN)

Made up of 17 digits, these numbers are used to identify manufacturer, model range, specification, body type, engine, transmission/steering, model year, plant and build sequence number and serve to identify the vehicle.

This example shows the sequence:

#### European code

S A L L P A M J 7 M A

S Europe  
 AL UK  
 LP Range Rover  
 A European Spec.  
 M 4 Door Station Wagon  
 J 4.6 Litre Fuel Injection  
 7 Manual right steering  
 M 1995 Model Year  
 A Solihull

#### Federal (USA) code

S A L P V 1 2 4 2 S A

S Europe  
 AL UK  
 P Range Rover  
 V North America Spec.  
 1 4 Door Station Wagon  
 2 4.0 Litre fuel injection  
 4 Automatic, Left Hand Steering  
 2 Check Digit  
 S 1995 Model Year  
 A Solihull



---

**SAFETY INSTRUCTIONS**

---

**Jacking**

The recommended jacking points are given in **LIFTING AND TOWING**. Always ensure that any lifting apparatus has adequate load and safety capacity for the weight to be lifted. Ensure the vehicle is standing on level ground prior to lifting or jacking. Apply the handbrake and chock the wheels.

Never rely on a jack as the sole means of support when working beneath the vehicle. Use additional safety supports beneath the vehicle.

Do not leave tools, lifting equipment, spilt oil, etc. around or on the work bench area.

**Precautions against damage**

Always fit wing and seat covers before commencing work. Avoid spilling brake fluid or battery acid on paintwork. Wash off with water immediately if this occurs.

Disconnect the battery earth lead before starting work. See **ELECTRICAL PRECAUTIONS**.

Always use the recommended service tool or a satisfactory equivalent where specified.

Protect exposed bearing and sealing surfaces and screw threads from damage.

**Brake Hydraulics**

**WARNING: It is imperative that the correct brake fittings are used and that threads of components are compatible.**

Always use two spanners when slackening or tightening brake pipe or hose connections. Ensure that hoses run in a natural curve and are not kinked or twisted. Fit brake pipes securely in their retaining clips and ensure that the pipe run cannot contact a potential chafing point.

Containers used for hydraulic fluid must be kept absolutely clean. Do not store hydraulic fluid in an unsealed container; it will absorb water and in this condition will be dangerous to use. Do not allow hydraulic fluid to be contaminated with mineral oil, or use a container which has previously contained mineral oil. Do not re-use fluid from the system. Always use clean brake fluid or a recommended alternative to clean hydraulic components. Fit a blanking cap to an hydraulic union and a plug to its socket after removal to prevent the ingress of dirt. Absolute cleanliness must be observed with hydraulic components.

**Engine coolant caps and plugs**

Extreme care is necessary when removing engine coolant caps and plugs when the engine is hot and especially if it is overheated. To avoid the possibility of scalding allow the engine to cool before attempting coolant cap or plug removal.

**Cleaning components**

Always use the recommended cleaning agent or equivalent.

Do not use degreasing equipment for components containing items which could be damaged by the use of its process. Whenever possible clean components and the area surrounding them before removal. Always observe scrupulous cleanliness when cleaning dismantled components.

## FUEL HANDLING PRECAUTIONS

The following information provides basic precautions which must be observed if fuel is to be handled safely. It also outlines the other areas of risk which must not be ignored.

This information is issued for basic guidance only, and in any case of doubt, appropriate enquiries should be made of your local Fire Officer or Fire Department.

Fuel vapor is highly flammable and in confined spaces is also very explosive and toxic.

When fuel evaporates it produces 150 times its own volume in vapor, which when diluted with air becomes a readily ignitable mixture. The vapor is heavier than air and will always fall to the lowest level. It can readily be distributed throughout a workshop by air current, consequently, even a small spillage of fuel is very dangerous.

Always have a fire extinguisher containing **FOAM CO<sup>2</sup> GAS**, or **POWDER** close at hand when handling fuel, or when dismantling fuel systems and in areas where fuel containers are stored.



**WARNING: It is imperative that the battery is not disconnected during fuel system repairs as arcing at the battery terminal could ignite fuel vapour in the atmosphere. Always disconnect the vehicle battery BEFORE carrying out work on the fuel system.**

**Whenever fuel is being handled, transferred or stored, or when fuel systems are being dismantled all forms of ignition must be extinguished or removed, any leadlamps used must be flame proof and kept clear of spillage.**

**No one should be permitted to repair components associated with fuel without first having had fuel system training.**

## Hot fuel handling precautions



**WARNING: Before commencing any operation requiring fuel to be drained from the fuel tank, the following procedure must be adhered to:**

1. Allow sufficient time for the fuel to cool, thus avoiding contact with hot fuels.
2. Vent the system by removing the fuel filler cap in a well ventilated area. Refit the filler cap until the commencement of fuel drainage.

## Fuel transfer



**WARNING: Fuel must not be extracted or drained from any vehicle while it is standing over a pit.**

The transfer of fuel from the vehicle fuel tank must be carried out in a well ventilated area. An approved transfer tank must be used according to the transfer tank manufacturer's instructions and local regulations, including attention to grounding of tanks.

## Fuel tank removal

A **FUEL VAPOUR** warning label must be attached to the fuel tank upon removal from the vehicle.

## Fuel tank repair

Under no circumstances should a repair to any tank be attempted.

## ELECTRICAL PRECAUTIONS

### General

The following guidelines are intended to ensure the safety of the operator whilst preventing damage to the electrical and electronic components fitted to the vehicle. Where necessary specific precautions are detailed in the relevant sections of this Manual which should be referred to prior to commencing repair operations.

Equipment - Prior to commencing any test procedure on the vehicle ensure that the relevant test equipment is working correctly and any harness or connectors are in good condition. This particularly applies to mains lead and plugs.



**WARNING: Before commencing work on an ignition system all high tension terminals, adaptors and diagnostic equipment for testing should be inspected to ensure that they are adequately insulated and shielded to prevent accidental personal contacts and minimise the risk of shock. Wearers of surgically implanted pacemaker devices should not be in close proximity to ignition circuits or diagnostic equipment.**

Polarity - Never reverse connect the vehicle battery and always observe the correct polarity when connecting test equipment.

High Voltage Circuits - Whenever disconnecting live ht circuits always use insulated pliers and never allow the open end of the ht lead to come into contact with other components, particularly ECU's. Exercise caution when measuring the voltage on the coil terminals while the engine is running, as high voltage spikes can occur on these terminals.

Connectors and Harness - The engine compartment of a vehicle is a particularly hostile environment for electrical components and connectors. Always ensure these items are dry and oil free before disconnecting and connecting test equipment. Never force connectors apart either by using tools or by pulling on the wiring harness. Always ensure locking tabs are disengaged before removal and not orientation to enable correct reconnection. Ensure that any protective covers and substances are replaced if disturbed.

Having confirmed a component to be faulty, switch off the ignition and disconnect the battery. Remove the component and support the disconnected harness. When replacing the component keep oily hands away from electrical connection areas and push connectors home until any locking tabs fully engage.

### Battery disconnecting

Before disconnecting the battery, switch off all electrical equipment. If the radio is to be serviced, ensure the security code has been deactivated.



**CAUTION: To prevent damage to electrical components ALWAYS disconnect the battery when working on the vehicle electrical system. The earth lead must be disconnected first and reconnected last. Always ensure that battery leads are routed correctly and are not close to any potential chafing points.**

### Battery charging

Recharge the battery out of the vehicle and keep the top well ventilated. While being charged or discharged, and for approximately fifteen minutes afterwards, batteries emit hydrogen gas. This gas is inflammable.

Always ensure any battery charging is well ventilated and that every precaution is taken to avoid naked flames and sparks.

### Jump starting

**! WARNING:** Hydrogen and oxygen gases are produced during normal battery operation. This gas mixture can explode if flames, sparks or lighted tobacco are brought near battery. When charging or using a battery in an enclosed space, always provide ventilation and shield your eyes.

Keep out of reach of children. Batteries contain sulphuric acid. Avoid contact with skin, eyes, or clothing. Also, shield eyes when working near battery to protect against possible splashing of acid solution. In case of acid contact with skin, eyes, or clothing, flush immediately with water for a minimum of fifteen minutes. If acid is swallowed, drink large quantities of milk or water, followed by milk of magnesia, a beaten egg, or vegetable oil. **SEEK MEDICAL AID IMMEDIATELY.**

#### To Jump Start - Negative Ground Battery

**! WARNING:** To avoid any possibility of injury use particular care when connecting a booster battery to a discharged battery.

1. Position vehicles so that jump leads will reach, ensuring that vehicles **DO NOT TOUCH**, alternatively a fully charged slave battery may be positioned on floor adjacent to vehicle.
2. Ensuring that ignition and all electrical accessories are switched off, that parking brake is applied and neutral is selected on a manual gearbox, with an automatic gearbox select neutral (N) or park (P) and then connect the jump leads as follows;

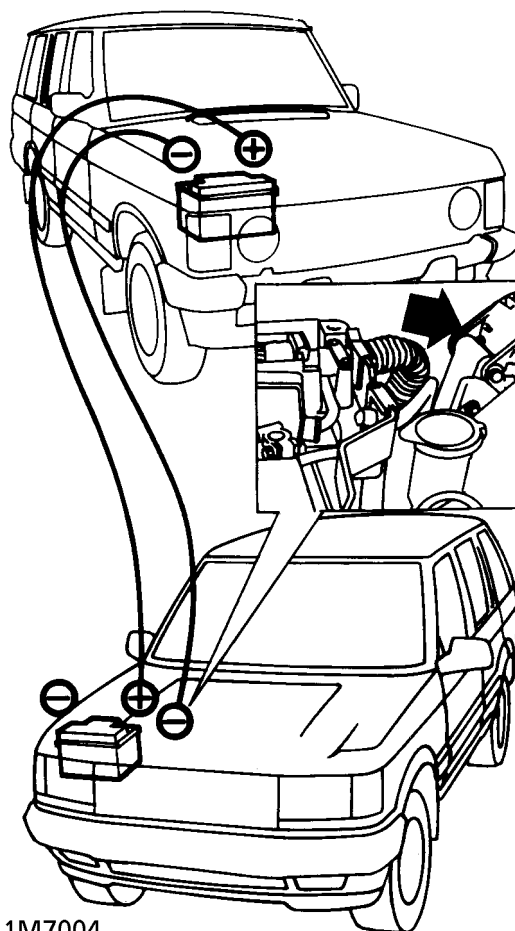

1M7004

- A. Connect one end of first jumper cable to positive (+) terminal of booster battery.
- B. Connect other end of first jumper cable to positive (+) terminal of discharged battery.
- C. Connect one end of second jumper cable to negative terminal of booster battery.
- D. Connect other end of second jumper cable to a good earth point on the engine, **NOT TO NEGATIVE TERMINAL OF DISCHARGED BATTERY**. Keep jumper lead away from moving parts, pulleys, drive belts and fan blade assembly.

**! WARNING:** Making final cable connection could cause an electrical arc which if made near battery could cause an explosion.

3. If booster battery is installed in another vehicle, start engine and allow to idle.
4. Start engine of vehicle with discharged battery, following starting procedure in Owners' Manual.



**CAUTION: If vehicle fails to start within a maximum time of 12 seconds, switch ignition off and investigate cause. Failing to follow this instruction could result in irreparable damage to catalysts.**

5. Remove negative (-) jumper cable from the engine and then terminal of booster battery.
6. Remove positive (+) jumper cable from positive terminals of booster battery and discharged battery.

### Disciplines

Switch off ignition prior to making any connection or disconnection in the system as electrical surge caused by disconnecting 'live' connections can damage electrical components.

Ensure hands and work surfaces are clean and free of grease, swarf, etc. as grease collects dirt which can cause tracking or high-resistance contacts.

When handling printed circuit boards, treat them as you would a disc - hold by the edges only; note that some electronic components are susceptible to body static.

Connectors should never be subjected to forced removal or refit, especially inter-board connectors, as damaged contacts will cause short circuit and open-circuit conditions.

Prior to commencing test, and periodically during test, touch a good earth (i.e. cigar lighter socket) to discharge body static as some electronic components are vulnerable to static electricity.

### Grease for electrical connectors

All underbonnet and underbonnet connectors are protected against corrosion by the application of a special grease on production. Should connectors be disturbed in service, repaired or replaced, a grease of this type (available in 150gm tubes under Part No. BAU 5811) should again be applied.



**NOTE: The use of other greases must be avoided as they can migrate into relays, switches etc., contaminating the contacts and leading to intermittent operation or failure.**

---

## BODY REPAIRS

---

Body shells are of welded construction and bolted to the chassis frame. Front and rear sections of the shell are designed as 'energy absorbing' zones. This means they are designed to deform progressively when subjected to impact in order to minimise the likelihood of injury to vehicle occupants.

It is essential that design dimensions and strength are restored in accident rectification. It is important that neither structural weakness nor excessive local stiffness are introduced into the vehicle during body or chassis repair.

Repairs usually involve a combination of operations ranging from straightening procedures to renewal of either individual panels or panel assemblies. The repairer will determine the repair method and this decision will take into account a balance of economics between labour and material costs and the availability of repair facilities in both equipment and skills. It may also involve considerations of vehicles down-time, replacement vehicle availability and repair turn-around time.

It is expected that a repairer will select the best and most economic repair method possible, making use of the facilities available. The instructions given are intended to assist a skilled body repairer by expanding approved procedures for panel replacement with the objective of restoring the vehicle to a safe running condition and effecting a repair which is visually acceptable and which, even to the experienced eye, does not advertise the fact that it has been damaged.

This does not necessarily mean that the repaired vehicle will be identical in all respects with original factory build. Repair facilities cannot always duplicate methods of construction used during production.

Operations covered in this Manual do not include reference to testing the vehicle after repair. It is essential that work is inspected and suspension geometry checked after completion and if necessary a road test of the vehicle is carried out, particularly where safety related items are concerned.

Where major units have been disconnected or removed, it is necessary to ensure that fluid levels are checked and topped up when necessary. It is also necessary to ensure that the repaired vehicle is in a roadworthy condition in respect of tyre pressures, lights, washer fluid etc.

Body repairs often involve the removal of mechanical and electrical units as well as associated wiring. **See BODY and SRS sections.**

Taking into consideration the differences in body styles, steering and suspension systems as well as engine and suspension layouts, the location of the following components as applicable to a particular vehicle is critical:

- Front suspension upper damper mountings.
- Front suspension or sub frame mountings.
- Engine mounting on RH and LH chassis longitudinals.
- Rear suspension upper damper mountings.
- Rear suspension mountings or lower pivots.
- Steering rack mountings.

Additional points which can be used to check alignment and assembly are:

- Inner holes in crossmember - side - main floor.
- Holes in front longitudinals.
- Holes in extension - side member - front.
- Holes in rear longitudinals.
- Holes in rear lower panels or extension rear floor.
- Fuel tank mountings.

Apertures for windscreen, backlight, bonnet and doors can best be checked by offering up an undamaged component as a gauge.



## JACKING

The following instructions must be carried out before raising the vehicle off the ground.

1. Use a solid level ground surface.
2. Apply parking brake.
3. Select 'P' or 1st gear in main gearbox.
4. Select Low range in transfer gearbox.



**CAUTION:** To avoid damage occurring to the under body components of the vehicle the following jacking procedures must be adhered to.

**DO NOT POSITION JACKS OR AXLE STANDS UNDER THE FOLLOWING COMPONENTS.**

Body structure	Air suspension pipes
Bumpers	Fuel lines
Brake lines	Front radius arms
Panhard rod	Steering linkage
Rear Trailing links	Fuel tank
Engine sump	Gearbox bell housing



**CAUTION:** If supporting vehicle by the front crossmember, the safety stands must be positioned carefully to avoid damage to air suspension pipes.

## Vehicle jack

The jack provided with the vehicle is only intended to be used in an emergency, for changing a tyre. Do **NOT** use the jack for any other purpose. Refer to Owner's Manual for vehicle jack location points and procedure. Never work under a vehicle supported by the vehicle jack.

## Hydraulic jack

A hydraulic jack with a minimum 1500 kg, 3,300 lbs load capacity must be used.



**CAUTION:** Do not commence work on the underside of the vehicle until suitable axle stands have been positioned under the axle.

axle.

## Raise the front of the vehicle

1. Position cup of hydraulic arm under differential casing.



**NOTE:** The differential casing is not central to the axle. Care should be taken when raising the front road wheels off the ground as the rear axle has less sway stiffness.



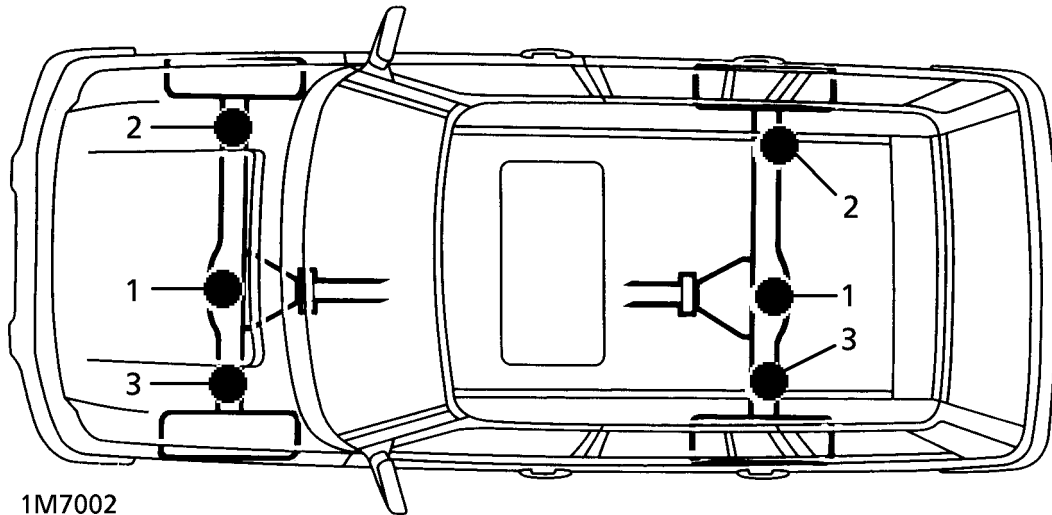

2. Raise front road wheels to enable an axle stand to be installed under left hand axle tube.
  3. Position an axle stand under right hand axle tube, carefully lower jack until axle sits securely on both axle stands, remove trolley jack.
  4. Before commencing work on underside of vehicle re-check security of vehicle on stands.
  5. Reverse procedure when removing vehicle from stands.
3. Lower jack until axle sits securely on axle stands, remove trolley jack.
  4. Before commencing work on underside of vehicle re-check security of vehicle on stands.
  5. Reverse procedure when removing vehicle from stands.

#### Raise rear of vehicle

1. Position cup of hydraulic arm under differential casing.
2. Raise vehicle to enable axle stands to be installed under left and right hand axle tubes.

---

**HYDRAULIC VEHICLE RAMP (FOUR POST)**

---

Use only a 'drive on' type ramp which supports vehicle by its own road wheels. If a 'wheel-free' condition is required, use a 'drive on' ramp incorporating a 'wheel-free' system that supports under axle casings. Alternatively, place vehicle on a firm, flat floor and support on axle stands.

---

**TWO POST VEHICLE RAMPS**

---

The manufacturer of RANGE ROVER VEHICLES DOES NOT recommend using 'Two Post' ramps that employ four adjustable support arms. These are NOT considered safe for Range Rover vehicles.

If vehicle is installed on a Two Post ramp responsibility for safety of vehicle and personnel performing service operations is in the hands of the Service Provider.

---

**DYNAMOMETER TESTING - VEHICLES WITH ANTI-LOCK BRAKES (ABS)**

---



**WARNING: Do not attempt to test ABS function on a dynamometer**

**Four wheel dynamometers**

**NOTE: Before testing a vehicle on a four wheel dynamometer disconnect the valve relay. See *Electrical Trouble Shooting Manual*.**

The ABS function will not work, the ABS warning light will illuminate. Normal braking will be available.

Provided that front and rear rollers are rotating at identical speeds and that normal workshop safety standards are applied, there is no speed restriction during testing except any that may apply to the tyres.

**Two wheel dynamometers**

**IMPORTANT: Use a four wheel dynamometer for brake testing if possible.**



**NOTE: ABS will not function on a two wheel dynamometer. The ABS light will illuminate during testing. Normal braking will be available.**

If brake testing on a single rig is necessary it must be carried out with propeller shaft to the rear axle removed, AND neutral selected in BOTH main and transfer boxes.

If checking engine performance, the transfer box must be in high range and drive shaft to stationary axle removed.

## EMERGENCY TOWING



**CAUTION:** The New Range Rover has permanent four-wheel drive. The following instructions must be adhered to when towing:-

towing:-

## Towing the vehicle on four wheels

If it is necessary to recover the vehicle by towing on all four wheels, 'Transfer neutral' **MUST** be selected.

1. With the starter key removed, insert a fuse of 5 amps or more in fuse position '11' in the RH seat fuse box.
2. Turn the starter switch to position '2'; the transfer box will now automatically select neutral.
3. Wait until the message centre displays 'TRANSFER NEUTRAL' and then turn the starter switch off, position '0'.
4. Turn the starter switch to position '1' to unlock the steering and leave in this position while the vehicle is being towed.

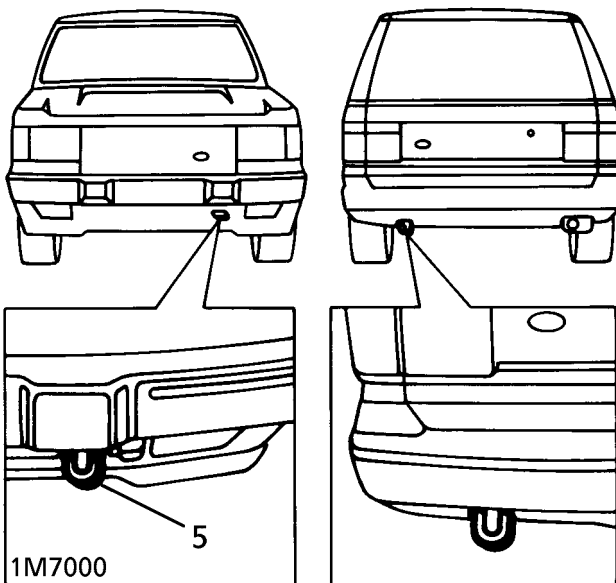

5. Secure tow rope to the front towing eye.
6. Release the parking brake.



**CAUTION:** The brake servo and power assisted steering system will not be functional without the engine running. Heavier pedal pressure will be required to apply the brakes, the steering system will require greater effort to turn the front wheels. The vehicle tow connection should be used only in normal road conditions.



**CAUTION: DO NOT** remove the starter key or turn the switch to position '0' when the vehicle is in motion.

7. To reactivate the transfer box after towing, turn the starter switch off to position '0' and remove the fuse from position '11'. On automatic vehicles the transfer box will automatically engage the Low or High gear range.
8. On manual vehicles, first press the range change switch. The transfer box will then engage the Low or High gear range.

## Suspended tow by breakdown vehicle



**CAUTION:** To prevent vehicle damage, front or rear propeller shaft **MUST** be removed, dependant upon which axle is being trailed.

9. To facilitate reassembly, first mark the propeller shaft drive flanges at transfer box and axle.
10. Remove propeller shaft fixings and lift shaft from vehicle.
11. If the front axle is to be trailed turn ignition key to position '1' to release the steering lock.



**CAUTION:** If the rear axle is to be raised, the steering wheel and/or linkage **MUST** be secured in a straight ahead position. **DO NOT** use the steering lock for this purpose.

## TRANSPORTING THE VEHICLE BY TRAILER

If the vehicle should require transporting on a trailer or the back of a lorry, the air suspension must be set to 'ACCESS' before being lashed. **See FRONT SUSPENSION, Description and operation.**

Lashing eyes are provided on the front and rear chassis cross members to facilitate the securing of the vehicle, as shown.

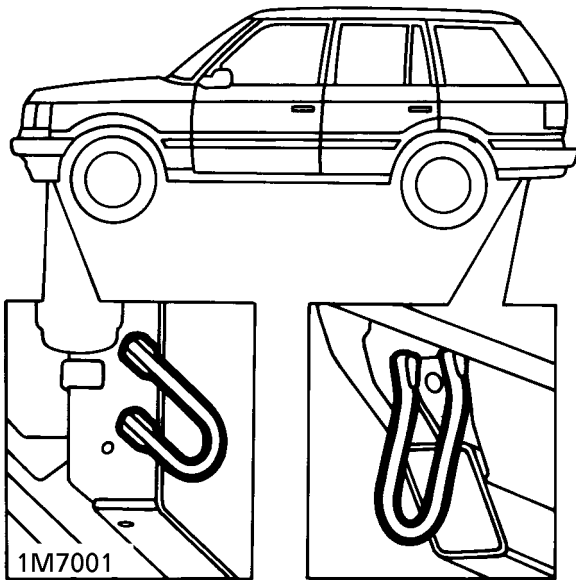

**CAUTION: DO NOT** secure lashing hooks or trailer fixings to any other part of the vehicle.



**CAUTION: If the air suspension cannot be set to the 'ACCESS' position, then the vehicle must be lashed by its wheels and not the lashing eyes.**

Install vehicle on the trailer and apply park brake. Select neutral in main gearbox; this will prevent damage to the parking pawl of the automatic gearbox.

**VEHICLE DIMENSIONS**

	<b>mm</b>	<b>inches</b>
Overall length .....	4713	185.6
with Europe/UK towbar .....	4804	189.1
Overall width .....	1889	74.4
Overall height at standard profile .....	1817.5	71.6
Wheelbase .....	2745	108.1
Track:		
Front .....	1540	60.6
Rear .....	1530	60.2
Turning circle between kerbs .....	1189 mm (39 ft)	

**STEERING****Power steering box**

Make/type .....	ZF type 8055, recirculating ball steering gear
Steering wheel turns, lock-to-lock .....	3.2

**Steering pump**

Make/type:	
V8 engine .....	ZF type 7691, vane type
Diesel engine .....	ZF type 7681, vane type

**Steering geometry**

Steering wheel diameter .....	406.4mm (16 in.)	
Toe-out measurement .....	0.6 to 1.80mm (0.02 - 0.07 in.)	
Toe-out included angle .....	0° 5' to 0° 15'	
Camber angle .....	0°	<b>NOTE:</b> <b>Check at</b> <b>kerbweight</b>
Castor angle .....	4°	
Swivel pin inclination static .....	8°	



## VEHICLE WEIGHTS AND PAYLOAD

When loading a vehicle to its maximum (Gross Vehicle Weight), consideration must be taken of the vehicle kerb weight and the distribution of the payload to ensure that axle loadings do not exceed the permitted maximum values. It is the customer's responsibility to limit the vehicle's payload in an appropriate manner such that neither maximum axle loads nor Gross Vehicle Weight are exceeded.

### GROSS VEHICLE WEIGHT

	Petrol Models	Diesel Models
Front Axle .....	1320 kg (2910 lb) .....	1320 kg (2910 lb)
Rear Axle .....	1840 kg (4056 lb) .....	1840 kg (4056 lb)
Total .....	2780 kg (6129 lb) .....	2780 kg (6129 lb)
Maximum Payload .....	603 kg (1329 lb) .....	596 kg (1314 lb)

### EEC KERB WEIGHT AND DISTRIBUTION

	4.0 Litre Manual	4.0 Litre Automatic	4.6 Litre Automatic
EEC Kerb Weight .....	2090 kg (4607 lb) .....	2100 kg (4629 lb) .....	2220 kg (4894 lb)
Front Axle .....	1095 kg (2414 lb) .....	1100 kg (2425 lb) .....	1165 kg (2568 lb)
Rear Axle .....	995 kg (2193 lb) .....	1000 kg (2204 lb) .....	1055 kg (2325 lb)

	2.5 Diesel Manual	2.5 Diesel Automatic
EEC Kerb Weight .....	2115 kg (4662 lb) .....	2130 kg (4695 lb)
Front Axle .....	1110 kg (2447 lb) .....	1120 kg (2469 lb)
Rear Axle .....	1005 kg (2215 lb) .....	1010 kg (2226 lb)



**NOTE:** EEC KERB WEIGHT is the minimum vehicle specification plus full fuel tank and 75 kg (165lb) driver.



**NOTE:** GROSS VEHICLE WEIGHT is the maximum all-up weight of the vehicle including driver, passengers, and equipment. This figure is liable to vary according to legal requirements in certain countries.



**NOTE:** MAXIMUM ROOF RACK LOAD (including weight of rack) 75 kg (165 lb) must be included in total vehicle weight.

ALIGNMENT JIG DIMENSIONS

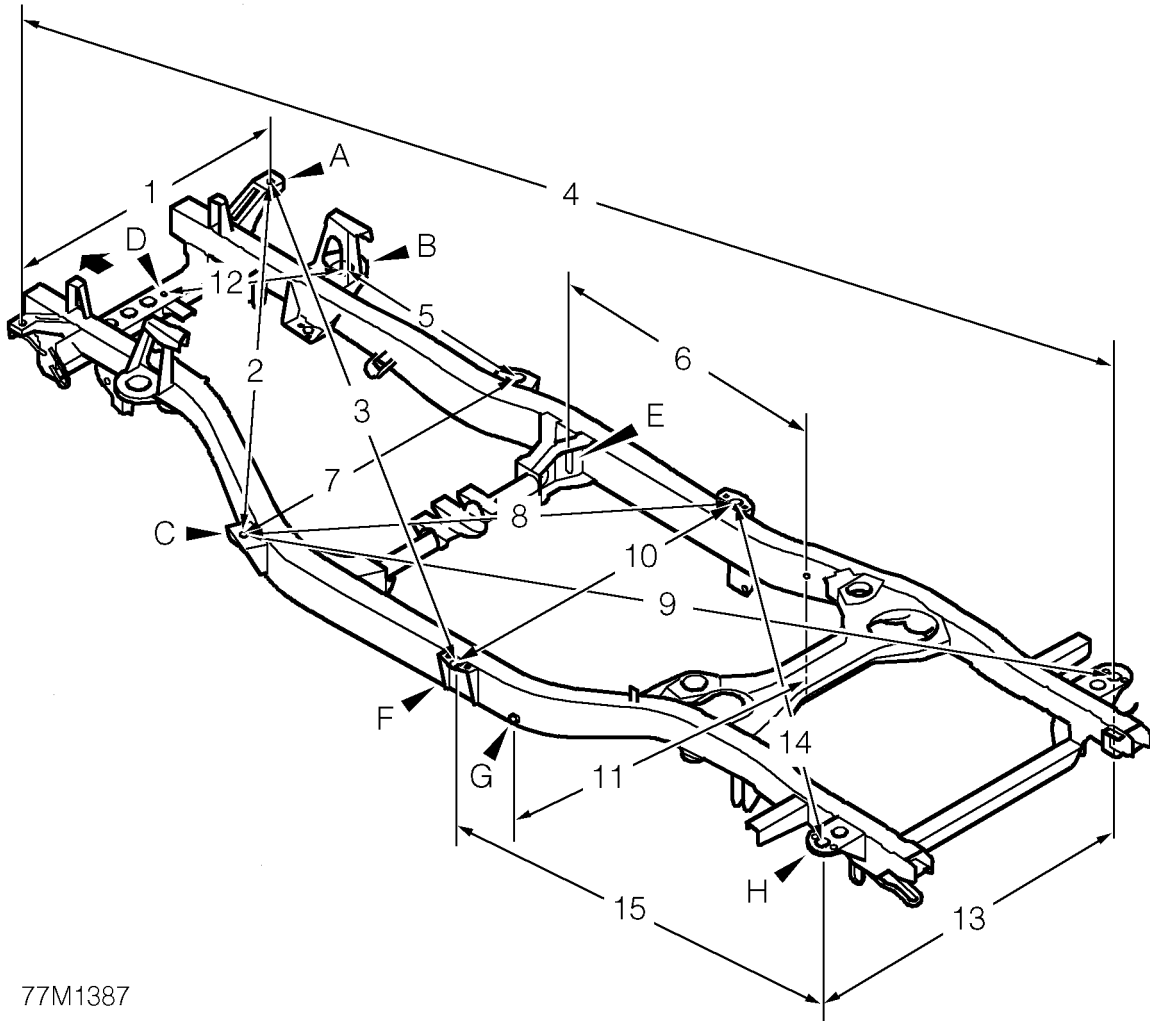

77M1387

- 1. 1190mm (46.8in.)
- 2. 1709mm (67.3in.)
- 3. 2527mm (99.6in.)
- 4. 4173mm (164.4in.)
- 5. 717mm (28.3in.)
- 6. 982.5mm (38.7in.)
- 7. 1328mm (52.3in.)
- 8. 1697mm (66.9in.)
- 9. 3159mm (124.5in.)
- 10. 1340mm (52.8in.)
- 11. 1302mm (51.3in.)
- 12. 665mm (26.2in.)

- 13. 1400mm (55.2in.)
- 14. 2364mm (93.1in.)
- 15. 1803mm (71.0in.)

- A = No. 1 body mount RH and LH
- B = Front spring seat RH and LH
- C = No. 2 body mount RH and LH
- D = Front crossmember piercing RH and LH
- E = Front radius arm mounting bracket RH and LH
- F = No. 3 body mount RH and LH
- G = Rear composite link mounting bracket RH and LH
- H = No. 5 body mount RH and LH

All dimensions taken at centre line of set screw or set screw hole.

### **Straightening**

Whenever possible, structural members should be cold straightened under tension. Do not attempt to straighten with a single pull, but rework the damaged area using a series of pulls, releasing tension between each stage and using the opportunity to check alignment.

### **Body jig**

Unless damage is limited to cosmetic panels, all repair work to body members must be carried out on a body jig, to ensure that impact damage has not spread into more remote parts of the body structure. Mounting on a jig will also ensure that the straightening and panel replacement procedures do not cause further distortion. If original dimensions cannot be satisfactorily restored by these methods, damaged structural members should be replaced. Damaged areas should be cut away using a high speed saw, NOT an oxy-acetylene torch.

As a rule, body dimensions are symmetrical about the centre line. A good initial check for distortion is therefore to measure diagonally and to investigate apparent differences in dimensions.

### **Inspection**

Every accident produces individual differences in damage. Each repair is influenced by the extent of the damage and by the facilities and equipment available for its rectification.

Most accident damage can be visually inspected and the approximate extent of the damage assessed. Sometimes deformation will extend beyond the area of direct damage, and the severity of this must be accurately established so that steps may be taken to restore critical body components to their original dimensions.

An initial check of critical dimensions can be carried out by means of drop checks or (preferably) trammels. Gauges are available which will check accurately for body twist. Where repairs necessitate renewal of a critical body component it is recommended that a body jig is used.



---

**ELECTRONIC CONTROL UNITS**

---

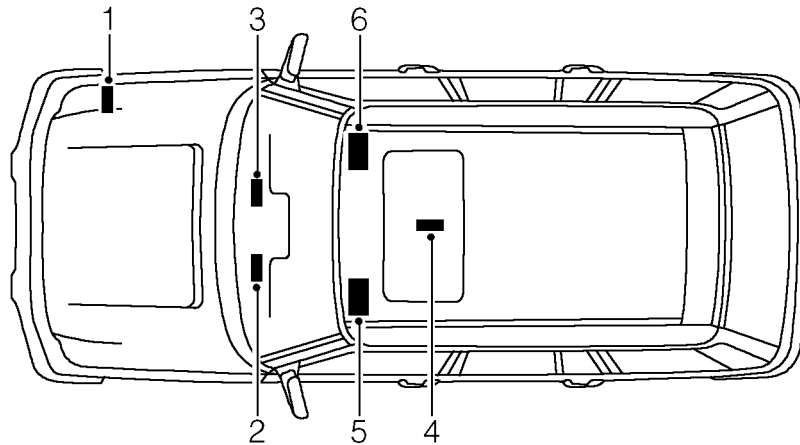

77M1382

- |  |  |
|--|--|
| 1. Engine control module (ECM) (at RH of engine bay) | 4. Diagnostic control unit (on centre tunnel)                    |
| 2. ABS ECU (behind access plate at LH of dashboard)  | 5. Electronic suspension ECU (beneath LH front seat)             |
| 3. Cruise control ECU (behind fascia closing panel)  | 6. Body electrical control module (BeCM) (beneath RH front seat) |

The electronic control units fitted to Land Rover vehicles make it advisable to follow suitable precautions prior to carrying out welding repair operations. Harsh conditions of heat and vibration may be generated during these operations which could cause damage to the units. **See ELECTRICAL PRECAUTIONS section.**

In particular, it is essential to follow the appropriate precautions when disconnecting or removing the SRS diagnostic unit. **See SUPPLEMENTARY RESTRAINT SYSTEM, Precautions section.**



**APPROVED MATERIALS**

MATERIAL	MANUFACTURER
SEALERS	<p>3M:                      Bodygard (08158, 08159)                      Weld Thru' Sealer (08625)                      Drip-Chek Clear (08401)                      Drip-Chek Heavy (08531)                      Flexseal Polyurethane Seam Sealer (08684, 08689, 08694)                      Polyurethane Sealer (sachet) (08703, 08783, 08788)                      Super Seam Sealer (08537)                      Sprayable Sealer (08800, 08823)                      Bolted Panel Sealer (08572)                      Body Caulking (08568)                      Windscreen Sealer (08509)</p> <p>Gurit-Essex:                      Betafill Clinch and Brushable Sealer (Black) (10215)                      Betafill Clinch and Brushable Sealer (Grey) (10211)                      Betafill Clinch and Brushable Sealer (White) (10220)                      Clinch Joint and Underbody Coating (Grey) (10101)                      Clinch Joint and Underbody Coating (Beige) (10707)</p> <p>Kent Industries:                      Leak-Chek Clear Putty (10075)</p> <p>PPG:                      Polyurethane Seam Sealer (6500)                      Polyurethane Seam Sealer (92)                      Terostat Preformed Strip (V11)                      Terolan Light Seam Sealer</p> <p>Teroson:                      Terolan Special Brushable Seam Sealer                      Terostat 1K PU Seam Sealer (SE20)                      Terostat Sprayable Seam Sealer (9320)</p> <p>Unipart:                      Promatch Sealing Compound (UBS605, UBS606, UBS607)                      Promatch Bolted Panel Sealer (UBS111)</p> <p>Würth:                      Sealing Compound (890100, 890101, 890102, 890103, 890104, 890105, 890106)                      Astrolan Engine Bay Wax &amp; Cosmetic Wax (DA3241/DA3243)                      Weld Thru' Coating (05913)</p>

## Approved materials (continued)

MATERIAL	MANUFACTURER
ADHESIVES	3M: Automotive Structural Adhesive (08120) Aerosol Auto Adhesive (Trim) (08080) Spray 80 Adhesive (08090) Ciba-Geigy: Structural Two-Part Epoxy (XB5106/XB5107)
UNDERBODY COATINGS	3M: Spray Schutz (08877) Body Schutz (08861) Stone Chip Coating (Textured) (08868, 08878, 08879) Stone Chip Coating (Smooth) (08158, 08160, 08886) Croda: Crodapol Brushable Underbody Sealer (PV75) Underbody Wax (PW61) Dinol: Tectacote Underbody Wax (205) Teroson: Terotex Underseal CP02 (9320) Unipart: Promatch Underbody Schutz (UBS410) Promatch Underbody Wax (PW61)
WAX COATINGS	3M: Inner Cavity Wax (Transparent) (08909, 08919, 08929) Inner Cavity Wax (Amber) (08901, 08911, 08921) Dinol: Engine Bay & Cosmetic Wax/Lacquer (PW197) Cavity Wax (PW57) Engine Bay Cosmetic Wax/Lacquer (4010) Unipart: Promatch Cavity Wax (UBS508)



## Approved materials (continued)

MATERIAL	MANUFACTURER
WELD-THROUGH PRIMERS	3M: Zinc Spray (09113) ICI: Zinc Rich Primer (P-565 634)
GENERAL MATERIALS	3M: Flexible Parts Repair Material (05900) Cleaner and Wax Remover (1 litre) (08984) Waterproof Cloth Tape (Y387/YS3998) Teroson: Sprayable Aerosol, Water Shedder Repair Unipart: Waterproof Tape (GWS121) Urethane Butyl Tape (BHM605)

---

**MATERIALS APPLICATIONS**

---

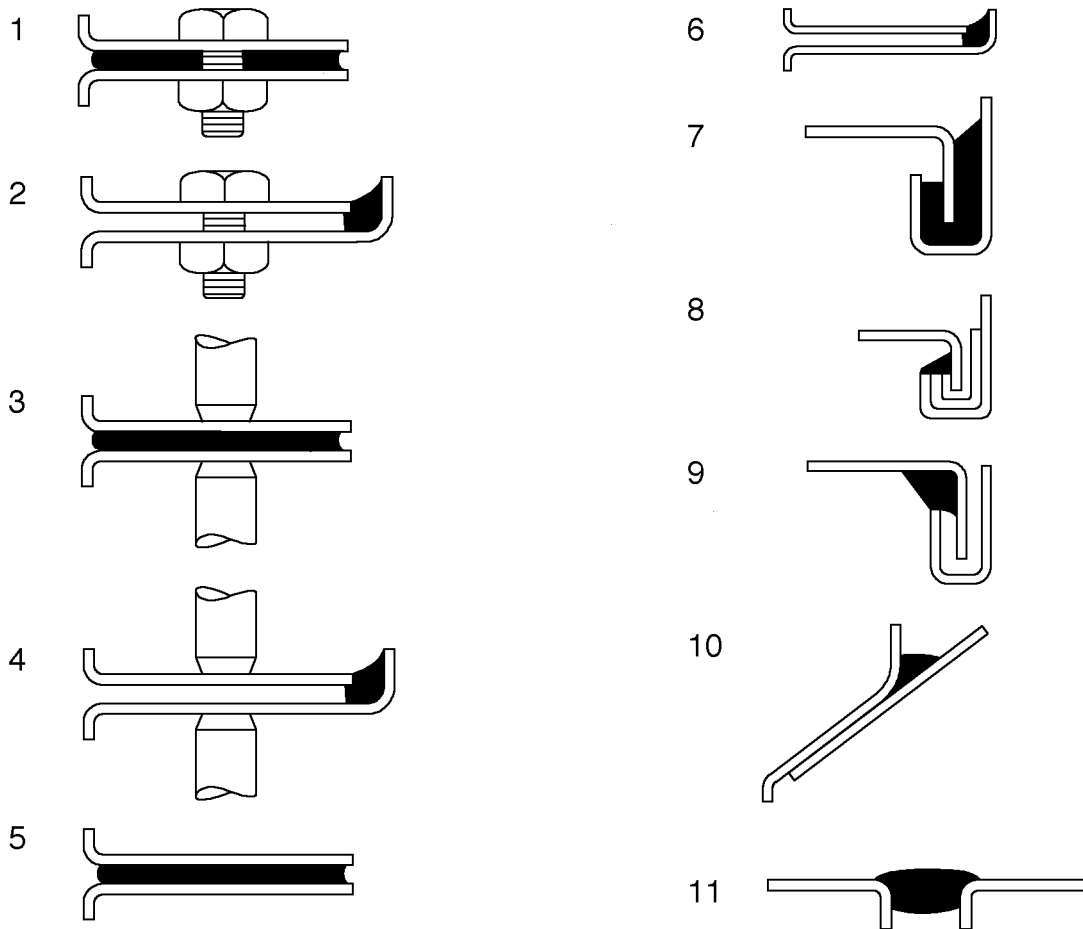
**Joint Types:**

77M1356

- |                                    |                                  |
|------------------------------------|----------------------------------|
| 1. Between bolted panels           | 7. Clinch joints (type a)        |
| 2. Between bolted panel edges      | 8. Clinch joints (type b)        |
| 3. Between spot welded panels      | 9. Clinch joints (type c)        |
| 4. Between spot welded panel edges | 10. Gaps between panels (type a) |
| 5. Between bonded panels           | 11. Gaps between panels (type b) |
| 6. Between bonded panel edges      |                                  |

## Materials applications (continued)

MANUFACTURER	MATERIAL/JOINT TYPE
ICI P565 634 3M 09113	Zinc rich primer. Between bolted and spot welded panels, clinch joints (type a). Brush or spray application.
Teroson Terostat V11	Preformed strip. Between bolted panels. Hand application.
Kent Industries 10075 3M 08401 3M 08572 3M 08684 3M 08689 3M 08694 3M 08703 3M 08783 3M 08788 PPG Polyurethane 6500 Teroson 92 Terolan Light Terostat 1K PU Terostat 9320 Unipart UBS 605/6/7 Würth 890100/1/2/3/4/5/6	Seam sealer. Between bolted panel edges. Applicator gun/by hand.
Ciba-Geigy XBS106/7 3M 08120	Structural adhesive. Between spot welded and bonded panels, clinch joints (type a). Applicator gun, caulking gun.
3M 08625	Seam sealer. Between spot welded panels. Applicator gun.
Kent Industries 10075 3M 08401 3M 08684 PPG 6500 Teroson 92 Terolan Light Terostat 9320 Terostat 1K PU Unipart UBS605/6/7 Würth 890100/1/2/3/4/5/6	Seam sealer light. Between spot welded panel edges. Hand applicator gun.

## Materials applications (continued)

MANUFACTURER	MATERIAL/JOINT TYPE
Ciba-Geigy XBS106/7 3M 08120	Structural adhesive. Between bonded panels. Caulking gun.
PPG 6500 Teroson 92 Terostat 9320 Unipart UBS605/6/7 Würth 890100/1/2/3/4/5/6	Semi-structural adhesive/anti-flutter material. Between bonded panels. Caulking gun.
Kent Industries 10075 3M 08401 3M 08694 PPG 6500 Teroson 92 Teroson Light Teroson 9320 Terostat 1K PU Unipart UBS605/6/7 Würth 890100/1/2/3/4/5/6	Seam sealer light. Between bonded panel edges. Hand applicator gun.
Gurit-Essex 10211 Gurit-Essex 10215 Gurit-Essex 10220 3M 08531 3M 08537 3M 08703 3M 08783 3M 08788	Seam sealer. Clinch joints (type b). Caulking gun.

## Materials applications (continued)

MANUFACTURER	MATERIAL/JOINT TYPE
Kent Industries 10075 3M 08401 3M 08531 Teroson Terolan Light	Seam sealer light. Clinch joints (type c). Caulking gun, hand applicator gun.
Kent Industries 10075 3M 08401 3M 08684 3M 08689 3M 08694 PPG 6500 Teroson 92 Terolan Light Terostat 1K PU Unipart UBS605/6/7 Wurth 890100/1/2/3/4/5/6	Seam sealer light. Gaps between panels (type a). Hand applicator gun.
Kent Industries 10075 Kent Industries Putty 3M 08401 3M 08531 3M 08568 3M 08684 3M 08689 3M 08694 PPG 6500 Teroson 92 Terolan Light Terostat 9320 Terostat 1K PU Unipart UBS605/6/7 Wurth 890100/1/2/3/4/5/6 Gurit-Essex 10101 Gurit-Essex 10707 3M 08537	Seam sealer heavy. Gaps between panels (type b). Hand applicator gun, applicator tube or caulking gun.
Gurit-Essex 10211 Gurit-Essex 10215 Gurit-Essex 10220 Teroson Brushable Sealer	Brushable sealer. Overlap joints (e.g. floor pans). Brush.
Croda PW57 3M Cavity Waxes Unipart UBS508	Cavity wax. Box members, sills. Injection equipment.



## Materials applications (continued)

MANUFACTURER	MATERIAL/JOINT TYPE
Croda PV75 3M 08861 3M 08877 Teroson Terotex Underseal Unipart UBS410	Underbody sealing coat. Underbody. Schutz gun, aerosol.
Croda PW61 Dinol 205 Unipart PW61	Underbody wax coat. Underbody. Spray gun or brush.
Astors 3241/3 Croda PW197 Dinol 4010	Engine bay cosmetic wax/lacquer. Spray gun or brush.
3M Stone Chip Coatings	Anti-chip coating. Sill panels. Schutz gun.
3M 05900 Plastic Parts Repair Material	Two-pack material. Repair of plastic parts. Spreader or palette knife.
3M 08509	Dry glazed windscreen sealer. Applicator gun.
Unipart BHM605	Urethane butyl sealer for direct glazing. Caulking gun.
3M YS3998 3M Y387 Unipart GS121	Waterproof tape for sealing apertures. Hand application.
Evode Evo-Stik 3M 08030 3M 08034 3M 08080 3M 08090	Trim fixing adhesive. Brush or aerosol.
3M 08984	Adhesive cleaner/wax remover. Hand application with cloth.

---

**APPLICATION EQUIPMENT**

---

**SATA Schutz Gun Model UBE**

Specifications:

Air consumption ..... 200 litres/min. (7cu/ft. min.) @ 45PSI

Weight ..... 660grams (23.3oz)

Manufactured and supplied by:

Sata Gmbh

Minden Industrial Ltd.

16 Greyfriars Road

Moreton Hall

Bury St. Edmunds

Suffolk IP32 7DX

Tel. (01284) 760791

The Sata Schutz Gun is approved for the re-treatment of vehicle underbody areas with protective coatings as supplied in 1-litre (1.76pt.), purpose-designed, 'one-way' containers. The screw thread fitting (female on the gun) will fit most Schutz-type packs.

Full operating details are supplied with the equipment.



**NOTE: Always clean gun after use with the appropriate solvent.**

**Sata HKD1 Wax Injection Equipment**

The Sata HKD1 is approved by Rover for use in all cavity wax re-treatment operations. The equipment comprises a high quality forged gun with 1-litre capacity pressure feed container, a flexible nylon lance, 1100mm (43.3in.) straight steel lance and hooked wand lance. A quick-change coupling is a standard fitting to enable lances to be easily interchanged. The lances each have their own spray pattern characteristics to suit the type of box section to be treated.

The Sata HKD1 is covered by a 12 month warranty. All replacement parts and service are obtainable from the suppliers.

**Cooper Pegler Falcon Junior Pneumatic (Airless)**

Manufacturer and supplier:  
Cooper Pegler & Co. Ltd.  
Burgess Hill  
Sussex RH15 9LA  
Tel. 04 446 42526

Intended primarily for applying transit wax, the Falcon Junior pneumatic sprayer has a 5-litre (1 gal.) container with integral hand pump. This high quality unit provides a simple and effective means of wax spraying without the need for compressed air or additional services.

A selection of nozzles, lances and hoses together with a trigger valve assembly incorporating a filter enable the sprayer to be used in a variety of applications. These include general maintenance, wax injection and paint application. All parts are fully replaceable and include a wide range of nozzle configurations.

The Falcon Junior is fitted with Viton seals and is guaranteed for 12 months.

**3M Application Equipment**

Manufacturer:  
3M UK PLC  
Automotive Trades Group  
3M House  
PO Box 1  
Market Place  
Bracknell  
Berks. RG12 1JU  
Tel. (01344) 858611

All 3M equipment is available from local trade factors or 3M refinishing factors.

**3M Caulking Gun 08002**

A lightweight, robust metal skeleton gun designed to accommodate 325mm (12.8in.) cartridge for dispensing sealants etc. This gun facilitates rapid cartridge loading and features a quick-release lever for accurate material ejection and cut-off control.

**3M Pneumatic Cartridge Gun 08012**

An air line fed gun for application of 3M cartridge products. Excellent ease of application for a smooth sealant bead, and incorporates a regulator valve for additional control.

Other 3m applicator equipment available:

**3M Pneumatic Applicator Guns**

Air line fed gun for application of 3M sachet sealers (Part No. 08006 for 200ml [6fl/oz.] and 310ml [9fl/oz.] sachets, and Part No. 08007 for all size sachets including 600ml [18fl/oz.]).

**3M Applicator Gun 08190**

For application of 3M Structural Adhesive 08120.

**3M Inner Cavity Wax Applicator Gun**

Features 750mm (29.6in.) flexible tube and using 1-litre (1.76pt.) canisters, this approved equipment is available from all 3M refinishing factors.

Other 3m applicator equipment available:

**Heavy Duty Manual Gun.**

---

**MATERIALS GUIDE**

---

**3M Automotive Structural Adhesive 08120**

a two-part epoxy structural adhesive, with 'automix' twin-cartridge dispenser. For doorskin and for bonding panel stiffeners. Supplied as twin pack for use in small trigger gun (No. 08190).

**3M Bolted Panel Sealer 08572**

Preformed strip 20mm (0.8in.) wide x 2mm (0.08in.) thick supplied in 4.6 metre (81.2in.) reels. Permanently flexible with good adhesion, for sealing wing to body joints and other bolted or riveted panels.

**3M Body Caulking 08568**

Thumb-applied sealing compound supplied in 60-packs of preformed strips 300mm (11.8in.) long x 6mm (0.24in.) wide. For sealing large openings and fissures. Non-hardening, does not dry out or crack, can be overpainted immediately.

**3M Drip-Chek Sealer Heavy 08531**

For use on vertical fissures and seams up to 3mm (0.12in.) wide for a firm but flexible seal which will not harden or shrink. Self-levelling, will not sag on vertical surfaces. May be worked with a tool or smoothed with a wet finger.

Supplied in 150ml (4.5fl/oz.) tubes.

**3M Drip-Chek Sealer Clear 08401**

An easily flowing sealer similar to Drip-Chek Heavy but of clear consistency. Ideal for an almost invisible spot weal over finished paintwork. Can be overpainted or even mixed with paint colour to form a self-coloured sealant.

Supplied in 150ml (4.5fl/oz.) tubes.

**3M Super Seam Sealer 08537**

A brushable sealer designed to simulate original factory-applied sealer on all overlap joints such as floor pans, wheel arches, boot and load space seams and fuel filler cap surrounds. Resistant to oil, petrol and water. Should be brushed on in **ONE** direction only for best results.



**WARNING: Must be stored under conditions applicable to highly flammable materials.**

**3M Flexseal 08684, 08689 AND 08694**

A high solid, non-shrinking, polyurethane body sealer for use in either a hand gun or pneumatic applicator gun. Excellent adhesion and sealing properties. Resistant to oil, petrol and water. Supplied in 310ml (9fl/oz.) cartridges and in a choice of black, white or grey.

**3M Polyurethane Sachet Sealer 08703, 08783, 08788**

Similar to Flexseal polyurethane but available in collapsible foil sachets in 310ml (9fl/oz.) and 600ml (18fl/oz.) sizes with a choice of three colours: black, grey or white.

**3M Windscreen Sealer 08509**

Non-hardening sealant for dry-glazed, weatherstrip-type windscreens. Applied with applicator gun.

Supplied in 310ml (9fl/oz.) cartridges.

**3M Spray Schutz 08877, Body Schutz 08861**

Flexible, rubberised, fast-drying coating which dries to a black textured finish.

Spray Schutz supplied in 600ml (18fl/oz.) aerosols. Spray Schutz and Body Schutz also supplied in 1-litre (1.76pt.) cartridges to fit Schutz Gun.

**3M Flexible Parts Repair Material 05900**

A fast-curing, two-part system for repairing minor damage to plastic bumpers, spoilers, valances etc. Dries in 30 mins.

Supplied as two-pack 320ml (10fl/oz.) kit.

**3M Weld Thru' SEALER 08625**

For anti-corrosion protection between spot welded panels. Brush application.

Supplied in 1-litre (1.76pt.) canisters.

**3M Bodygard**

Rubber-based, stone chip protective coating for panels. Fast drying, low bake compatible and may be overpainted. Varying textures obtainable depending on type of finish required. Available in black (1-litre [1.76pt.] pack 08858, aerosol 08158) or grey (1-litre [1.76pt.] pack 08859, aerosol 08159).

**3M Inner Cavity Wax**

For protective coating on inner panels. Excellent anti-corrosion properties. Available in transparent or amber consistencies, and 1-litre (1.76pt.) canister or 500ml (0.88pt.) aerosol packs.

**3M Zinc Spray 09113**

Anti-corrosive coating for spot welding applications on joints and seams. Supplied in 500ml (0.88pt.) aerosol packs.

**3M Waterproof Cloth Tape YS3998**

Black waterproof tape for sealing door apertures and body box section access holes. Long-lasting, moisture-resistant adhesive will withstand immersion in water.

Supplied in 50-metre (164.2ft.) rolls in a variety of widths.

**3M Adhesive Cleaner and Wax Remover 08984**

For surface preparation before application of most types of adhesive, coating and sealant, also for removal of tar, silicone polish, wax, grease and oil. Non-staining. May also be used for cleaning adhesive remnants from sander disc backing pads.

Supplied in 1-litre (1.76pt.) canisters.



## ELECTRONIC AIR SUSPENSION - EAS

### Description

The Range Rover concept of air suspension is already well established, the system fitted to the New Range Rover is broadly similar. Progressive development has resulted in added features to improve the control and operation of the system.

Air springs provide a soft and comfortable feel to the ride of the vehicle. The use of a microprocessor to control the system exploits the advantages of air suspension.

The system provides a near constant ride frequency under all load conditions resulting in:

- Improved ride quality
- Consistency of ride quality
- Constant ride height
- Improved headlamp levelling

The system provides five ride height settings plus self levelling. Each setting is automatically maintained at the correct height by the system logic with the minimum of driver involvement. Vehicle height is sensed by four rotary potentiometer type height sensors. Height information from each sensor signals the electronic control unit (ECU) to adjust each air spring by switching the solenoid valves to hold, add or release air.

The five height settings are as follows:

#### Standard: Profile

**Low profile:** 25 mm (1 in.) below standard.

**Access:** 65 mm (2.6 in.) below standard. Crawl: It is possible to drive at the access ride height at speeds less than 32 km/h (20 mph), where headroom is restricted.

**High profile:** 40 mm (1.6 in.) above standard.

**Extended profile:** 70 mm (2.75 in.) above standard. This setting is not manually selectable.

### Self levelling

On a coil sprung vehicle the effect of adding weight is for the vehicle to lean either from front to back or side to side unless the increased weight is evenly spread. With air suspension, the system detects this body lean and automatically compensates for it. The vehicle will self level to the lowest corner height for 20 seconds each time the driver exits vehicle and closes the doors.

The system will check vehicle height every 6 hours and make minor corrections, not exceeding 8 mm, (0.31 in) as necessary.

When unloading through the tailgate the system will self level to compensate for the decreased load after door closure.



**NOTE:** If the vehicle is parked on uneven ground or with a wheel or wheels on the kerb, self levelling will lower the vehicle to the lowest spring height.



**CAUTION:** The underside of the vehicle must be kept clear of any obstacles while the vehicle is parked, as self levelling may result in a reduced trim height.



**WARNING:** Before commencing work which requires access to the underside or wheel arches of the vehicle, the suspension must be allowed to relevel. Relevelling is achieved by opening and closing of any of the side doors, while all other doors and tail gate remain closed, and the ignition off.

**EAS must be set in 'high-lock' using TestBook, during any work which does not require chassis to axle displacement. This will hold the suspension in extended profile position, until reset by TestBook.**

## LOCATION OF COMPONENTS

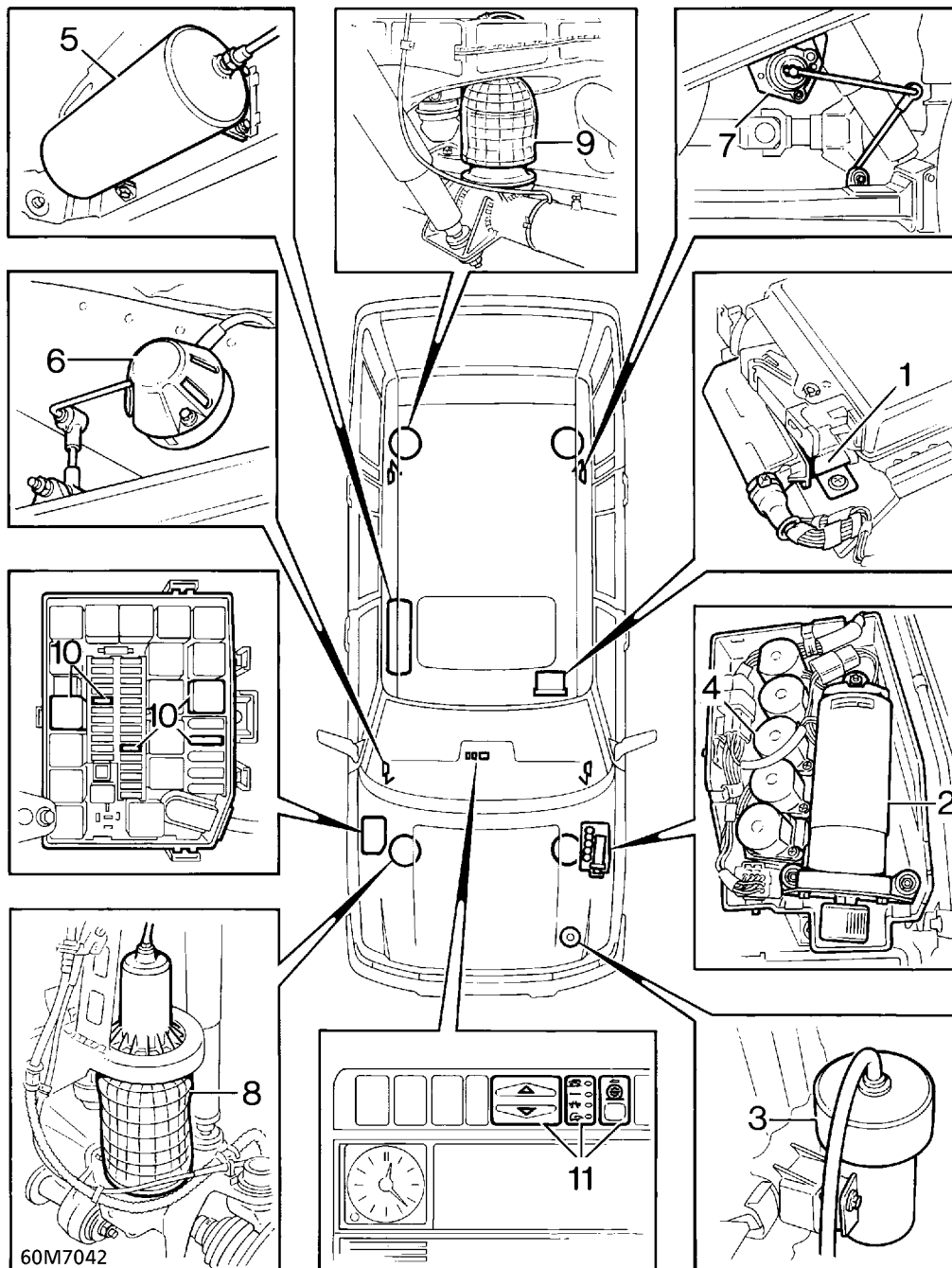

## Key to location of components

- |                            |                        |
|----------------------------|------------------------|
| 1. Electrical control unit | 7. Height sensors rear |
| 2. Compressor              | 8. Front air spring    |
| 3. Air dryer               | 9. Rear air spring     |
| 4. Valve block             | 10. Relays, fuses      |
| 5. Reservoir               | 11. Driver controls    |
| 6. Height sensors front    |                        |

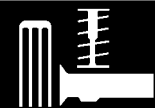

## DESCRIPTION OF COMPONENTS

### Electrical control unit - ECU

The ECU is located underneath the front left hand seat. The ECU maintains the requested vehicle ride height by adjusting the volume in each air spring. It is connected to the cable assembly by a 35 way connector. To ensure safe operation the ECU has extensive on board diagnostic and safety features. The ECU must be replaced in case of failure.

### Air compressor



**NOTE: The air compressor and valve block are contained in the under bonnet unit mounted on the left hand inner wing.**

The air compressor provides system pressure. A thermal switch is incorporated which cuts out compressor operation at 120° C. An air filter is fitted to the compressor head. The filter is renewed every 40,000 kms. (24,000 miles).

### Air dryer

The air dryer is connected into the air line between the compressor and reservoir. It is mounted on the engine air cleaner box. The dryer removes moisture from pressurised air entering the system. All air exhausted from the system passes through the dryer in the opposite direction. The air dryer is regenerative in that exhaust air absorbs moisture in the dryer and expels it to atmosphere.

The air dryer is non-servicable, designed to last the life of the vehicle. However, if any water is found in the system, the air dryer must be replaced.



**CAUTION: If the air dryer is removed from the vehicle the ports must be plugged to prevent moisture ingress.**

### Valve block

The valve block controls the direction of air flow. Air flow to and from the air springs is controlled by seven solenoid operated valves, one for each spring plus an inlet, exhaust and outlet. In response to signals from the ECU, the valves allow high pressure air to flow in or out of the air springs according to the need to increase or decrease pressure. A diaphragm valve operated by the solenoid outlet valve ensures that all exhausted air passes through the air dryer.

Mounted on the valve block is a pressure switch which senses air pressure and signals the ECU to operate the compressor when required. The compressor will operate when the pressure falls between 7.2 and 8.0 bar. It will cut out at a rising pressure of between 9.5 and 10.5 bar.

The valve block contains the following serviceable components: solenoid coils 1 to 6, drive pack and pressure switch.

The valve block must only be dismantled after the correct diagnosis procedure.

### Reservoir

The 10 litre reservoir is mounted on the right hand side of the chassis. One connection acts as air inlet and outlet for the rest of the system. The reservoir stores compressed air between set pressure levels. The reservoir drain plug requires removing to check for moisture in the system every 40,000 kms. (24,000 miles).

### Height sensors

Four potentiometer type height sensors signal vehicle height information to the ECU. The potentiometers are mounted on the chassis and activated by links to the front radius arms and rear trailing links. A height sensor must be replaced in case of failure, and the vehicle recalibrated using TestBook.



### Air springs - front and rear

The air springs consist of the following components:

1. Top plate
2. Rolling rubber diaphragm
3. Piston

Front and rear air springs are of similar construction but are NOT interchangeable. The diaphragm is not repairable, if failure occurs the complete air spring must be replaced

### Driver controls

Mounted in the centre of the dashboard, the driver controls consist of an UP/DOWN switch, an INHIBIT switch and a height setting indicator. For full description. **See this section.**

### Relays, fuses

Located in the under bonnet fuse/relay box are 2 relays, plus 10, 20 and 30 amp fuses.

### DRIVER CONTROLS

**The driver controls are located in the centre of the fascia. The controls consist of:**

1. The HEIGHT CONTROL is a press and release type rocker switch which is used to select the required ride height. The vehicle will not respond until switch is released. All movements selected by operation of this switch are indicated by the ride height indicator lights located next to the switch.
2. The INHIBIT switch is a mechanically latching switch. When selected it modifies the automatic height changes of the system, for further details. **See Electrical Trouble Shooting Manual.** Selection of 'inhibit' is indicated by illumination of the switch tell-tale lamp, which is also bulb tested with the ride height indicator.
3. High indicator light.
4. Standard indicator light.
5. Low indicator light.
6. Access indicator light.
7. Instrument pack warning light.

### Indicator lights

When the ignition key is turned to position 2 all four indicator lights, the air suspension warning light and the inhibit switch will be illuminated continuously. When the engine is started, the lights will remain illuminated for 2 seconds, after which the current ride height will be indicated. Two indicators will be illuminated if the vehicle is between ride heights, with the selected height flashing. When the new height is achieved the indicator will be illuminated constantly and the previous height indicator extinguished. The inhibit switch indicator is illuminated while it is activated. Both switches are illuminated with sidelights switched on. Additional driver information is given by the message centre in the instrument pack. For details of the messages. **See this section.**

### Air suspension warning lamp

This amber lamp is located in the instrument pack. The lamp will be constantly illuminated when driving at high ride height and will flash when vehicle is at extended height. The lamp will also illuminate if a fault within the system is detected. A bulb check is provided when the ignition switch is turned to position 2 and for 2 seconds after vehicle start.



## HEIGHT SETTINGS

### Standard ride height

With the Inhibit switch off (unlatched), at speeds below 80 km/h (50 mph) the standard ride height indicator will be illuminated.

Standard vehicle ride height is maintained under all load conditions. This also maintains headlamp levelling.

### Low ride height

Low ride height is automatically selected when the vehicle speed exceeds 80 km/h (50 mph) for at least 30 seconds with the inhibit switch off. Low ride height indicator lamp will flash during height change and standard ride height indicator will extinguish when low ride height is attained.

Standard ride height is automatically selected when the vehicle speed drops below 56 km/h (35 mph) for at least 30 seconds with the inhibit switch off.

The driver can select low ride height at any speed. With the vehicle at low ride height, depressing the inhibit switch (latched) will result in the vehicle maintaining low ride height regardless of speed.

The height control switch can be used to change between low and standard ride heights regardless of speed.

### Access mode

This position eases access to and from the vehicle. With the vehicle stationary, doors and tailgate closed, park brake applied, foot brake released and gearshift in 'Park' on automatic vehicles, press and release the down switch. The vehicle will descend to access mode. While the vehicle is descending, the access indicator will flash. When access mode is attained, the indicator will remain constantly illuminated, and standard ride height lamp will be extinguished.

Access mode can be selected up to 40 seconds before stopping vehicle. On stopping, applying the handbrake, releasing the foot brake and selecting 'Park' on automatic vehicles, the vehicle will lower to access mode.

It is possible to select access up to 40 seconds after switching engine off.



**NOTE: Opening a door or tailgate will immediately stop vehicle height change. When the door is closed, the height change will be completed. If the door is open for more than thirty seconds, the system will need 'reminding' of the new height when the door is closed.**

Driving the vehicle will result in vehicle rising automatically to standard ride height. Alternatively standard ride height can be achieved by closing all doors, starting engine and pressing the up switch. The standard indicator will flash during the change. When standard ride height is attained the indicator will remain constantly illuminated and access indicator will be extinguished.

### Crawl mode

In areas where height is restricted, the vehicle may be driven in access mode. To achieve this, ensure the inhibit switch is unlatched and select access mode. When access height is achieved, press the inhibit switch, the lamp will be illuminated. The message centre in the instrument binnacle will beep three times and display AIRSUS ISOLATED. The vehicle may now be driven at speeds up to 32 km/h (20 mph).

If the vehicle is accelerated to 16 km/h (10 mph) the message centre will beep three times and display SLOW 20 MPH (32 KM/H) MAX.

If speed exceeds 40 km/h (25 mph) the vehicle will rise to low profile, with low warning flashing. On slowing to 32 km/h (20 mph) the vehicle will lower to access mode with access warning illuminated.

When speed falls below 8 km/h (5 mph) the message centre will beep three times and display AIRSUS ISOLATED.

To cancel crawl mode, release the inhibit switch or depress the up switch.

### High ride height

This position is used to improve approach and departure angles and when wading. When at standard ride height, pressing the up switch will select high ride height provided the road speed is below 56 km/h (35 mph). The high ride height indicator will flash during the height change. When the change is complete the indicator will remain constantly illuminated, and standard ride height indicator will be extinguished. The indicator in the instrument pack will also be illuminated. If speed exceeds 56 km/h (35 mph), the vehicle will return to standard profile.

### Extended ride height

This position is achieved if chassis is grounded leaving wheel or wheels unsupported. Initial ECU reaction is to lower (deflate) affected springs. After a timed period the ECU detects no height change, it therefore reinflates springs to extended profile in an attempt to regain traction. The position will be held for 10 minutes, after which time the vehicle will automatically return to standard ride height.

Pressing the down switch will lower vehicle 20 mm to high profile.

If vehicle speed exceeds 56 km/h (35 mph) the vehicle will immediately lower to standard ride height. This speed could be achieved, for example, by wheelspin.

---

### VEHICLE TRANSPORTATION

---

New vehicles are transported from the factory with the EAS system electronically 'frozen' in access mode. When road speed exceeds 40 km/h (25 mph), the vehicle will rise to low ride height. It will return to access mode if speed falls below 38.4 km/h (24 mph). This condition is cancelled at pre-delivery inspection, by entering the appropriate command via TestBook.

#### Vehicle transportation/recovery



**CAUTION: When an air suspension vehicle is secured to a transporter using the chassis lashing eyes, there is a possibility due to air leakage, self levelling or operation of ride height controls that the tension of the securing straps will be lost. To prevent this the ride height should be set to access mode before securing to transporter.**

If the engine cannot be run and the vehicle is not in access mode, the vehicle can be transported, but it must be secured to the transporter by the roadwheels, not the chassis.

---

### ELECTRICAL TROUBLESHOOTING

---

For electrical details of the air suspension circuit. **See *Electrical Trouble Shooting Manual*.**



**SYSTEM OPERATION**

Numbers refer to pneumatic circuit diagram

Air is drawn through the inlet filter (1) to the compressor (2), where it is compressed to 10 ± 0,5 bar.

Compressed air passes to the air dryer (3) where moisture is removed as it flows through the dryer desiccant. The desiccant in the lower portion of the dryer becomes wet.

Dried air passes through a non-return valve NRV1 to the reservoir (4).

The 3 non-return valves (6) ensure correct air flow. They also prevent loss of spring pressure if total loss of reservoir pressure occurs.

The pressure switch (5) maintains system pressure between set limits by switching on and off the compressor via an ECU controlled relay.

For air to be admitted to an air spring (10), the inlet valve (7) must be energised together with the relevant air spring solenoid valve (9).

For air to be exhausted from an air spring, the exhaust valve (8) must be energised together with the relevant air spring solenoid valve.

The solenoid diaphragm valve (12) ensures that all air exhausted to atmosphere passes through the dryer. Exhausted air passes vertically downwards through the dryer. This action purges moisture from the desiccant and regenerates the air dryer.

Air is finally exhausted through the system air operated diaphragm valve (13) and to atmosphere through a silencer (14) mounted below the valve block.

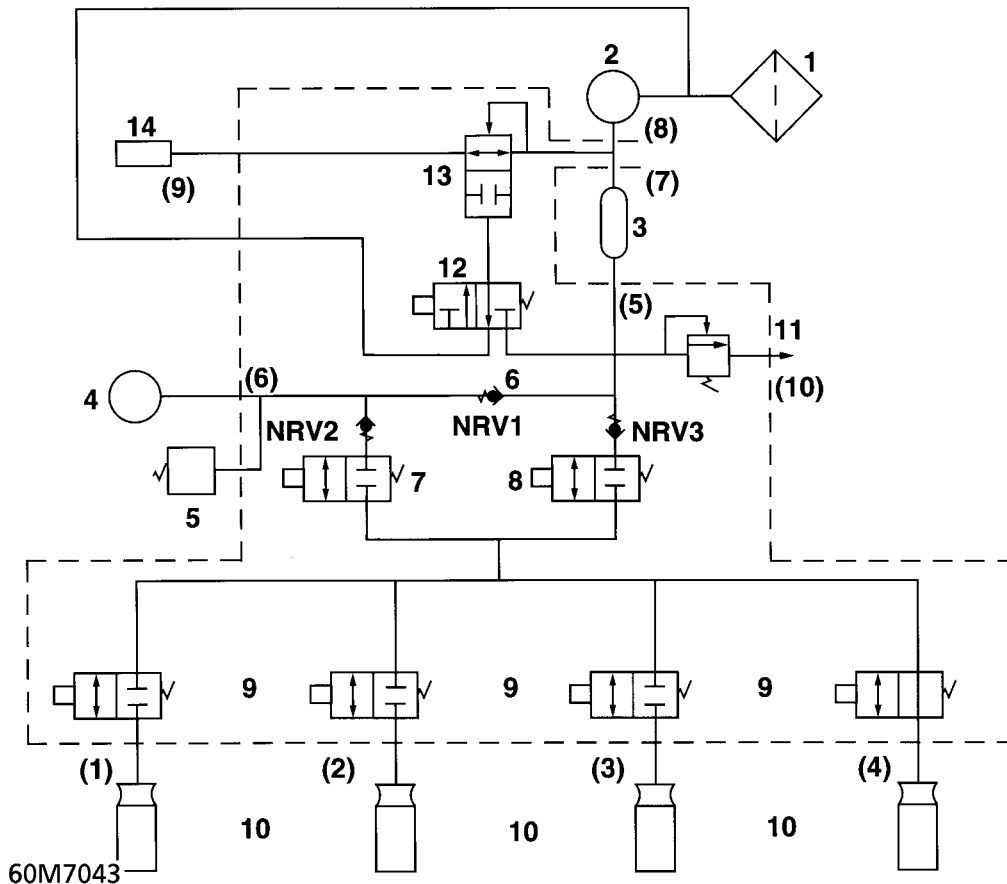

60M7043

---

**FRONT SUSPENSION**

---

**Description**

The front suspension design on the New Range Rover allows maximum wheel travel and axle articulation, providing good ground clearance without loss of traction or directional stability.

Near constant ride frequency under all load conditions is achieved by utilizing advancements in suspension geometry complemented to control and operation of the air suspension system. **See this section.**

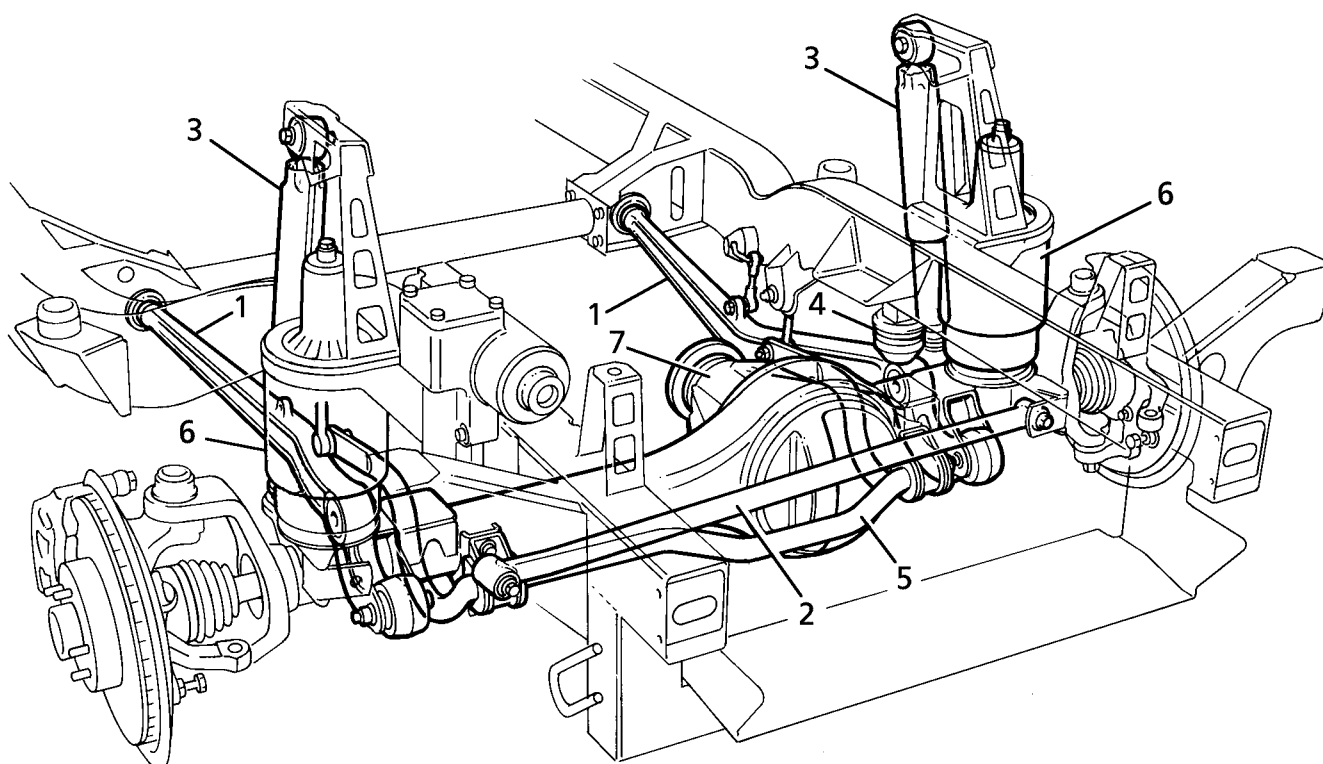

60M7040

**Front axle suspension**

1. Radius arms
2. Panhard rod
3. Shock absorbers
4. Bump stops
5. Anti-roll bar
6. Air springs
7. Front axle

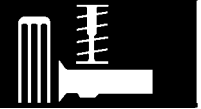

Long front radius arms (1) are fitted to the front axle (7) and provide maximum axle articulation which is vital for off road performance. The radius arm, comprising a forged steel link with twin front mountings using ferrule rubber bushes, is secured to fabricated mounting brackets welded to the front axle. Flexible rubber bushes are used on a stem end joint to secure the rear of the radius arm to a mounting on the chassis cross member as shown in 60M7040. The vehicle height sensors are also linked to the front radius arms; for full details of the height settings. **See this section.**

A panhard rod (2), which ensures that the axle remains centrally located, is fitted transversely and also uses ferrule rubber bush mountings at both axle and chassis locations. An anti-roll bar (5) is fitted to the front axle to control body roll and directional stability. Two rubber bearing bushes, with retaining straps, secure the anti-roll bar to the front axle, while ball jointed links, suspended from the chassis, support the rear of the anti-roll bar.

Conventional telescopic shock absorbers (3), used to control body movement, are secured to fabricated towers which are welded to the chassis. The upper fixing uses a single retaining bolt passing through a flexible rubber bush. The lower fixing of the shock absorber comprises of a stem type mounting with two flexible rubber bushes and support washers secured to an axle mounting by a single retaining nut. Cellular foam bump stops (4) are fitted under the chassis adjacent to the air springs (6) and prevent possible damage that could occur should there be excessive axle to chassis movement. Should there be a loss of air pressure in the air springs the vehicle can still be driven safely at a speed not exceeding 35 mph (56kph) with the bump stops resting on the axle, although this will result in a hard ride. The loss of air pressure should be investigated as soon as possible. The bump stops are 'progressive' and will reform from a compressed state when the load is released.

SYSTEM COMPONENTS - DISTRIBUTED SRS SYSTEM

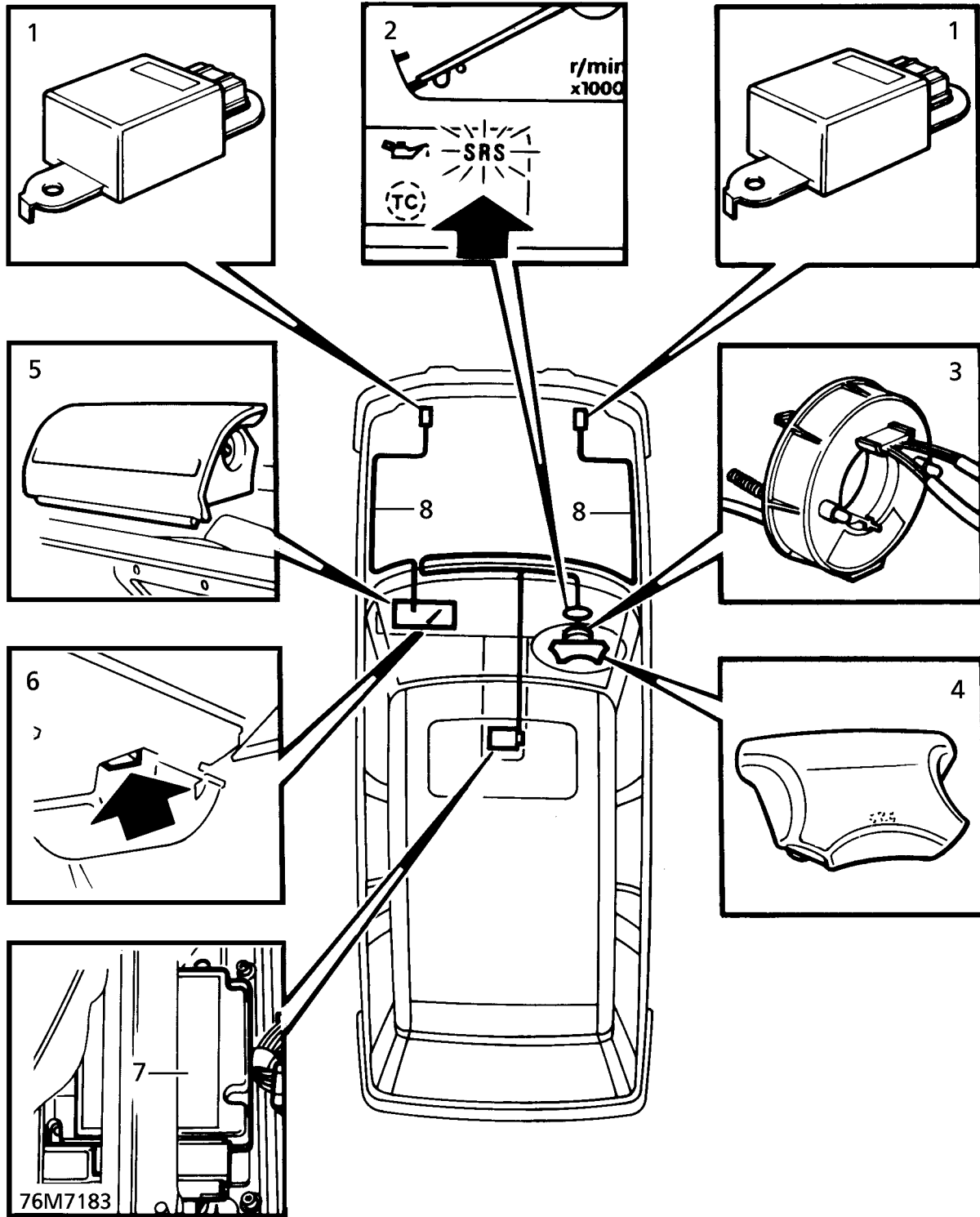

- 1. Airbag crash sensors
- 2. SRS warning light (airbag)
- 3. Rotary coupler
- 4. Driver's airbag module
- 5. Passenger's airbag module

- 6. Airbag diagnostic socket
- 7. Airbag diagnostic control unit
- 8. Airbag harness

## OPERATION

The airbag supplementary restraint system (SRS) is a safety device which, when used in conjunction with the seat belt, is designed to protect the driver and front passenger by operating when the vehicle receives a frontal impact (in the area shown) exceeding a certain set speed.

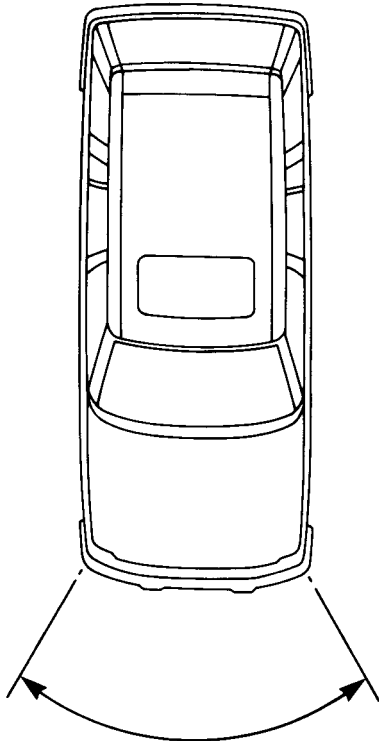

## SRS warning light (airbag)

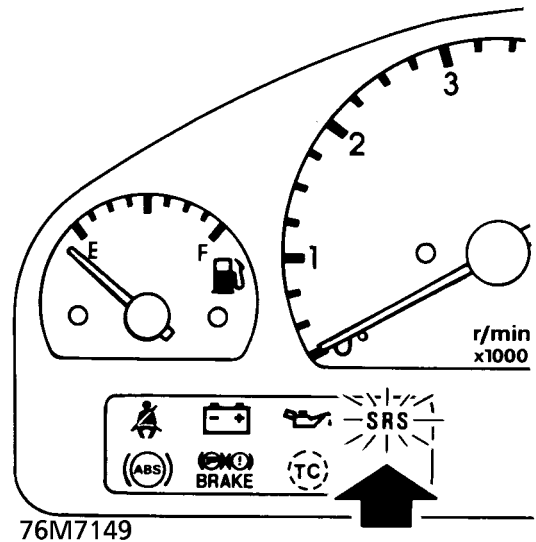

The warning light in the instrument pack illuminates after the electrical circuits are switched on whilst a system check is carried out. After about 7 seconds the warning light will go out. The system checks the airbag diagnostic control unit, airbag crash sensors and the airbag harness.

In the event of a fault in the system the warning light will illuminate and begin modulating. The airbag diagnostic control unit logs the fault which can only be accessed using **TestBook**.

In the event of a frontal impact, when the airbag diagnostic control unit and one of the airbag crash sensors senses the impact, the diagnostic control unit triggers the airbag modules which fires an igniter. This in turn ignites tablets of sodium azide which generate a large amount of Nitrogen gas leading to airbag inflation in approximately 30 milli-seconds.

When fully deployed the airbag offers additional protection to the front seat occupant. As an occupant moves into the airbag it immediately discharges the gas from vent holes to provide progressive deceleration and reduce risk of injuries. The whole process is completed in approximately 0.3 seconds.



**WARNING: All the airbag system components, including the wiring harness, MUST be renewed after the airbags have deployed.**



SYSTEM COMPONENTS - SINGLE POINT SENSED  
SRS SYSTEM

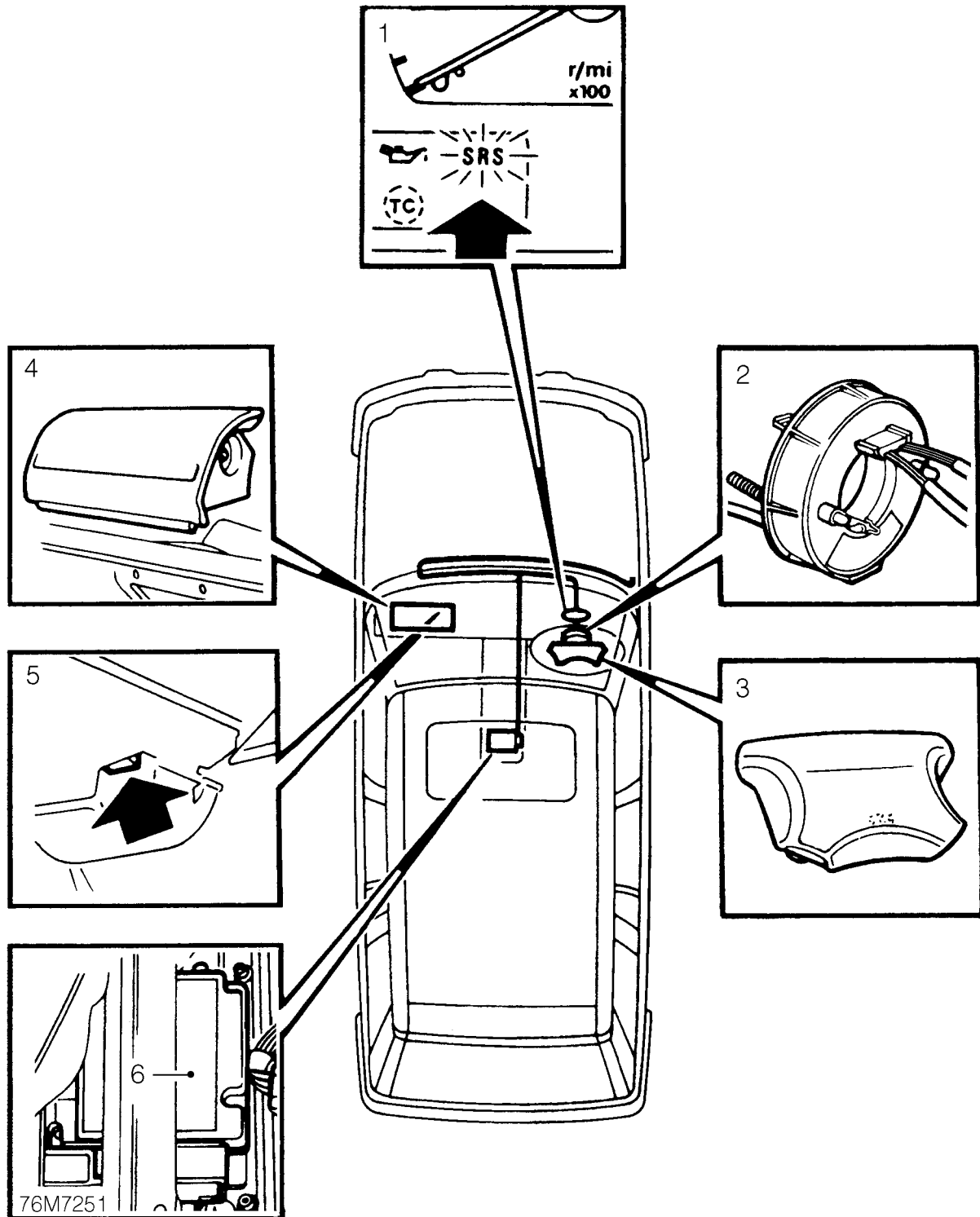

- |   |  |
|---|--|
| <ul style="list-style-type: none"> <li>1. SRS warning light (airbag)</li> <li>2. Rotary coupler</li> <li>3. Driver's airbag module</li> </ul> | <ul style="list-style-type: none"> <li>4. Passenger's airbag module</li> <li>5. Airbag diagnostic socket</li> <li>6. Airbag diagnostic control unit (DCU)</li> </ul> |
|---|--|

## OPERATION

The airbag supplementary restraint system (SRS) is a safety device which, when used in conjunction with the seat belt, is designed to protect the driver and front passenger in the event of a frontal collision.

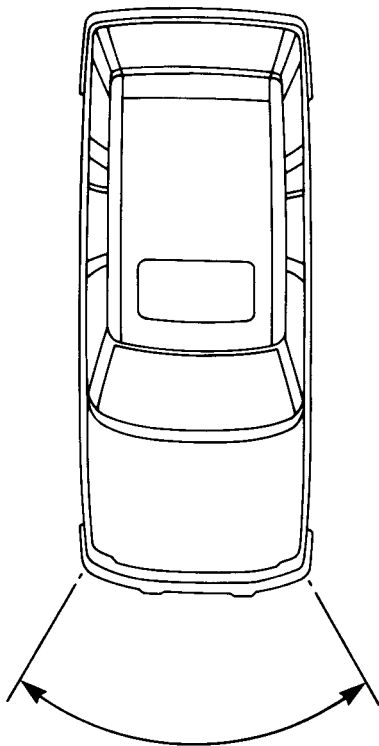

76M7148

The diagnostic control unit (DCU) is able to distinguish between rough road conditions and a frontal collision. If the DCU detects a frontal collision of sufficient severity, it sends a fire signal to the airbag module initiators. The initiators ignite tablets of sodium azide which generate a large amount of Nitrogen gas leading to airbag inflation in approximately 30 milli-seconds.

As the occupant moves into the fully inflated airbag, the nitrogen gas discharges from vent holes in the rear of the airbag. As the airbag deflates, it provides progressive deceleration for the occupant and reduces the risk of injuries. The process from airbag initiation to deflation is completed in approximately 0.3 seconds.



**WARNING: All the airbag system components, including the wiring harness, MUST be renewed after airbag deployment.**

## SRS warning light

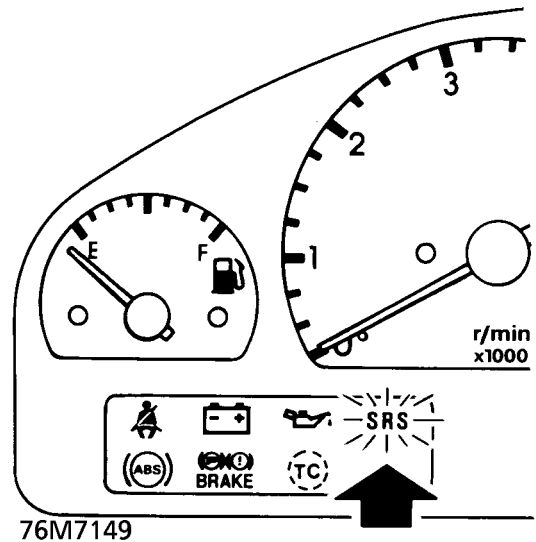

76M7149

The airbag system carries out a system check every time the ignition is switched to position 2. During the system check, the instrument pack warning light is illuminated to provide a bulb check. The warning lamp is extinguished when the system check is complete, after about 5 seconds.

If a system fault is found during the initial system check or subsequently during driving, the warning light will illuminate, indicating to the driver that there is a fault with the airbag system. With the warning light on, the airbag system will not operate in the event of a frontal collision. The DCU records system faults in an internal memory. The memory can be interrogated using TestBook via the diagnostic socket located on the passenger side fascia closing panel.



**GENERAL PRECAUTIONS**

**Making the system safe**

Before commencing repair work on any airbag components:

- Remove the key from the starter switch.

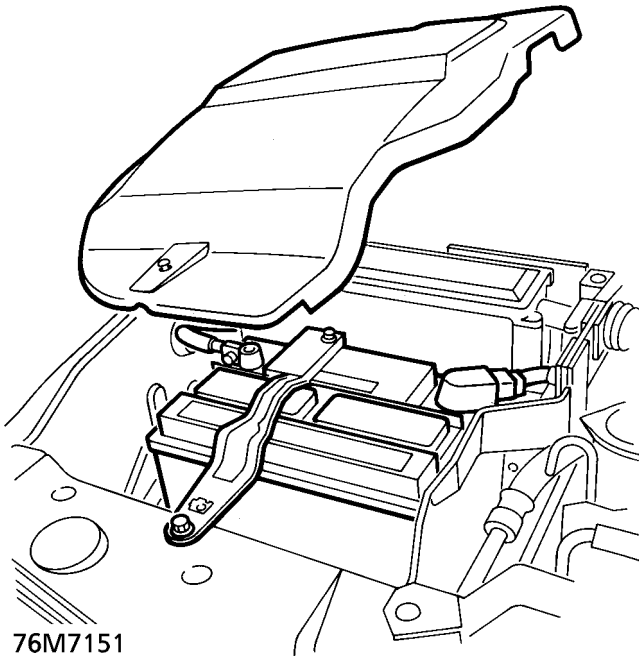

**Care Points**

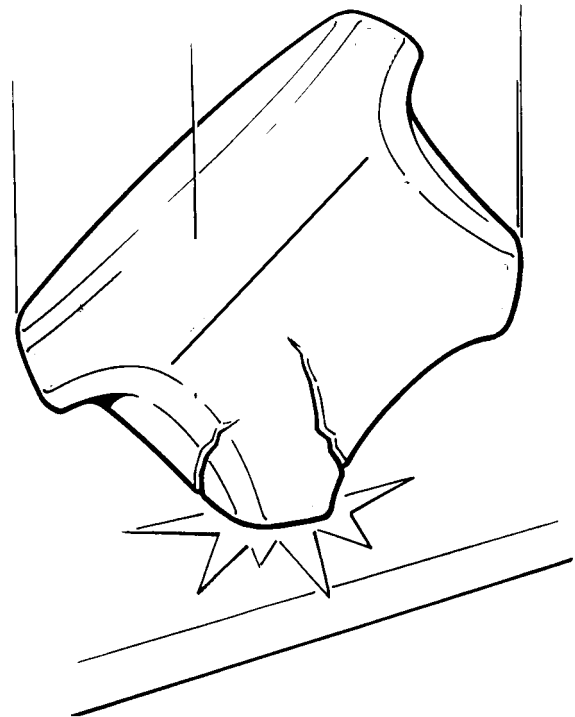

- Disconnect both battery leads, earth lead first.
- Wait 10 minutes for DCU back-up power circuit to discharge.



**WARNING:** The airbag module contains Sodium Azide which is poisonous and extremely flammable. Contact with water, acid or heavy metals may produce harmful or explosive compounds. Do not dismantle, incinerate or bring into contact with electricity.

## NEVER

- Drop any airbag system component.



**NOTE: The airbag DCU is a shock sensitive device and must be handled with extreme care.**

- Wrap arms around an airbag module.
- Attach anything to the airbag cover.
- Attempt to repair any component.

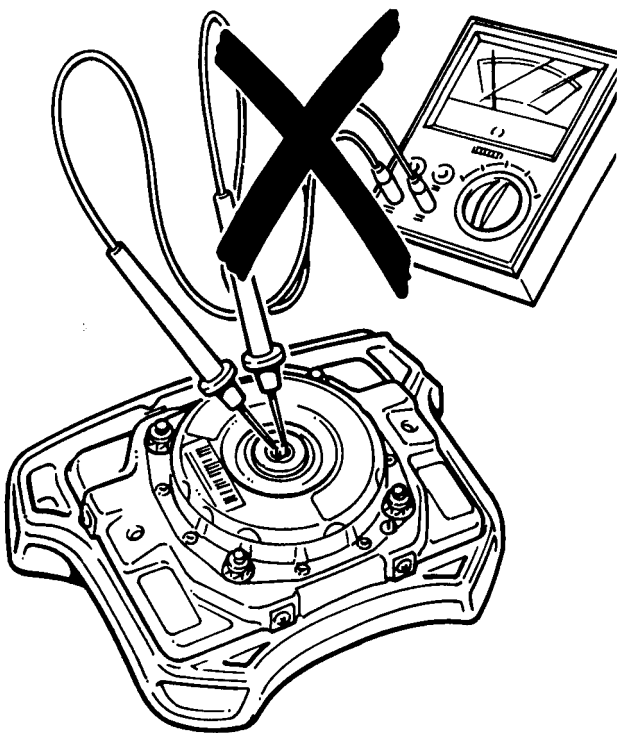

76M7152

- Apply electrical power to a component unless instructed to do so by an approved test procedure.
- Transport airbag modules in the passenger compartment of a car. Use the luggage compartment.
- Install any airbag component that shows signs of being dropped or improperly handled, such as dents, cracks or deformation.
- Install used airbag components from another vehicle. When repairing an airbag system, use only genuine new parts.

## ALWAYS

- Carefully inspect any airbag component before installation.
- Check airbag harness is correctly routed.
- Check airbag connectors are fully mated and latched after completion of work.

## Airbag handling and storage

- Do not try to dismantle the airbag module. It has NO serviceable parts. Once an airbag has been deployed, it cannot be repaired or reused.
- Be careful that the airbag module receives no strong shocks, it could deploy.
- Special bolts are necessary for installing the airbag module. Do not use other bolts.

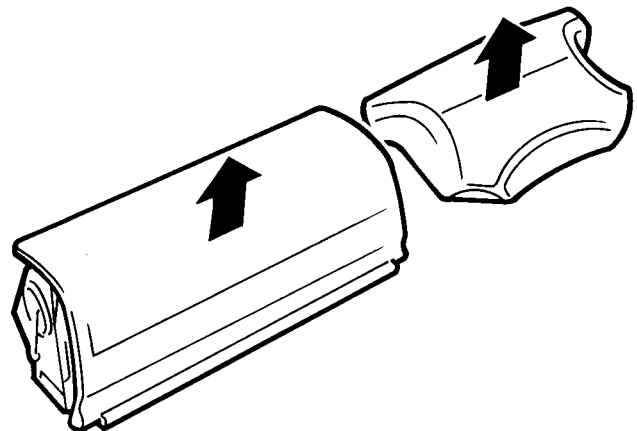

76M7184

For temporary storage of the airbag module during service, observe the following precautions.

- Always keep components dry.
- Always carry the airbag module with the pad surface face up.
- Store the removed airbag module with the pad surface face up.
- Do not allow anything to rest on the airbag module.
- Place the airbag module in the designated storage area.



- If no designated storage area is available, then the luggage compartment of the vehicle should be used. Always lock the luggage compartment when an airbag module is stored in it and inform the workshop supervisor.



**WARNING:** If the airbag module is improperly stored face down, accidental deployment could propel the unit with enough force to cause serious injury.

- Store the removed airbag assembly on a secure flat surface away from any electrical equipment or high heat source (exceeding 85° C/185° F) and free of any oil, grease, detergent or water.



**CAUTION:** Improper handling of storage can internally damage the airbag module, making it inoperative. If you suspect the airbag module has been damaged, install a new unit and refer to the Deployment/Disposal Procedures for disposal of the damaged airbag.

**Overnight storage**

Airbag modules are classed as explosive devices and as such must be stored in an approved secure steel cabinet which has been registered by the local authority.

**CRASH SENSOR INSPECTION - DISTRIBUTED SRS SYSTEM ONLY**

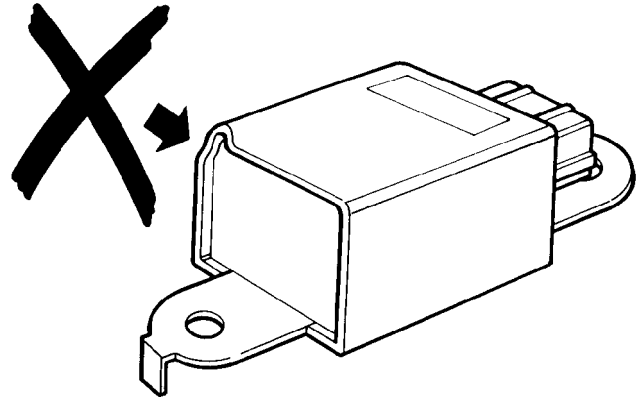

76M7154

1. After any degree of front body damage, inspect both front crash sensors. Replace a sensor if there are any signs of dents, cracks or deformation.

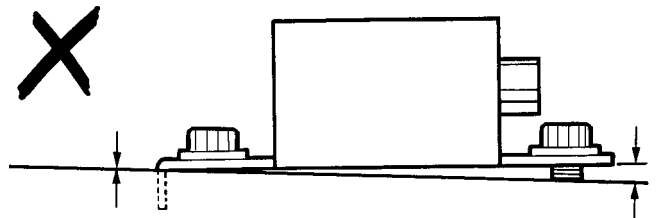
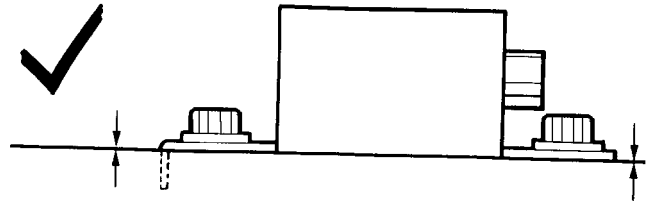

76M7187

2. Ensure the sensors are installed correctly. There must be no gap between the sensor and body of the vehicle. Use the fixing screws supplied with the sensor and tighten to the correct torque. Tighten front sensor fixing before rear sensor fixing.



**CAUTION:** Take extra care when painting or doing body work in the vicinity of the sensors. Avoid direct exposure of the sensors or harness to heat guns, welding or spraying equipment.

## WIRING AND CONNECTORS

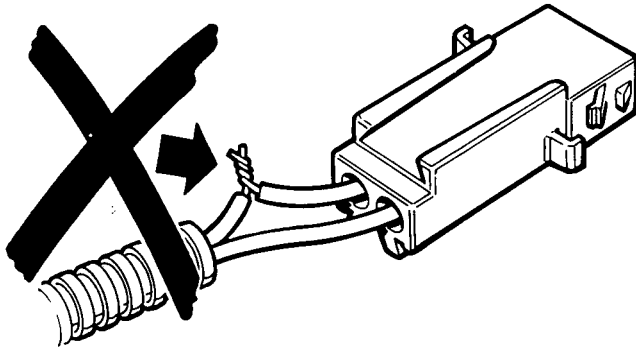

76M7156

- Never attempt to modify, splice or repair the airbag wiring. Never install electronic equipment such as; a mobile telephone, two-way radio or in-car entertainment system in such a way that it interferes electrically with the airbag wiring.

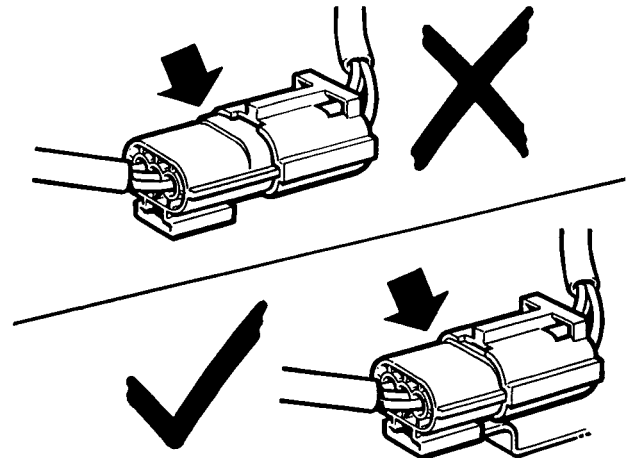

76M7158

- Ensure all airbag harness connectors are mated correctly and securely fastened. Do not leave the connectors hanging loose.

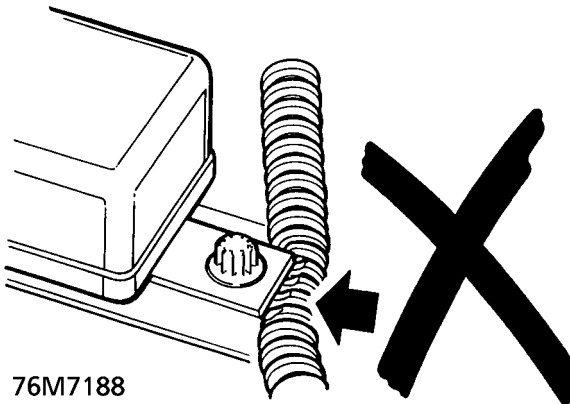

76M7188

- Always ensure airbag wiring is routed correctly. Be careful to avoid trapping or pinching the airbag wiring. Look for possible points of chaffing.
- Always use specified earth fixings tightened to the correct torque. Poor earthing can cause intermittent problems that are difficult to diagnose.



**WARNING LABELS**

A combination of symbols/icons are displayed (either in a suitable, prominent position or attached to the component itself) to indicate:

- The need for caution when working in close proximity to SRS components.
- The publication where suitable reference and advice can be found (usually Repair Manual or Owner's Handbook).

**NOTE:** It is imperative that before any work is undertaken on the SRS system that the appropriate publication is read and understood.

The following list indicates current locations for warning labels. Exact positions may vary dependent on legislation and market trends.

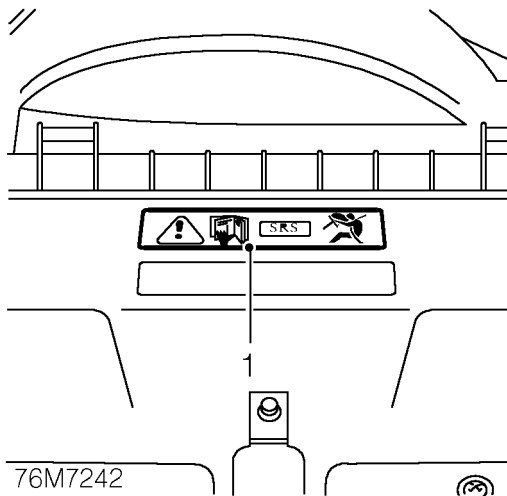

76M7242

1. Bonnet locking platform. Refer to Owner's Handbook for information on the SRS system.

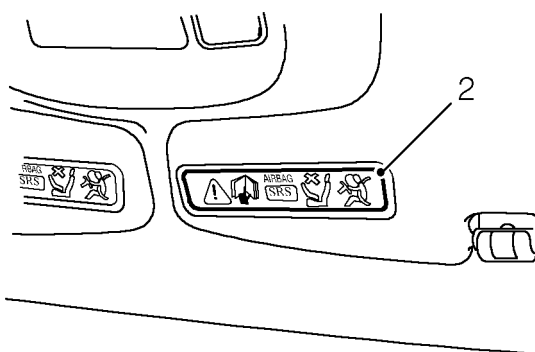

76M7443

2. Driver's and passenger's sun visor. Refer to

Owner's Handbook for information on the SRS system.

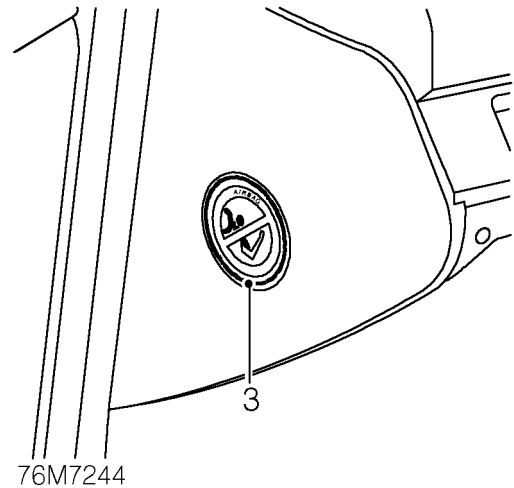

76M7244

3. End of fascia, passenger's side (not all markets). Do not use rear facing child seat in passenger seat of vehicles fitted with passenger airbag.

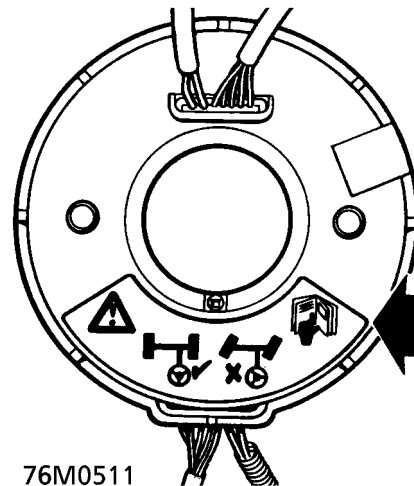

76M0511

4. Rotary coupler. Ensure wheels are positioned in straight ahead position before removal and refitting. Do not rotate mechanism. Refer to the Repair Manual for information on the airbag system.

## 5. Airbag modules

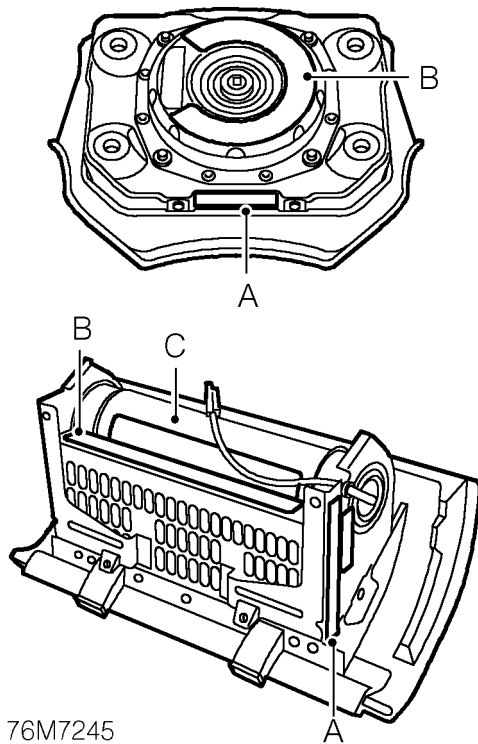

76M7245

A- Land Rover bar code. The code number(s) must be recorded if the airbag module is to be replaced.

B- Warning, the use of gas generators is permitted only for occupant restraint systems in vehicles fitted with airbags. Not repairable. Handling is permitted only by authorized personnel. Do not use any live electrical test equipment. Do not open, remove or install in another vehicle. Risk of malfunction and personal injury. Upon deployment, an airbag unit which is not properly mounted may become a dangerous projectile. Refer to Repair Manual for further instructions.

C- Danger Poison. Keep out of reach of children. Contains sodium azide and sodium nitrate. Contents are poisonous and extremely flammable. Contact with acid or heavy metals may produce toxic gases.

---

**VEHICLE RECOVERY**

---

**Towing - airbag not deployed**

Normal towing procedures are unlikely to cause an airbag to deploy. However, as a precaution, switch the ignition off and then disconnect both battery leads. Disconnect the negative lead first.

**Towing - airbag deployed**

Once the driver's airbag has been deployed the vehicle must have a front suspended tow. However, as a precaution, switch the ignition off and then disconnect both battery leads. Disconnect the negative '-' lead first.





**AIRBAG MANUAL DEPLOYMENT**

If a vehicle is to be scrapped and contains an undeployed airbag module, the module must be manually deployed. This operation should only be carried out using the following recommended manual deployment procedure.

Before deployment is started, the deployment tool self test should be carried out.

**Deployment tool SMD 4082/1 self test procedure**

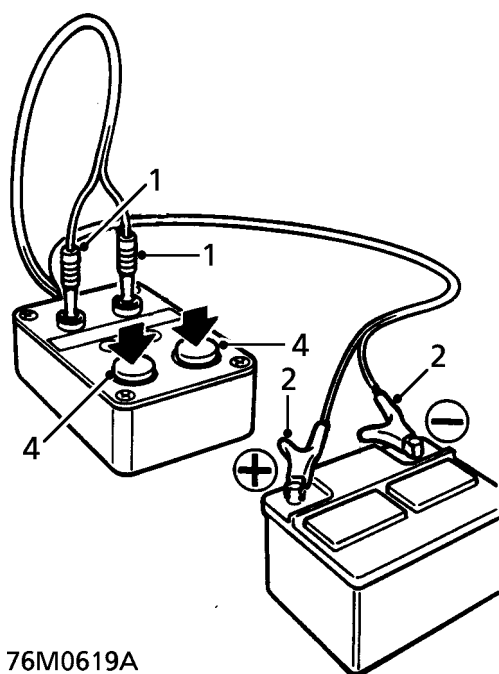

76M0619A

1. Insert blue and yellow connectors of tool lead into corresponding sockets on face of tool.
2. Connect crocodile clips of second tool lead to battery, red to positive and black to negative.
3. Red "READY" light should illuminate.
4. Press and hold both operating buttons.
5. Green "DEFECTIVE" light should illuminate.
6. Release both operating buttons.
7. Red "READY" light should illuminate.
8. Disconnect tool from battery.
9. Disconnect blue and yellow connectors from tool face sockets.
10. Self test now complete.

**Deployment with module fitted to vehicle**

These guidelines are written to aid authorised personnel to carry out the safe disposal of the airbag module when fitted to the vehicle.

**WARNING:** Only use the Land Rover approved deployment equipment. Deploy airbag modules in a well ventilated, designated area. Ensure airbag module is not damaged or ruptured before deploying.

**Driver's airbag module**

1. Carry out deployment tool self test.
2. Remove driver's side fascia closing panel. *See CHASSIS AND BODY, Repair.*

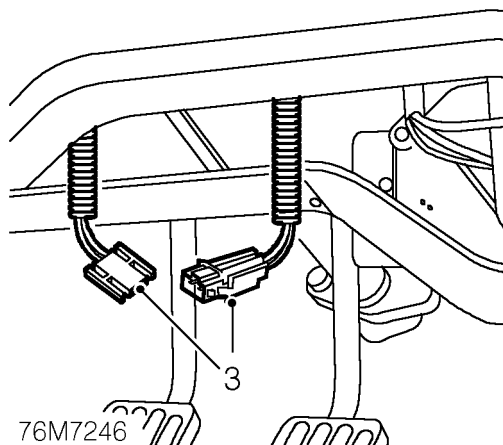

76M7246

3. Release airbag multiplug from fascia and disconnect multiplug.

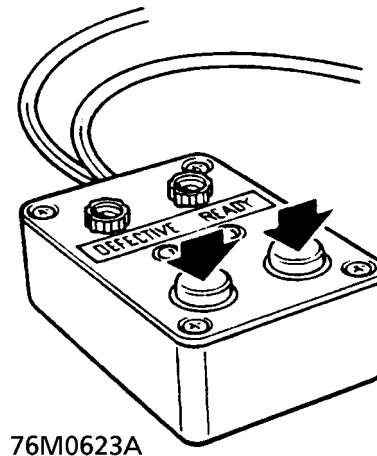
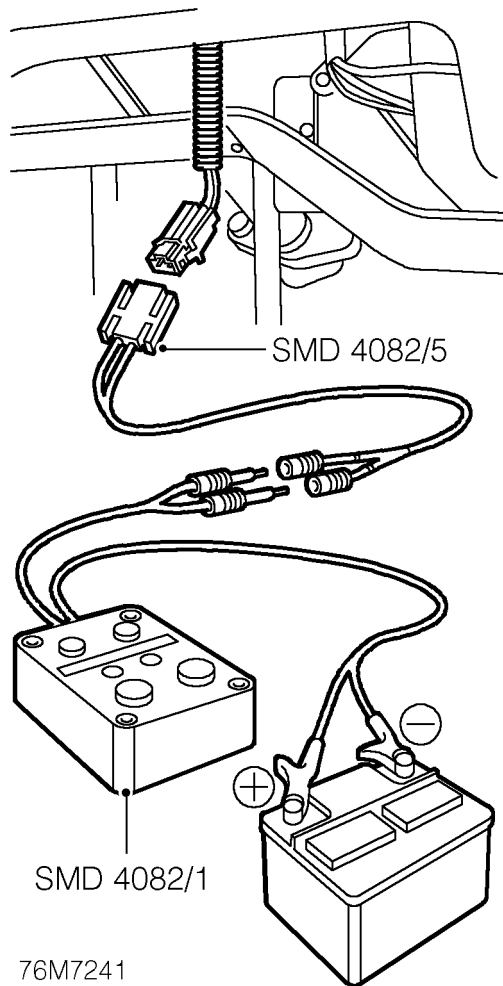

7. Press both operating buttons to deploy airbag module.
8. DO NOT return to airbag module for 30 minutes.
9. Using gloves and face mask, remove airbag module from steering wheel, place airbag module in plastic bag and seal bag.
10. Transport deployed airbag module to designated area for incineration.



**NOTE: DO NOT transport airbag module in the vehicle passenger compartment.**

11. Scrap all remaining parts of airbag system. DO NOT re-use or salvage any parts of the airbag system, including steering wheel or steering column.



**WARNING: Ensure tool SMD 4082/1 is not connected to battery.**

4. Connect flylead SMD 4082/5 to airbag connector.
5. Connect flylead SMD 4082/5 to tool SMD 4082/1.



**WARNING: Ensure airbag module is secure within steering wheel.**

6. Connect tool SMD 4082/1 to battery.



**WARNING: Ensure all personnel are standing at least 15 metres away from vehicle.**

**Passenger's airbag module**

1. Carry out deployment tool self test.
2. Remove glove box assembly. **See CHASSIS AND BODY, Repair.**

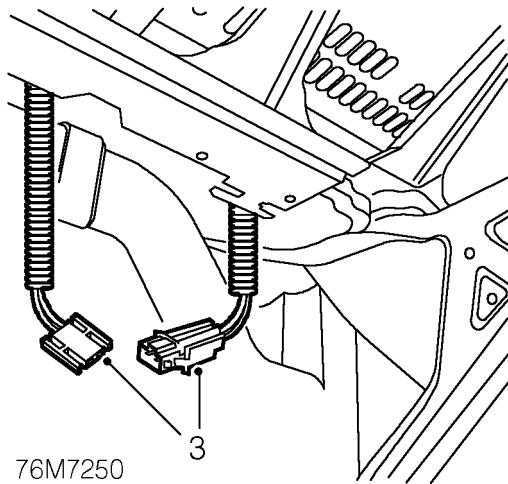

3. Release airbag connector from fascia and disconnect multiplug.

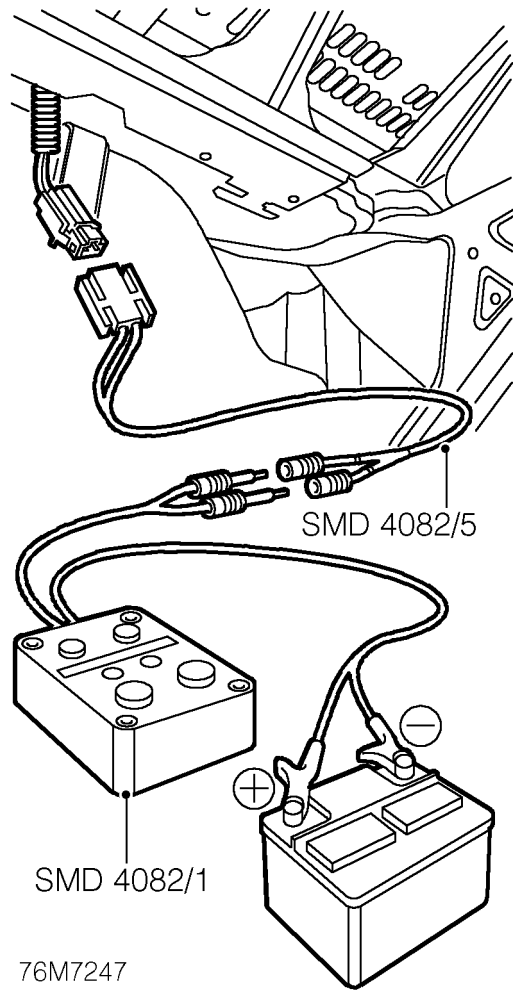

**! WARNING: Ensure tool SMD 4982/1 is not connected to battery.**

4. Connect flylead SMD 4082/5 to harness connector.
5. Connect flylead SMD 4082/5 to tool SMD 4082/1.

**! WARNING: Ensure airbag module is secure within fascia.**

6. Connect tool SMD 4082/1 to battery.

**! WARNING: Ensure all personnel are standing at least 15 metres away from vehicle.**

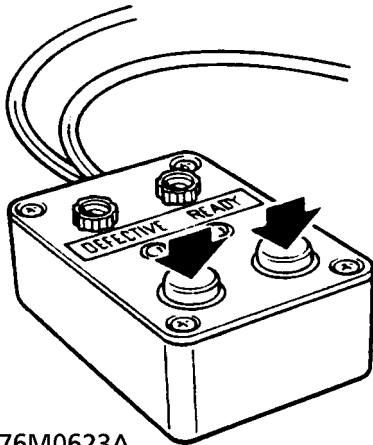

76M0623A

7. Press both operating buttons to deploy airbag module.
8. DO NOT return to airbag module for 30 minutes.
9. Using gloves and face mask, remove airbag module from fascia. Place airbag module in plastic bag and seal bag.
10. Transport deployed airbag module to designated area for incineration.



**NOTE: DO NOT transport airbag module in the vehicle passenger compartment.**

11. Scrap all remaining parts of airbag system. DO NOT re-use or salvage any parts of the airbag system.

Following the deployment of the airbags, the following components must be replaced:

SRS wiring harness,  
 Airbag crash sensors (distributed system only),  
 Rotary coupler,  
 Driver's airbag module,  
 Passenger's airbag module,  
 Airbag diagnostic control unit,  
 Complete steering wheel assembly including associated switches.

### PRECAUTIONS

Dimensions 'A' AND 'B' on steering column must be within tolerance.

Dimension 'A' 3.0 - 4.0 mm

Dimension 'B' 91.5 - 92.8 mm

If dimension 'A' is incorrect replace steering column.

If dimension 'B' is incorrect replace steering column, and pedal box.

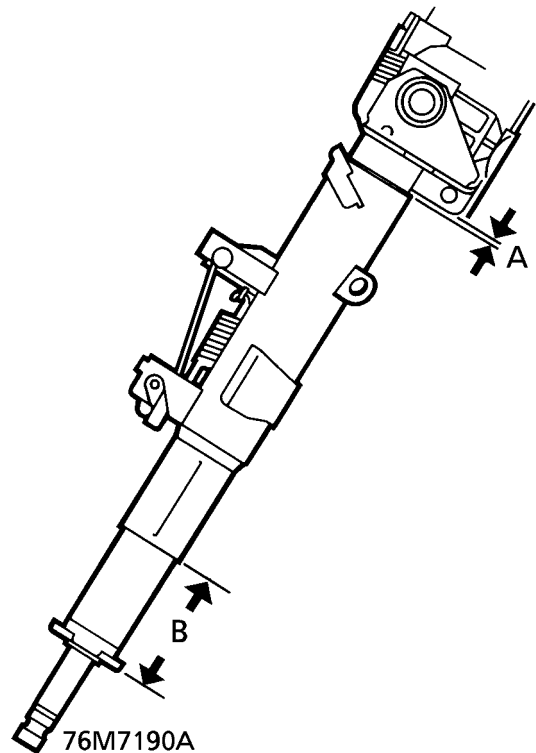

76M7190A



**Deployment with module removed from vehicle**

These guidelines are written to aid authorised personnel to carry out the safe disposal of airbag modules when removed from the vehicle.



**WARNING: Only use Land Rover approved deployment equipment. Deploy airbag modules in a well ventilated, designated area.**

**Driver's airbag module**

1. Carry out deployment tool self test.
2. Remove airbag module from steering wheel. *See Repair.*

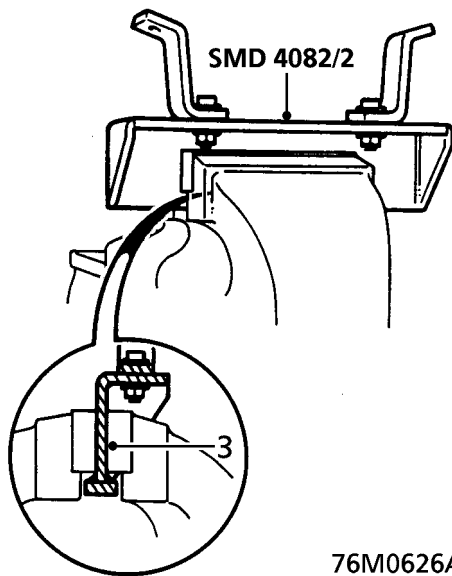

76M0626A

3. Position tool SMD 4082/2 in vice, ensuring that vice jaws grip tool above bottom flange to prevent possibility of tool being forced upwards from vice. Tighten vice.

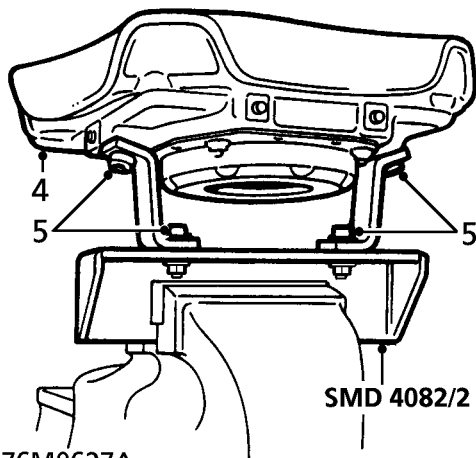

76M0627A

4. Secure airbag module to tool SMD 4082/2. Ensure module is correctly secured using both fixings.
5. Ensure airbag module mounting brackets are secure.

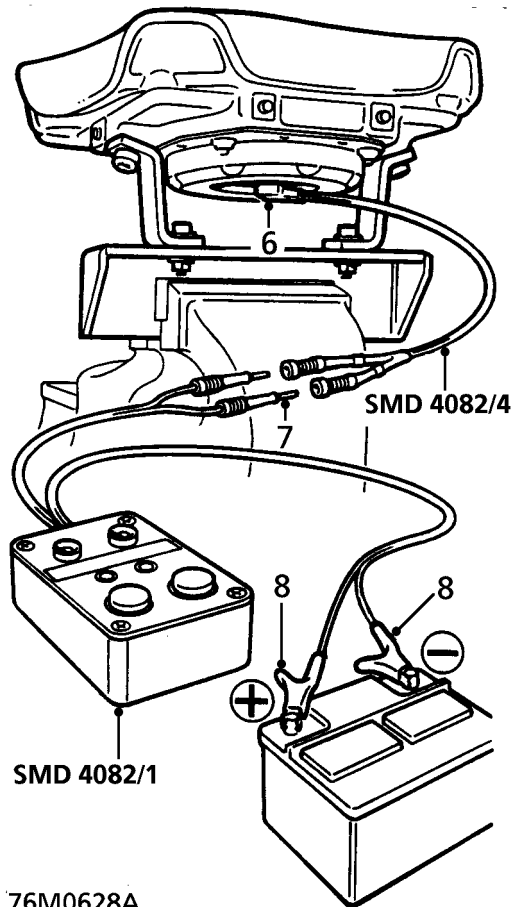

76M0628A



**WARNING: Ensure tool SMD 4082/1 is not connected to battery.**

6. Connect flylead SMD 4082/4 to airbag module.
7. Connect flylead SMD 4082/4 to tool SMD 4082/1.



**WARNING: Do not lean over module whilst connecting.**

8. Connect tool SMD 4082/1 to battery.



**WARNING: Ensure all personnel are standing at least 15 metres away from module.**

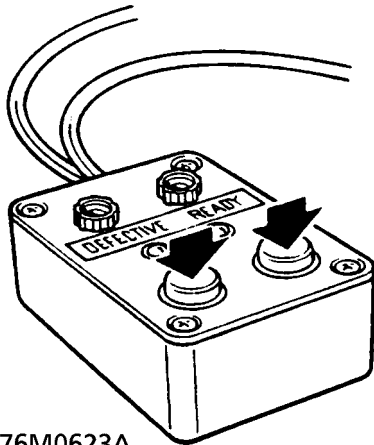

76M0623A

9. Press both operating buttons to deploy airbag module.
10. DO NOT return to airbag module for 30 minutes.
11. Using gloves and face mask, remove airbag module from tool, place airbag module in plastic bag and seal bag.
12. Wipe down tool with damp cloth.
13. Transport deployed airbag module to designated area for incineration



**NOTE: DO NOT transport airbag module in the vehicle passenger compartment.**

### Passenger's airbag module

1. Carry out deployment tool self test.
2. Remove airbag module from fascia. *See Repair.*

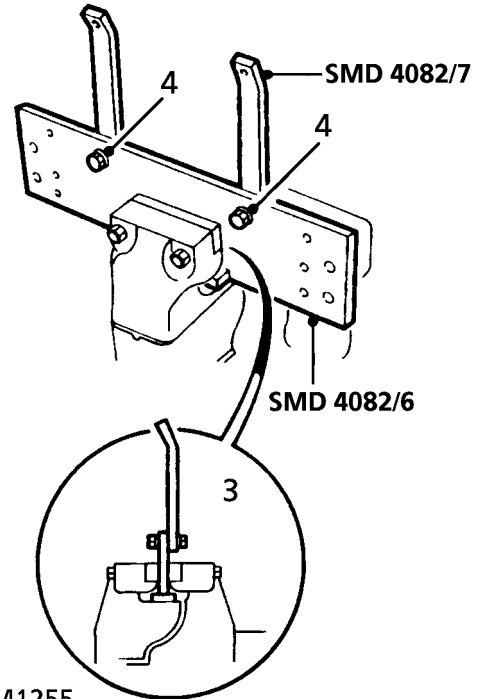

76M1255

3. Position tool SMD 4082/6 in vice, ensuring that vice jaws grip tool above bottom flange to prevent possibility of tool being forced upwards from vice. Tighten vice.
4. Position brackets SMD 4082/7 to tool; lightly tighten bolts.

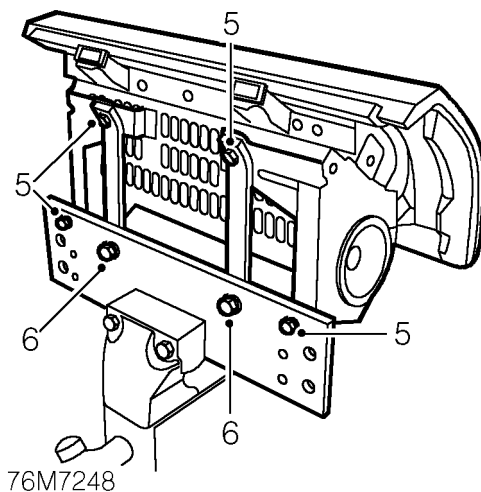

76M7248

5. Secure airbag module to tool SMD 4082/6. Ensure module is correctly secured using all fixings.



6. Ensure airbag module mounting brackets are secure.

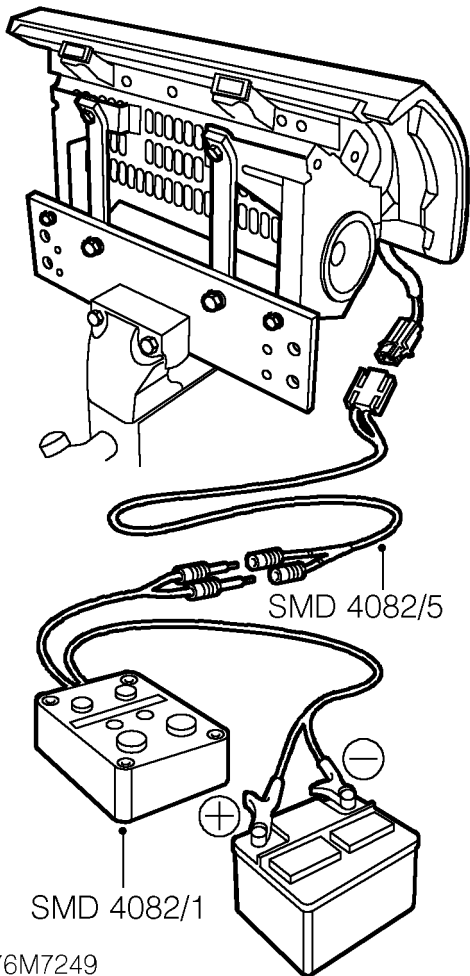

**WARNING: Ensure tool SMD 4082/1 is not connected to battery.**

7. Connect flylead SMD 4082/5 to airbag module.

8. Connect flylead SMD 4082/5 to tool SMD 4082/1.



**WARNING: Do not lean over module whilst connecting.**

9. Connect tool SMD 4082/1 to battery.



**WARNING: Ensure all personnel are standing at least 15 metres away from module.**

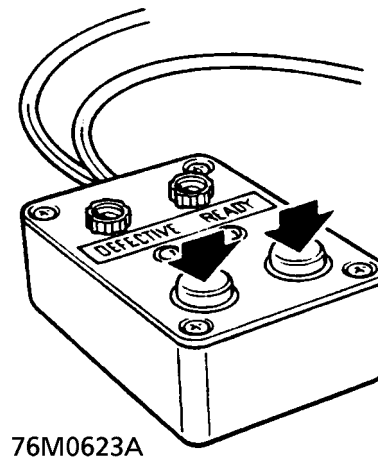

10. Press both operating buttons to deploy airbag module.
11. DO NOT return to airbag module for 30 minutes.
12. Using gloves and face mask, remove airbag module from tool, place airbag module in plastic bag and seal bag.
13. Wipe down tool with damp cloth.
14. Transport deployed airbag module to designated area for incineration



**NOTE: DO NOT transport airbag module in the vehicle passenger compartment.**



**AIRBAG MODULE - PASSENGER SIDE**

Service repair no - 76.73.69



**WARNING:** All the airbag system components, including the wiring harness, **MUST** be renewed after the airbags have deployed.

**Remove**

1. Disconnect both battery terminals, disconnect negative lead first.
2. Remove glove box assembly. **See CHASSIS AND BODY, Repair.**
3. Release and disconnect air bag module multiplug.

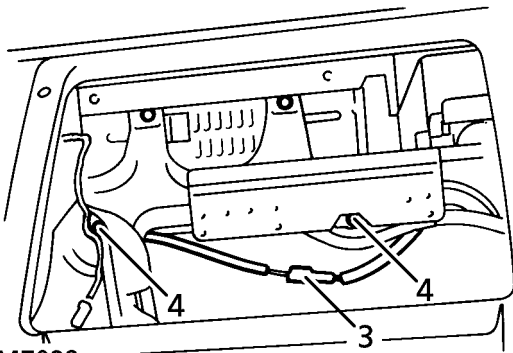

76M7029

4. Remove 4 bolts and washers (E-10 Torx Bit) securing air bag module to fascia frame.
5. Carefully release and remove air bag module.

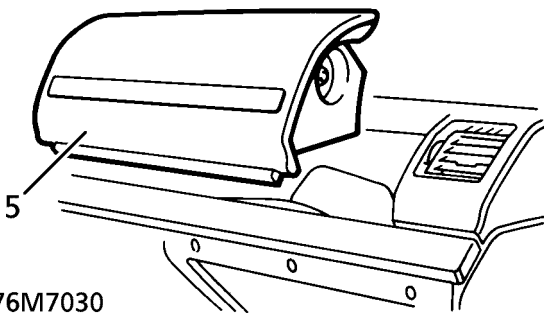

76M7030



**CAUTION:** Store the airbag module correctly. **See this section.**

**Refit**



**NOTE:** If a new airbag module is being fitted the serial numbers must be recorded.

6. Carefully fit air bag module to fascia. Fit Torx bolts, and washers.
7. Tighten bolts to **9 Nm. (7 lbf.ft)**
8. Connect air bag module multiplug and secure to location.
9. Fit glove box assembly. **See CHASSIS AND BODY, Repair.**
10. Connect battery terminals, fit battery cover and secure with turnbuckles.
11. Check Supplementary Restraint System using **TestBook** .



## SRS ECU

Service repair no - 76.73.72

## Remove



**WARNING:** Always disconnect negative lead from battery first. Disconnection of positive lead with negative lead connected risks short circuit and severe sparking through accidental grounding of spanner. Personal injury could result.

1. Disconnect both battery terminals.
2. Remove centre console. *See CHASSIS AND BODY, Repair.*
3. Lift rear of sound deadener pad from transmission tunnel.

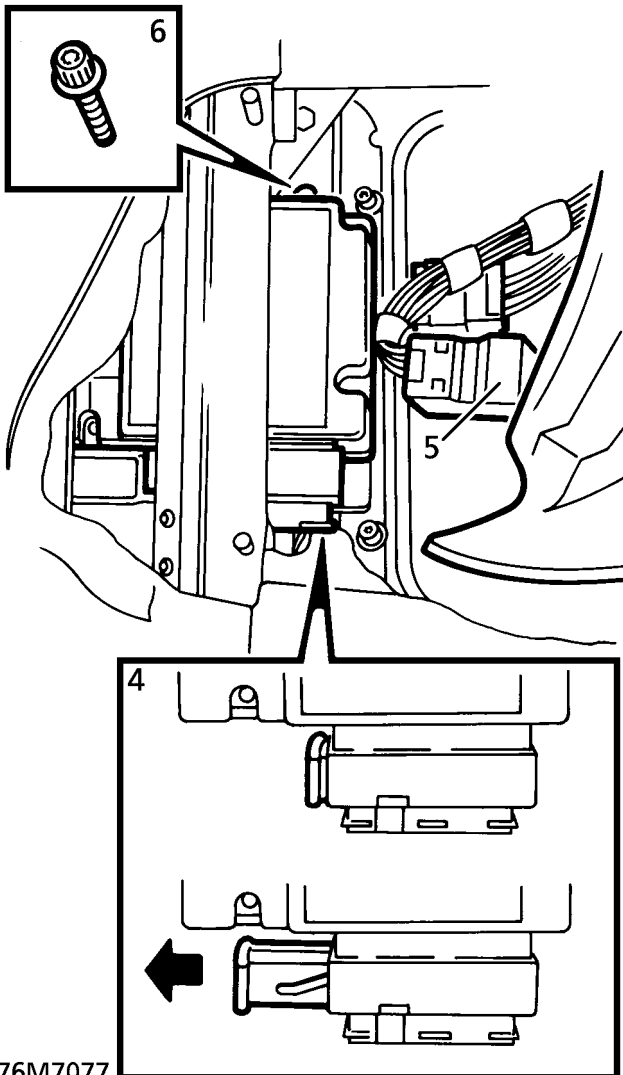

76M7077

4. Disconnect SRS ECU multiplug.

5. Release 2 multiplugs from bracket.
6. Remove 2 bolts securing ECU to bracket. Remove ECU.

## Refit

7. Reverse removal procedure.



**SRS HARNESS - SINGLE POINT SENSED SYSTEM**

Service repair no - 76.73.73

The SRS harness is incorporated into the fascia harness. **See ELECTRICAL, Repair.**

**SRS HARNESS - DISTRIBUTED SYSTEM**

Service repair no - 76.73.73

**Remove**

1. Raise the vehicle.



**WARNING: Support on safety stands.**

2. Remove battery. **See ELECTRICAL, Repair.**
3. Remove centre console. **See CHASSIS AND BODY, Repair.**
4. Remove passenger air bag module. **See this section.**
5. Remove radio. **See ELECTRICAL, Repair.**
6. Remove instrument pack binnacle. **See INSTRUMENTS, Repair.**
7. Remove 5 screws securing switch pack to fascia.

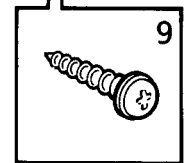
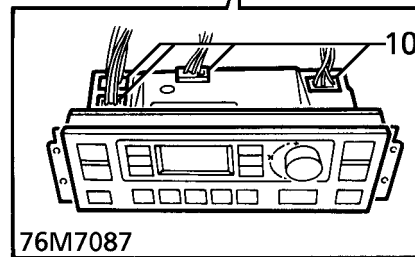
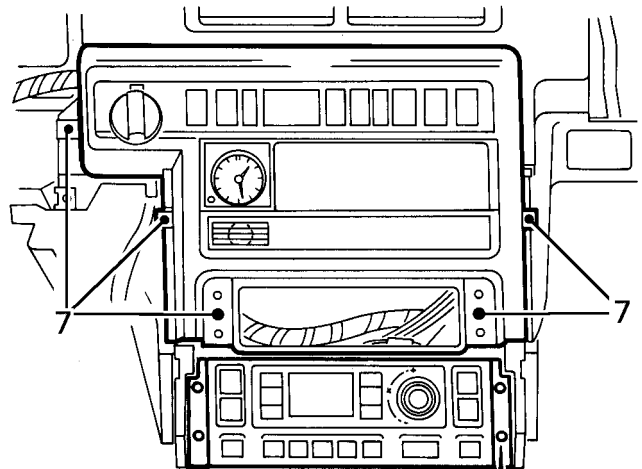

8. Disconnect switches, clock and temperature sensor. Remove switch pack.
9. Remove 4 screws securing heater control panel.
10. Disconnect multiplugs. Remove control panel.
11. Release door aperture seal adjacent to A post lower trim panels.
12. **Driver's side - LHD automatic vehicles only:** Remove 3 bolts securing foot rest. Remove foot rest.

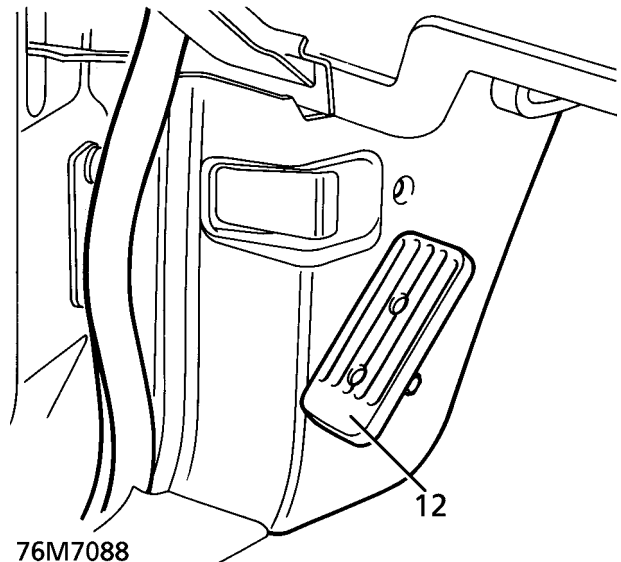

13. Remove screw securing each A post lower trim panel. Release panels from sprag clips. Remove both trim panels.

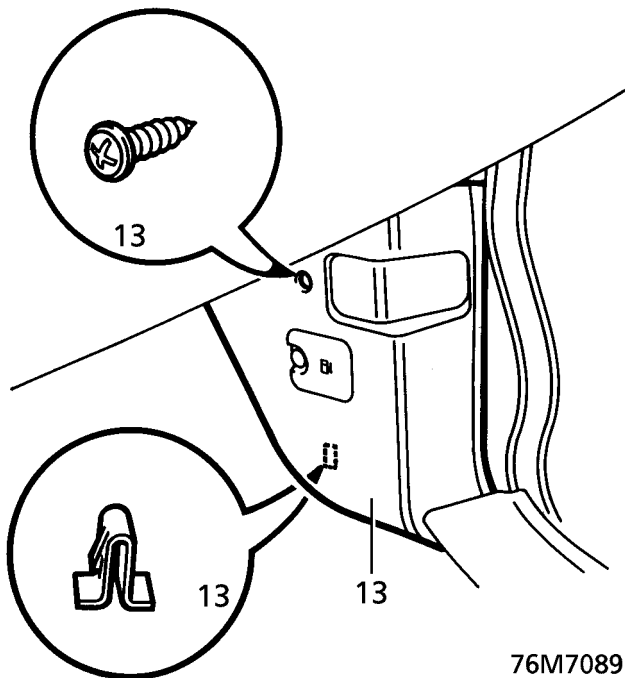

76M7089

14. Remove 4 scrivet fasteners securing drivers side lower closing panel.

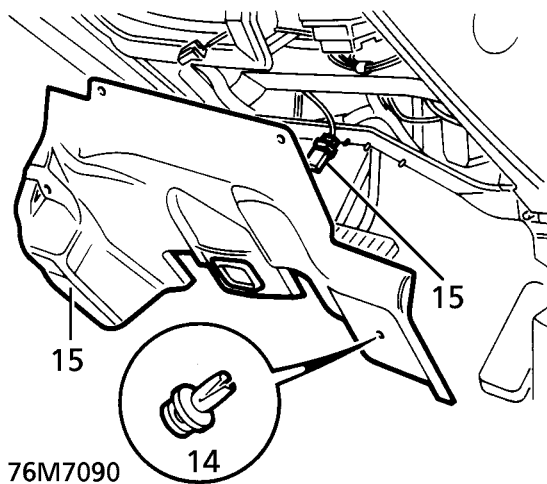

76M7090

15. Disconnect footwell lamp multiplug. Remove closing panel.  
16. Disconnect SRS harness from main harness. Release multiplug from clip.

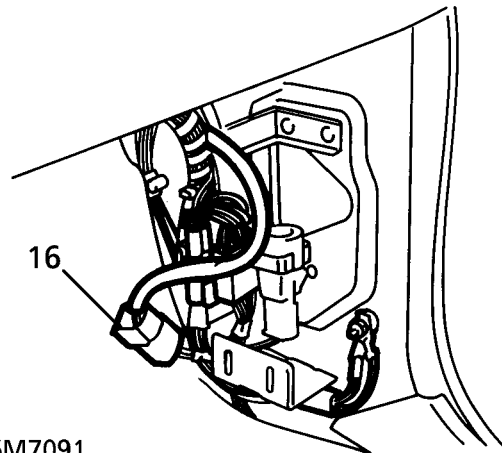

76M7091

17. Remove sound deadener pad from transmission tunnel.

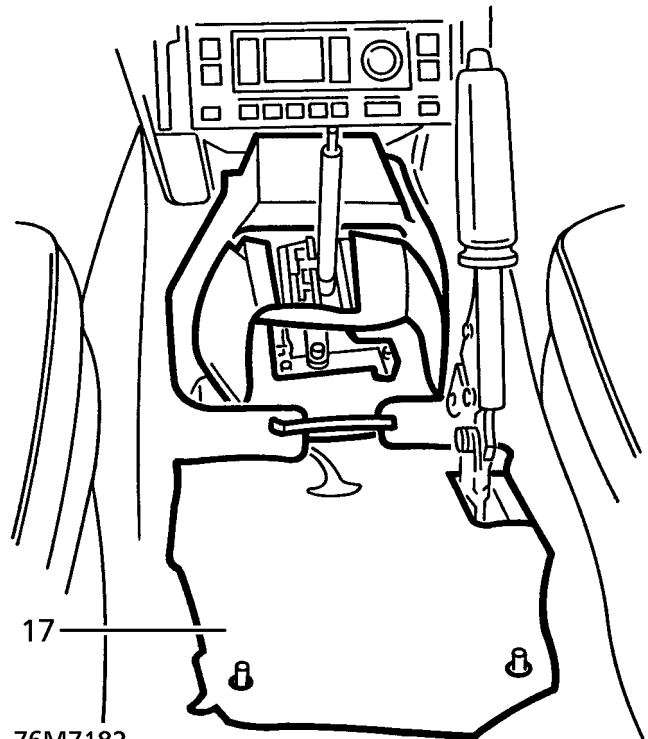

76M7182

18. Disconnect multiplug from SRS ECU. Release 3 harness clips.  
19. Remove both front wheel arch liners. **See CHASSIS AND BODY, Repair.**



- 20. Remove 2 trim studs securing air cleaner baffle beneath LH wheel arch. Remove baffle.

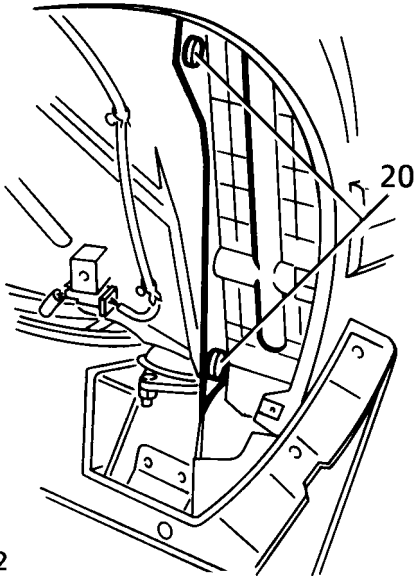

76M7092

- 21. Disconnect both SRS crash sensor multiplugs.

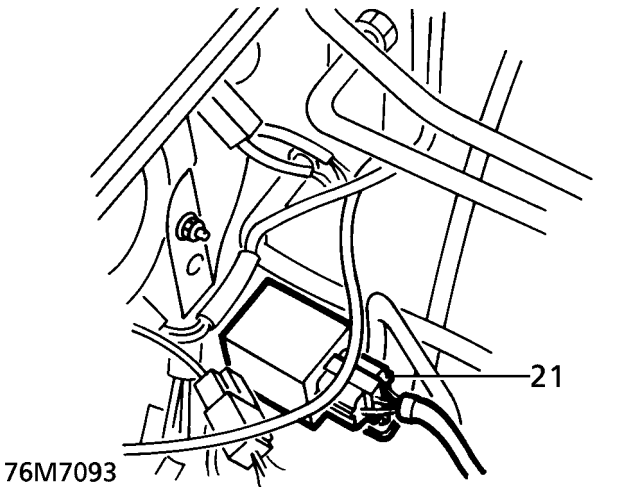
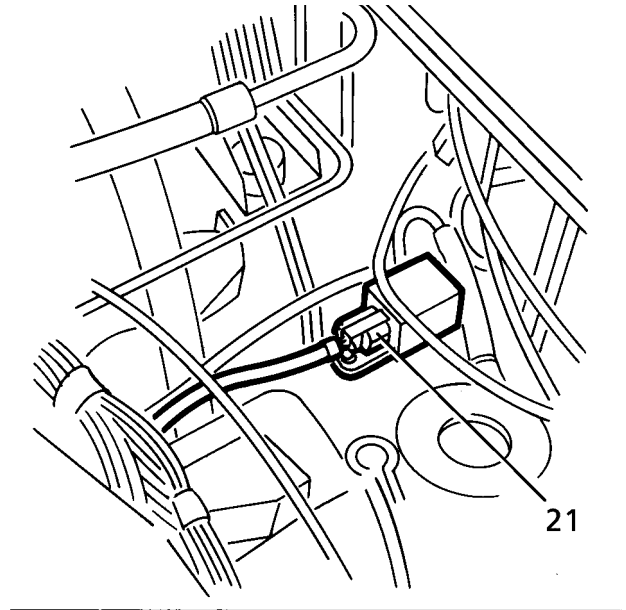

76M7093

- 22. Remove 4 bolts securing battery tray.

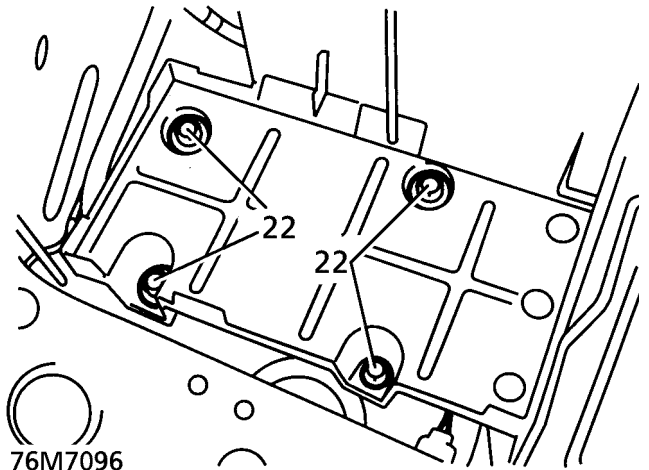

76M7096

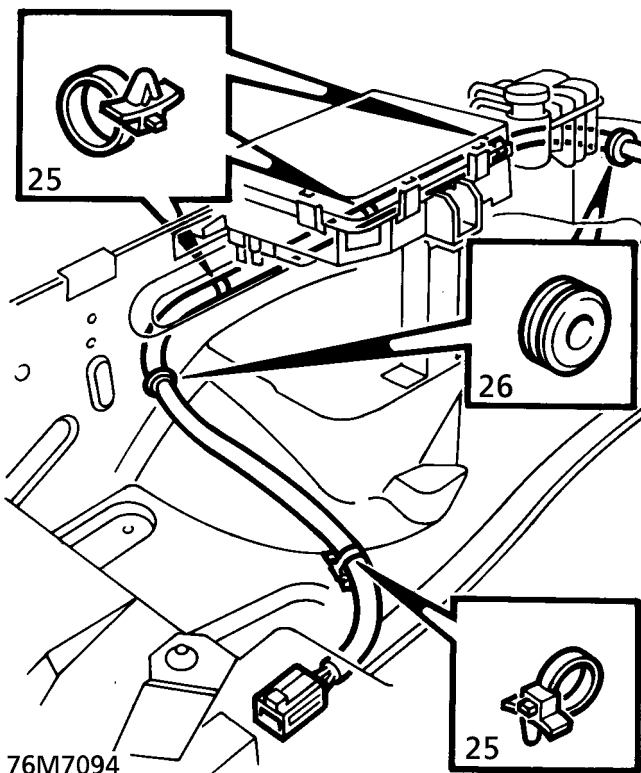
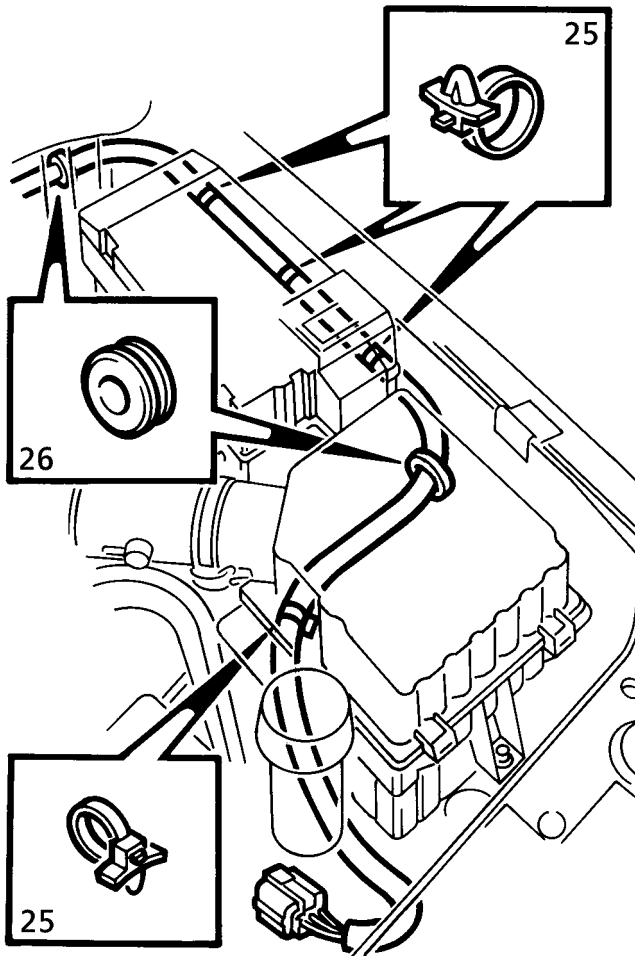

76M7094

to crash sensor harness clips.

25. Release clips securing each crash sensor harness to valance.
26. Release harness grommets. Feed both harnesses through valance into wheel arches.
27. Release 3 clips securing each crash sensor harness to underside of wheel arches.
28. Release harness bulkhead grommets. Feed harnesses through bulkhead into passenger compartment.
29. Disconnect SRS multiplug from instrument pack.

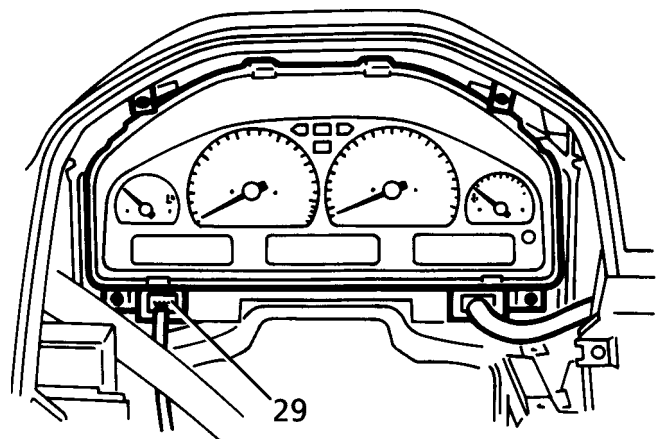

76M7095

23. Remove 2 bolts securing air cleaner to valance.
24. Raise air cleaner and battery tray to gain access

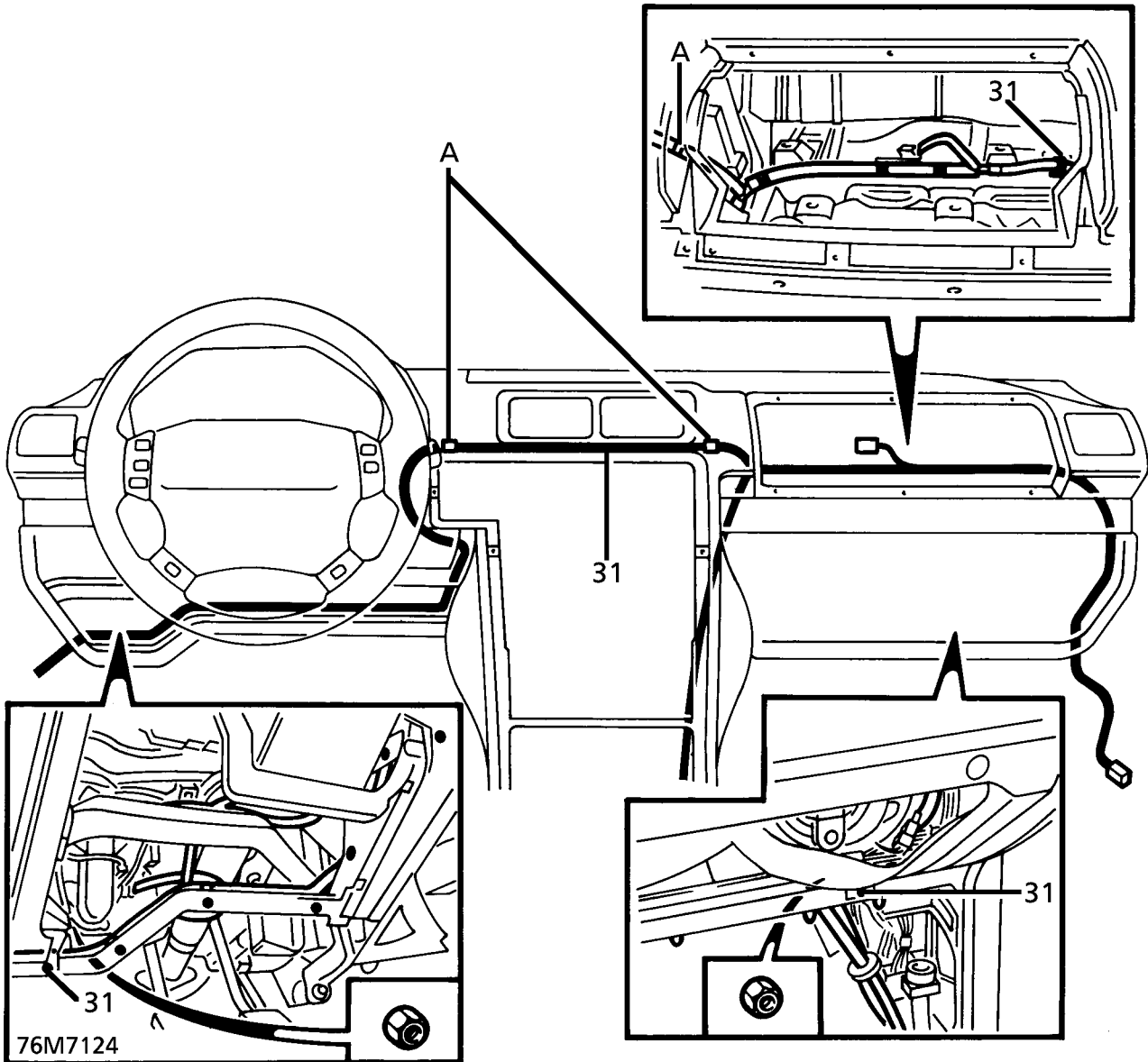

- 30. Disconnect drivers air bag module connector. Release connector and harness from clips.
- 31. Release 13 clips securing SRS harness to fascia frame.

**NOTE:** Due to restricted access, two outer clips 'A' securing harness above heater unit may have to be cut. Ensure that location holes are clear. Collect loose ends of clips.

- 32. Release 3 clips securing fascia harness trunking to passenger side fascia frame.
- 33. Remove nut securing lower end of each blower assembly to fascia frame.
- 34. Route crash sensor ends of harness into passenger air bag module space.
- 35. Feed SRS ECU connector into passenger air bag module space.
- 36. Remove harness.

**Refit**

- 37. Position harness in passenger air bag module space. Feed SRS ECU connector between heater and fascia frame.
- 38. Route harness along transmission tunnel. Secure harness clips.
- 39. Connect multiplug to ECU.
- 40. Fit sound deadener pad to transmission tunnel.
- 41. Route crash sensor ends of harness correctly around fascia frame and behind blower assemblies.
- 42. Secure harness clips to fascia frame.
- 43. Position fascia harness trunking. Secure with clips.
- 44. Secure blower assemblies to fascia frame with nuts.
- 45. Connect drivers air bag module, secure multiplug and harness to trunking.
- 46. Connect SRS multiplug to instrument pack.

47. Route SRS crash sensor harnesses through bulkhead into wheel arches, locate harness grommets.
48. Secure harness clips beneath wheel arches.
49. Route harnesses through valances into engine bay. Locate harness grommets.
50. Raise battery tray and air cleaner for access. Route crash sensor harnesses. Secure harness clips.
51. Connect multiplugs to crash sensors.
52. Secure battery tray and air cleaner with bolts.
53. Connect SRS harness multiplug to main harness. Secure multiplug to bracket.
54. Fit air cleaner baffle beneath LH wheel arch. Secure with trim studs.
55. Fit wheel arch liners. **See CHASSIS AND BODY, Repair.**
56. Position drivers side lower closing panel. Connect footwell lamp multiplug.
57. Align closing panel. Secure with scrivet fasteners.
58. Position 'A' post lower trim panels. Engage sprag clips. Secure with screws.
59. Re-fit door aperture seals.
60. **LHD automatic vehicles only:** Position foot rest. Secure with bolts.
61. Position heater controls. Connect multiplugs. Secure to fascia with screws.
62. Position fascia switch pack. Connect multiplugs. Secure to fascia with screws.
63. Fit instrument pack binnacle. **See INSTRUMENTS, Repair.**
64. Fit radio. **See ELECTRICAL, Repair.**
65. Fit passenger air bag module. **See this section.**
66. Fit centre console. **See CHASSIS AND BODY, Repair.**
67. Fit battery. **See ELECTRICAL, Repair.**
68. Remove safety stands. Lower vehicle.

## SRS CRASH SENSOR

Service repair no - 76.73.70

### Remove



**WARNING: Always disconnect negative lead from battery first. Disconnection of positive lead with negative lead connected risks short circuit and severe sparking through accidental grounding of spanner. Personal injury could result.**

1. Disconnect both battery terminals.
2. Disconnect sensor multiplug.
3. Remove 2 bolts securing sensor to valance. Remove sensor.

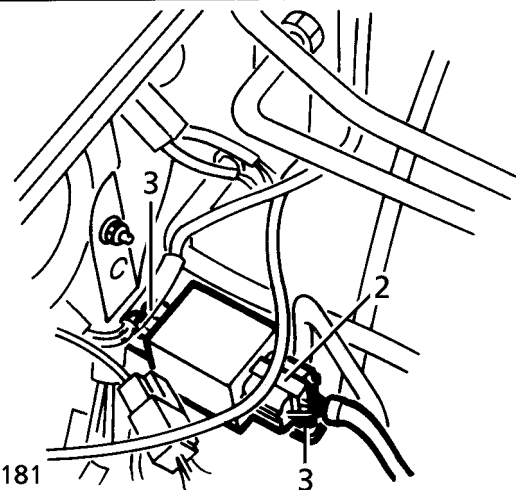
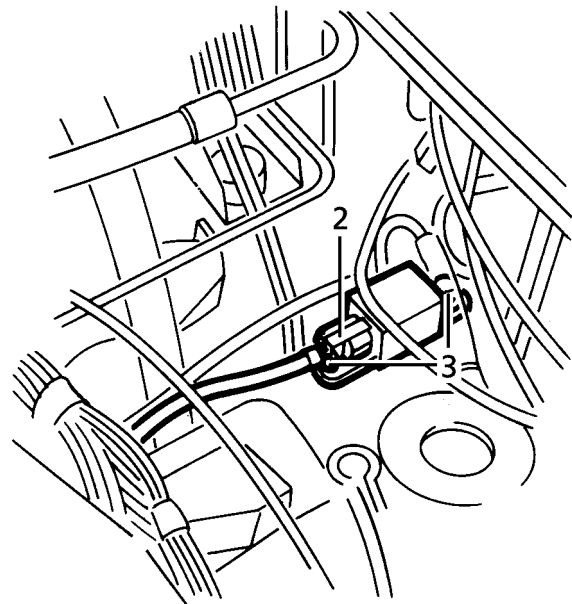

76M7181

### Refit

4. Reverse removal procedure.



**AIRBAG MODULE - DRIVER SIDE**

Service repair no - 76.73.71

**Remove**

1. Disconnect both battery terminals, negative lead first.
2. Remove steering column nacelle. **See STEERING, Repair.**
3. Disconnect Supplementary Restraint System (SRS) 'shorting link'.

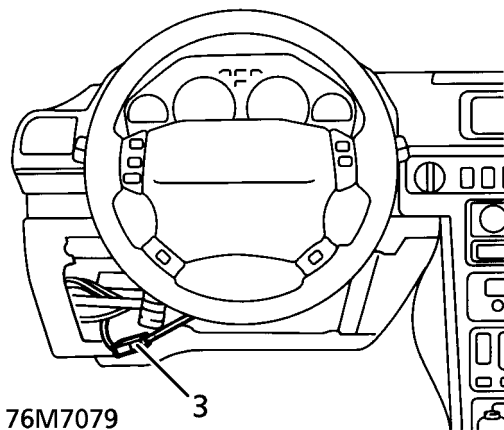

4. Unscrew 4 bolts (TX 30 Torx bit) securing module to steering wheel.

△ **NOTE: Fixings remain captive in steering wheel.**

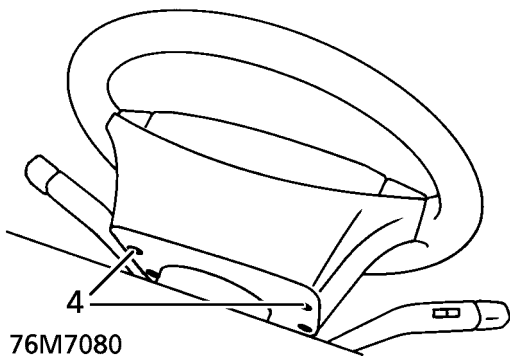

△ **NOTE: Rotate steering wheel for access to all fixings.**

5. Release module from steering wheel, disconnect multiplug.
6. Remove module.



**CAUTION: Store the airbag module correctly. See Description and operation.**

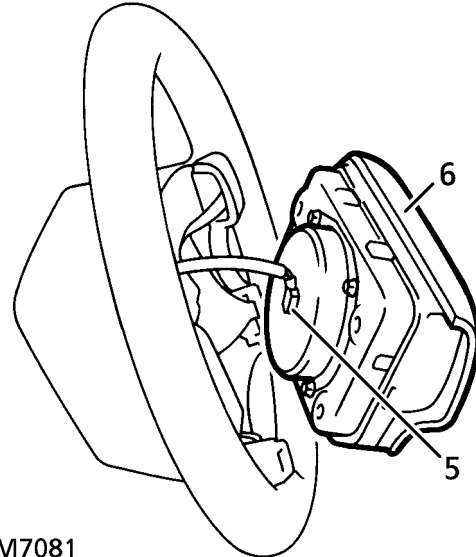

**Refit**



**NOTE: If a new airbag module is being fitted, the serial numbers must be recorded.**

7. Position module and connect multiplug.
8. Tighten bolts to **9 Nm. (7 lbf.ft)**
9. Connect SRS 'shorting link' and secure connector to location.
10. Fit steering column nacelle. **See STEERING, Repair.**
11. Connect battery terminals, positive before negative. Fit and secure battery cover.
12. Check SRS using **TestBook** .





---

**FRONT DOOR**

---

Service repair no - 76.28.07



**NOTE:** Adjustment should not be necessary unless door or hinges have been renewed.

**Alignment of door to aperture.**

1. Gain access to 'A' post hinge bolts by removing relevant wheel arch liner. **See Repair.**
2. Slacken 2 bolts securing striker to 'B/C' post.
3. Slacken 6 bolts securing door hinges to 'A' post.
4. With assistance, adjust door position in aperture. Tighten hinge bolts to **30 Nm. (22 lbf.ft)**

**Profile adjustment, door skin/frame to adjacent body panels.**

5. Slacken 4 bolts securing hinges to door.
6. With assistance adjust inboard/outboard position of door. Tighten hinge bolts to **30 Nm. (22 lbf.ft)**



**CAUTION:** Ensure that leading edge of door is flush with adjacent panels or wind noise will result.

7. When alignment of door is correct, adjust height and inboard/outboard position of striker. Tighten striker bolts. Check for correct door latching.
8. Slacken bolts and readjust striker position as necessary. Tighten striker bolts to **22 Nm. (16 lbf.ft)**
9. Fit wheel arch liner. **See Repair.**

---

**REAR DOOR**

---

Service repair no - 76.28.08



**NOTE:** Adjustment should not be necessary unless door or hinges have been renewed.

1. Open door and slacken 2 bolts securing striker to 'D' post.
2. Open front door and slacken 6 bolts securing rear door hinges to 'B/C' post.
3. With assistance, adjust door position in aperture and tighten hinge bolts to **25 Nm. (18 lbf.ft)**
4. To adjust profile of door skin and frame relative to adjacent body panels, slacken 4 bolts securing hinges to door.
5. With assistance adjust inboard/outboard position of door. Tighten hinge bolts to **25 Nm. (18 lbf.ft)**



**CAUTION:** Ensure that leading edge of door is flush with adjacent panels or wind noise will result.

6. When alignment of door is correct, adjust height and inboard/outboard position of striker. Tighten striker bolts and check for correct door latching.
7. Slacken bolts and readjust striker position as necessary. Tighten striker bolts to **22 Nm. (16 lbf.ft)**



## BONNET

Service repair no - 76.16.01

### Remove

1. Open bonnet.
2. Mark hinge outlines on bonnet.
3. Remove 2 hinge bolts from each side.

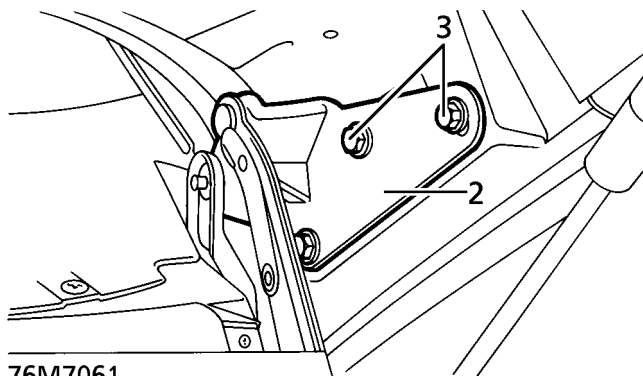

76M7061

4. Disconnect washer tube at T piece on bonnet, release tube from clip.

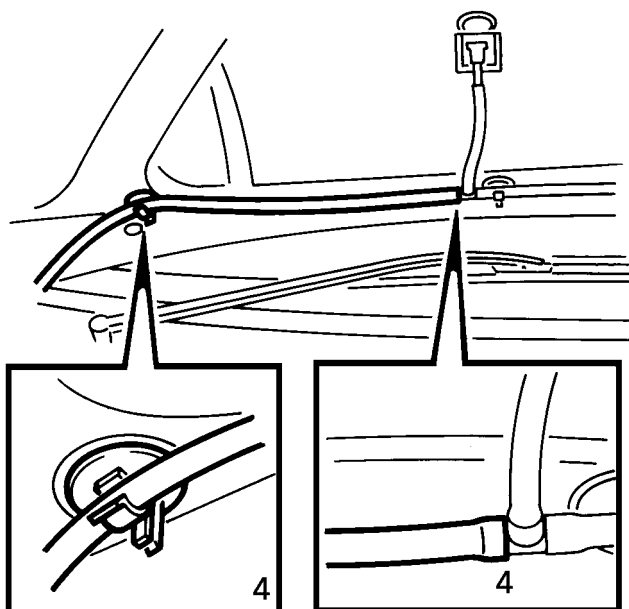

76M7062

5. With assistance, release bonnet support struts at lower ends.
6. With assistance, remove 2 remaining hinge bolts and remove bonnet.

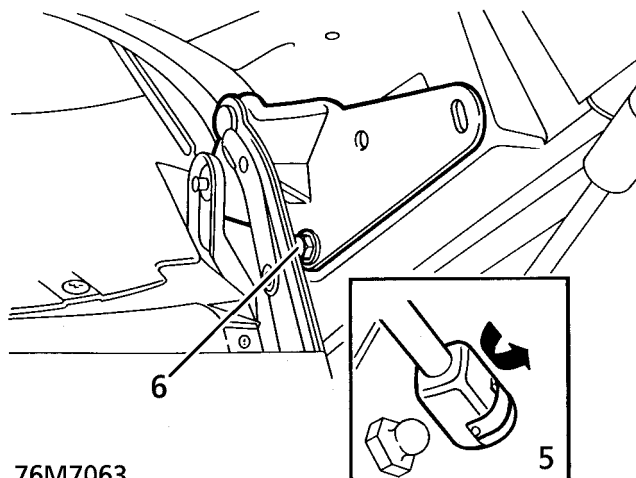

76M7063

### Refit

7. With assistance, fit bonnet. Fit, but do not tighten bolts.
8. With assistance, connect bonnet support struts.
9. Connect washer tube, secure to clip.
10. Close bonnet, check alignment.
11. Open bonnet, tighten hinge bolts.
12. Close bonnet.

**BONNET LOCK PIN**

Service repair no - 76.16.24

**Remove**

1. Remove bolts securing lock pin to bonnet.
2. Remove pin.

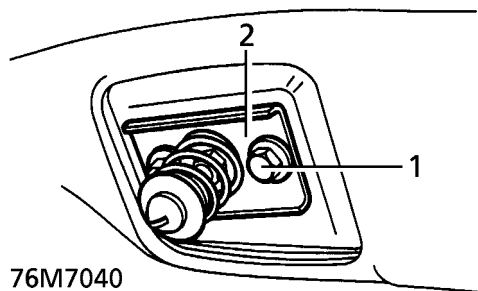
**Refit**

3. Position lock pin to bonnet.
4. Fit bolts but do not tighten.
5. Close and open bonnet to align pin.
6. Secure pin with bolts.
7. Lubricate pin.

**BONNET LOCK - LEFT HAND**

Service repair no - 76.16.21

**Remove**

1. Remove bolts securing bonnet lock.

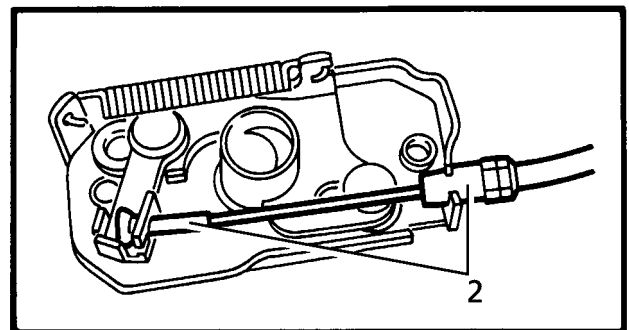
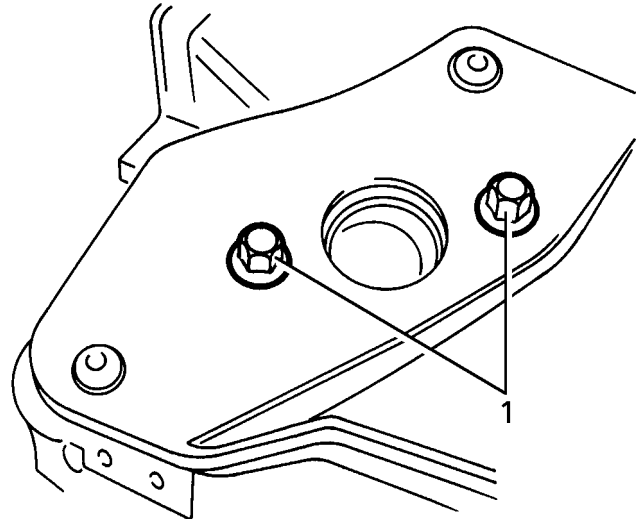

76M7118

2. Release outer and inner cables from lock.
3. Remove lock.

**Refit**

4. Reverse removal procedure.



## BONNET LOCK - RIGHT HAND

Service repair no - 76.16.25

### Remove

1. Release 3 turnbuckles securing battery cover.  
Remove cover

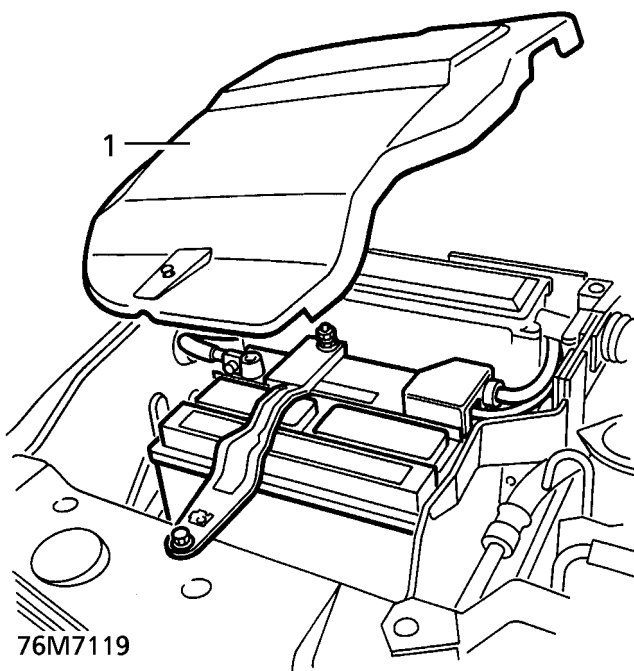

2. Remove 2 bolts securing bonnet lock to platform.

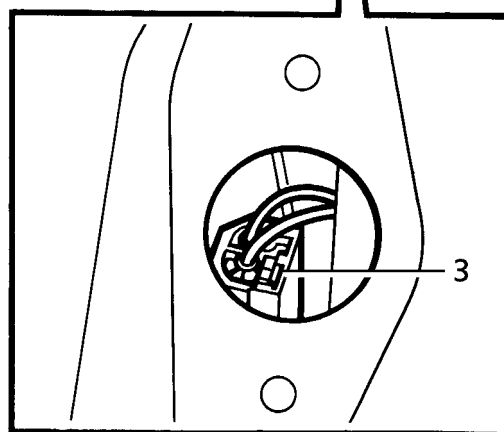
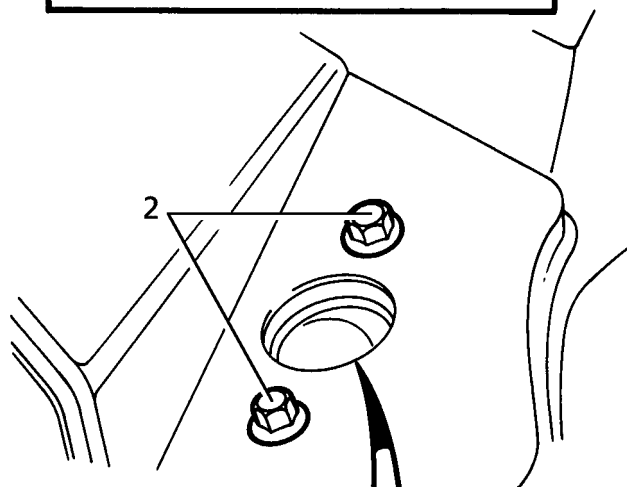
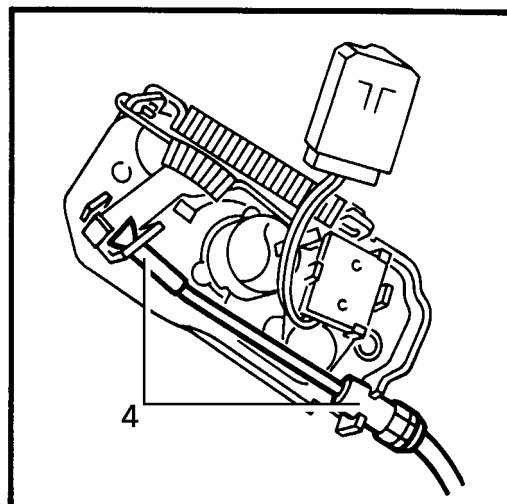

3. Manoeuvre lock and disconnect alarm switch multiplug.
4. Release inner and outer cables from lock.
5. Remove lock.

### Refit

6. Reverse removal procedure.

**BONNET SAFETY CATCH**

Service repair no - 76.16.34

**Remove**

1. Remove bolts securing safety catch to bonnet.
2. Remove safety catch.

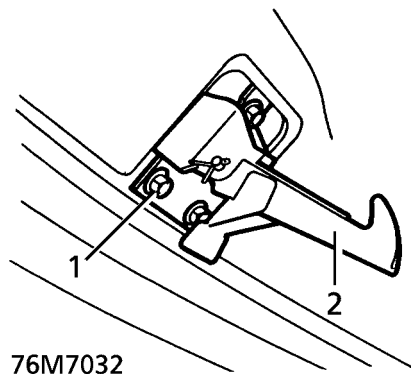
**Refit**

3. Position catch to bonnet.
4. Fit bolts, do not tighten.
5. Close and open bonnet to align catch.
6. Secure catch with bolts.

**BONNET STRUT**

Service repair no - 76.16.14

**Remove**

1. Support bonnet in open position.
2. Release clip securing strut lower ball joint.

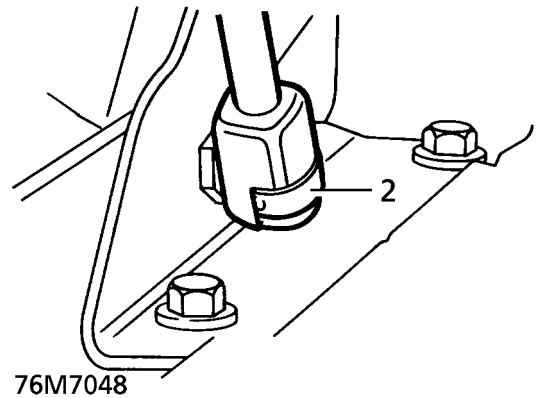

3. Remove screws securing strut bracket to bonnet.
4. Remove strut and bracket.

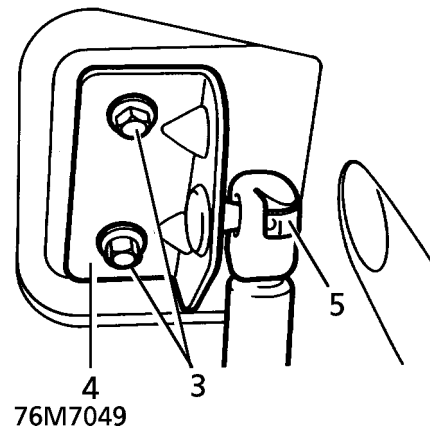

5. Remove strut from bracket.

**Refit**

6. Fit strut to bonnet bracket, fit to bonnet.
7. Secure strut to lower ball joint.
8. Fit bracket screws. Remove support, close bonnet.



## CENTRE CONSOLE

Service repair no - 76.25.01

### Remove

1. Remove electric window switch pack. **See ELECTRICAL, Repair.**
2. Disconnect rear footwell lamp multiplug.
3. Remove base in console bin.

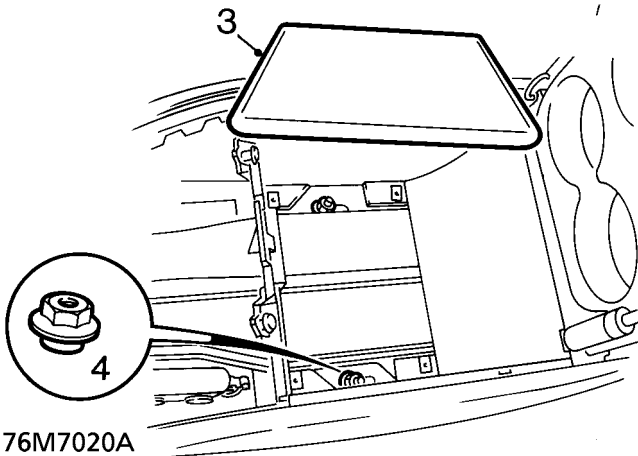

76M7020A

4. Remove nuts securing rear of console to floor studs.
5. Move both front seats fully rearward.
6. Remove 2 screws securing each side panel to centre console. Release sprag clips from fascia switch pack by firmly pulling rearwards. Remove side panels.

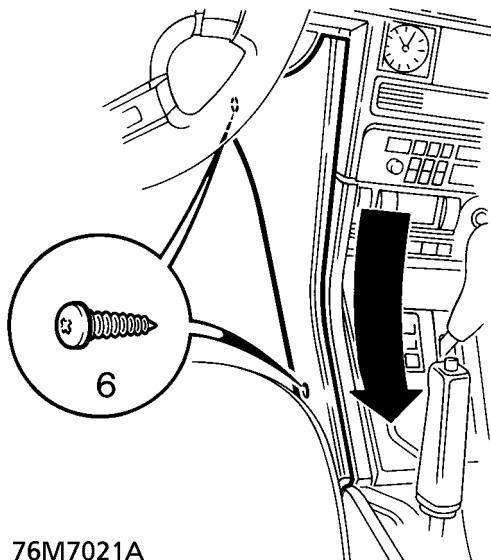

76M7021A

7. Remove screw at rear of gear lever applique. Raise rear end of applique to disengage 2 spring clips at forward end.

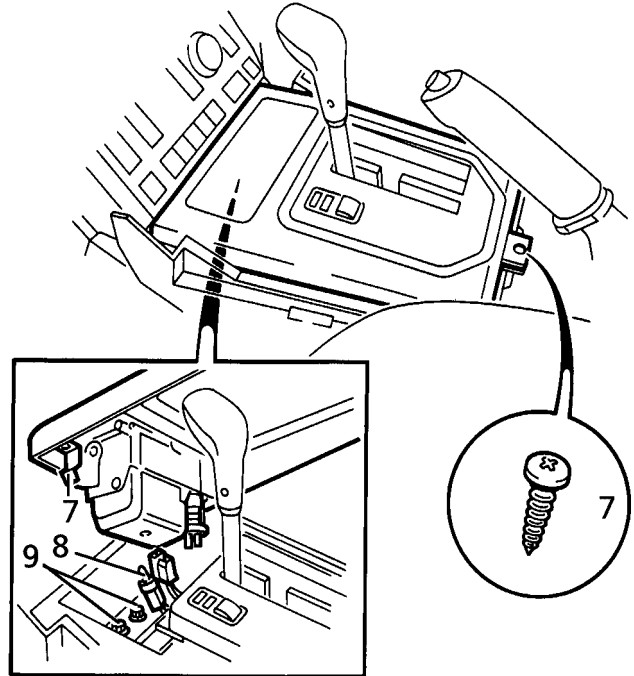

76M7022

8. Disconnect cigar lighter multiplug, release cigar lighter bulb. Remove gear lever applique.
9. **Manual gearbox models:** Remove gear knob. Remove 2 bolts securing front of console to floor.
10. **Automatic gearbox models:** Remove 2 screws securing selector lever.
11. Remove selector lever.

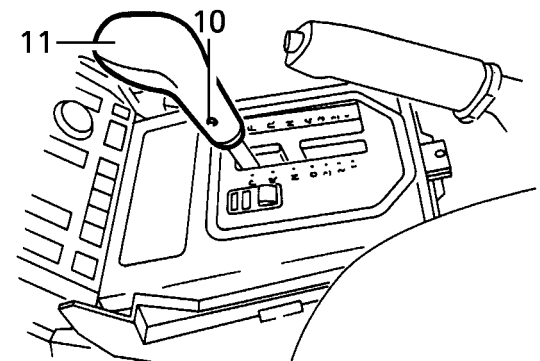

76M7023

12. Remove 3 screws securing selector graphics plate.
13. Raise selector graphics plate, disconnect multiplug.

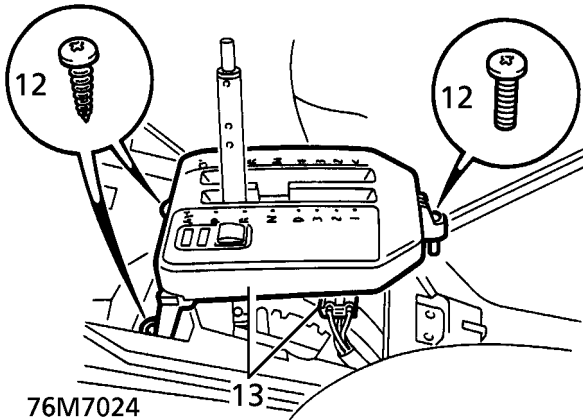

76M7024

14. Remove selector graphics plate.
15. **All models:**  
Remove clip securing park brake lever clevis pin, remove clevis pin. Raise park brake lever to vertical position.

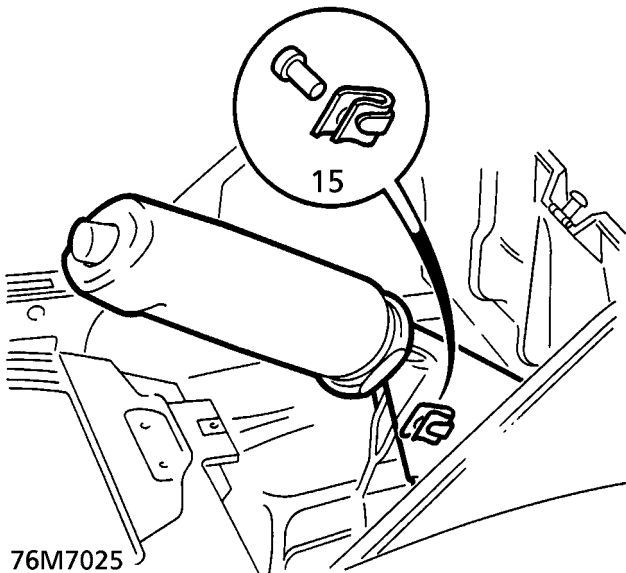

76M7025

16. Raise rear of console to disengage rear vent ducts. Remove centre console.

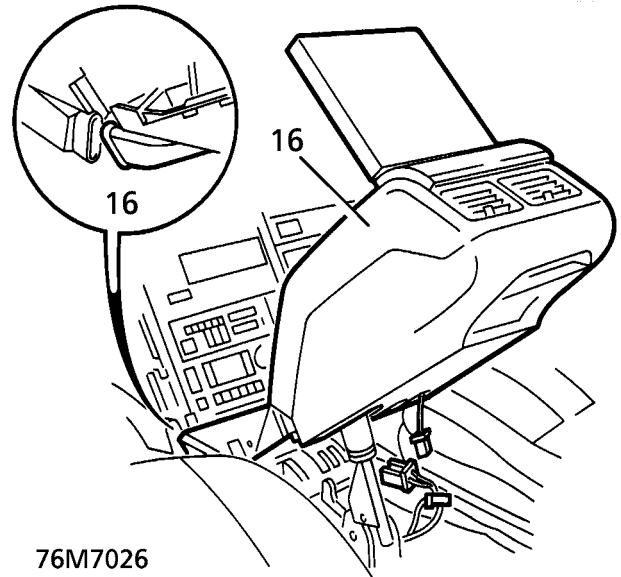

76M7026

### Refit

17. Fit centre console, ensuring that ducts to rear fresh air vents are correctly engaged.
18. Fit nuts securing centre console to floor.
19. Automatic - position graphics plate over selector lever, connect multiplug.
20. Align graphics plate to console, secure with screws.
21. Fit selector lever, secure with screws.
22. Manual - secure front of centre console to floor with bolts.
23. Fit gear knob.
24. Lower park brake lever, fit clevis pin and secure pin with clip.
25. Position gear/selector lever applique, connect cigar lighter multiplug and insert illumination bulb in holder.
26. Engage applique clips to console. Secure applique with screw.
27. Position console side panels. Firmly push forward to engage sprag clips into fascia switch pack. Fit and tighten screws.
28. Return front seats to original positions.
29. Fit base to console bin, tighten with screws.
30. Connect rear footwell lamp multiplug.
31. Fit electric window switch pack. **See ELECTRICAL, Repair.**



## CHASSIS CROSS MEMBER

### Remove

1. Disconnect battery negative lead.
2. Raise vehicle on four post lift.
3. Support transmission with a suitable stand.
4. Remove and discard 6 nuts securing transmission mount to crossmember. Remove snubber bar.
5. Remove 3 of 4 nuts and bolts securing each side of crossmember to chassis.

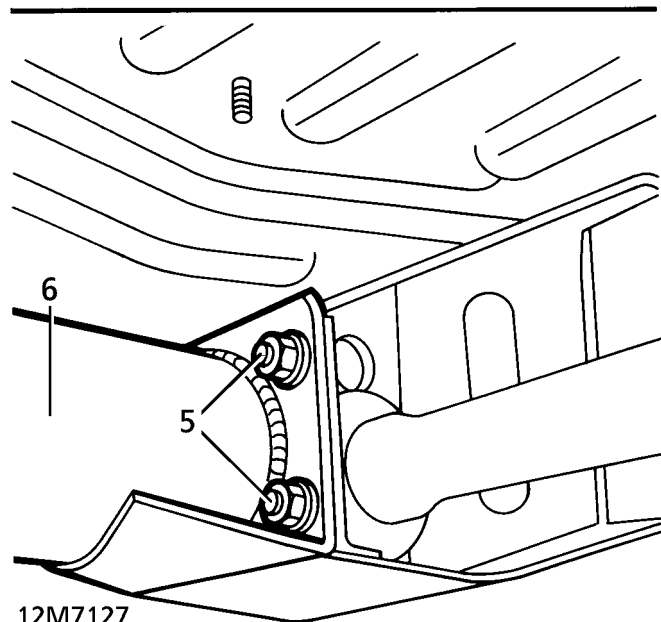
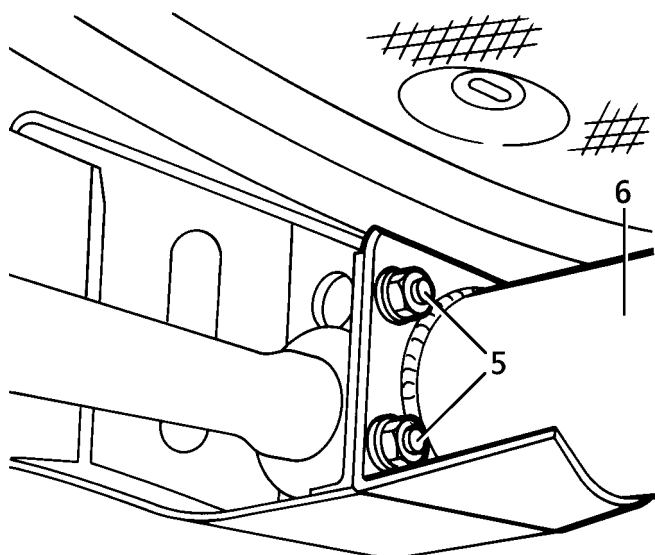

12M7127

6. With assistance, remove remaining bolt securing crossmember. Remove crossmember.

### Refit

7. With assistance, position crossmember to chassis. Secure with nuts and bolts. Tighten to **45 Nm. (33 lbf.ft)**
8. Fit snubber bar. Secure transmission mount to crossmember with new flange nuts. Tighten to **45 Nm. (33 lbf.ft)**
9. Remove support from transmission.
10. Lower vehicle.
11. Reconnect battery negative lead.



**ENGINE ACOUSTIC COVER**

Service repair no - 76.11.06

**Remove**

1. Raise front of vehicle.

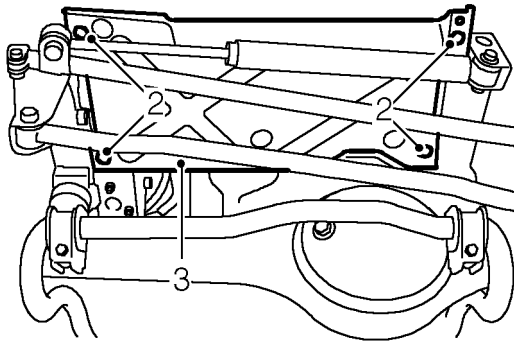
**WARNING: Support on safety stands.**

76M7237

2. Release 4 threaded fasteners securing engine acoustic cover to chassis brackets.
3. Release acoustic cover from brackets and manoeuvre past steering gear.

**Refit**

4. Fit acoustic cover to brackets and secure with threaded fasteners.

**GEARBOX LOWER ACOUSTIC COVER**

Service repair no - 76.11.13

**Remove**

1. Raise front of vehicle.

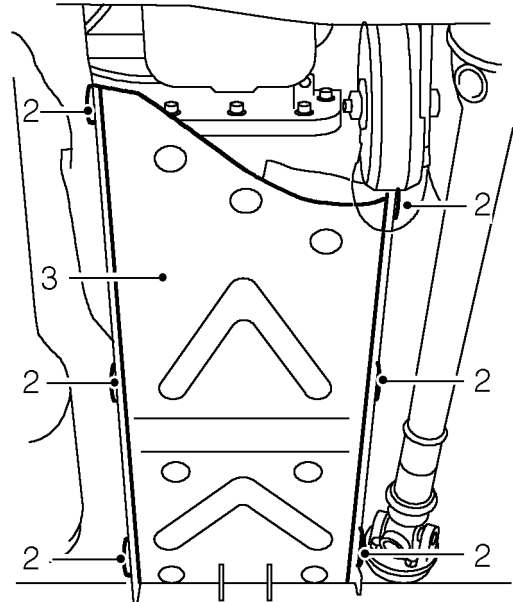
**WARNING: Support on safety stands.**

76M7238

2. Release 6 threaded fasteners securing lower acoustic cover to side acoustic covers.
3. Remove lower acoustic cover.

**Refit**

4. Fit acoustic cover to side acoustic covers.
5. Tighten threaded fasteners securing lower cover to side covers.
6. Remove stand(s) and lower vehicle.



### GEARBOX ACOUSTIC COVER - RH

Service repair no - 76.11.14

#### Remove

1. Raise front of vehicle.



**WARNING: Support on safety stands.**

2. Remove gearbox lower acoustic cover. **See this section.**

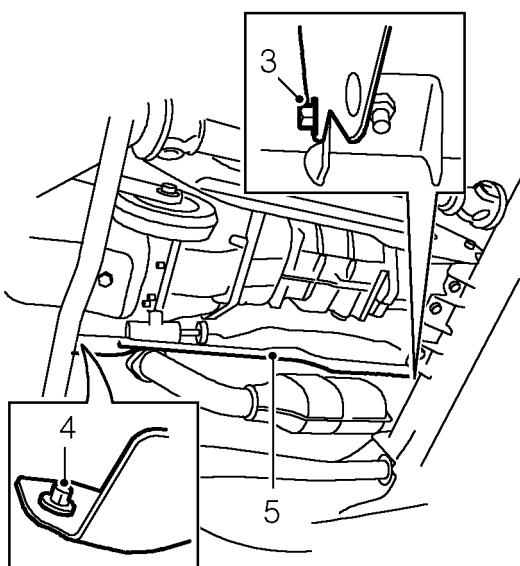

76M7240

3. Remove bolt securing RH acoustic cover to crossmember.
4. Remove bolt securing RH acoustic cover to chassis member.
5. Remove gearbox RH acoustic cover.

#### Refit

6. Fit acoustic cover to chassis and secure with bolts.
7. Fit gearbox lower acoustic cover. **See this section.**

### GEARBOX ACOUSTIC COVER - LH

Service repair no - 76.11.15

#### Remove

1. Raise front of vehicle.



**WARNING: Support on safety stands.**

2. Remove gearbox lower acoustic cover. **See this section.**

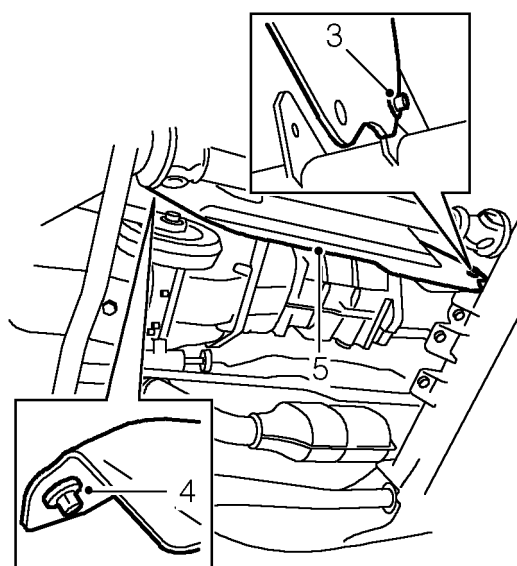

76M7239

3. Remove bolt securing LH acoustic cover to crossmember.
4. Remove bolt securing LH acoustic cover to chassis member.
5. Remove gearbox LH acoustic cover.

#### Refit

6. Fit acoustic cover to chassis and secure with bolts.
7. Fit gearbox lower acoustic cover. **See this section.**

## FRONT BUMPER VALANCE

Service repair no - 76.22.72

## Remove

1. Raise the vehicle.

**WARNING: Support on safety stands.**

2. Remove battery cover for access to RH fog lamp.

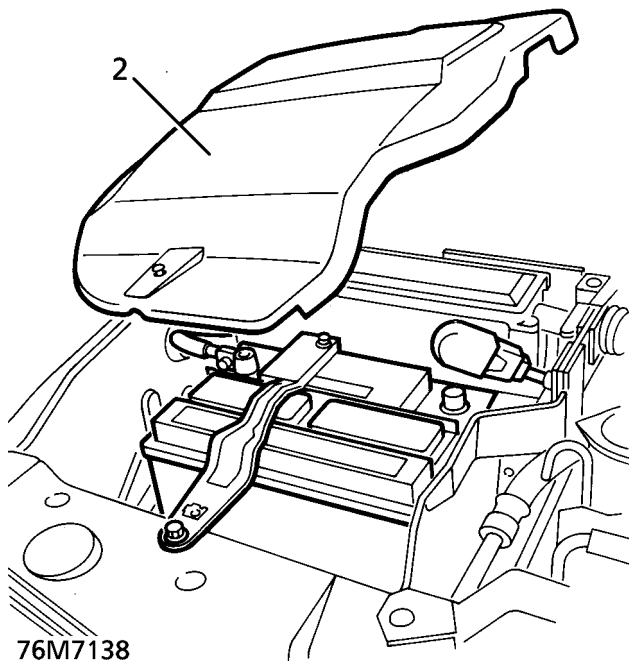

3. Disconnect fog lamp multiplugs and breather hoses.

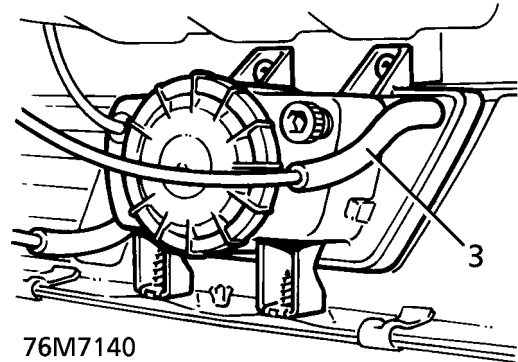
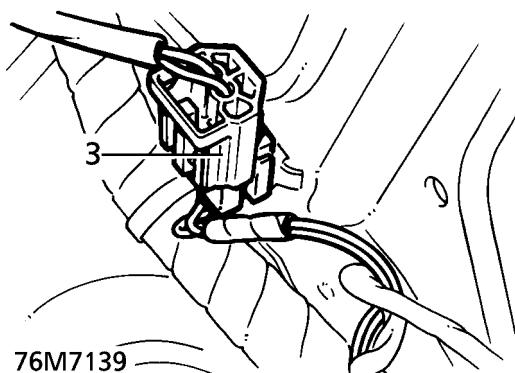

4. Release 2 clips securing bumper ends to mounting brackets.

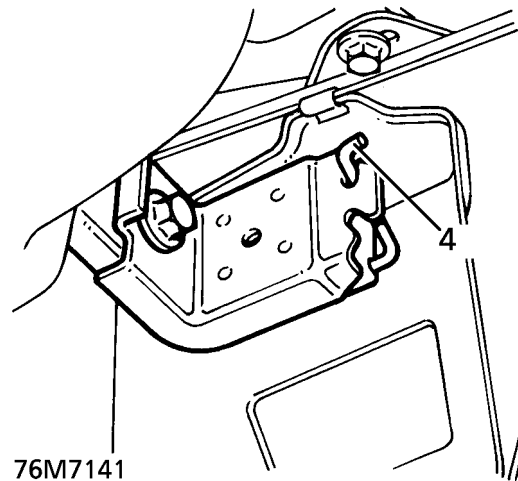

**CAUTION:** Loosen bolts securing bumper end mounting brackets to chassis frame to avoid damage to sealing rubber during bumper remove and refit.



- Remove 2 bumper bolt access plugs from bumper valance. Remove bolts.

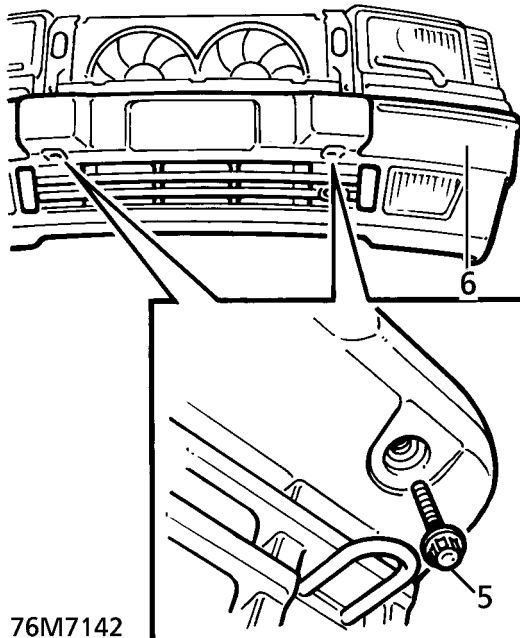

- With assistance remove bumper assembly. **Do not carry out further dismantling if component is removed for access only.**
- Remove 8 studs and 6 clips securing extensions spoiler. Remove extension.

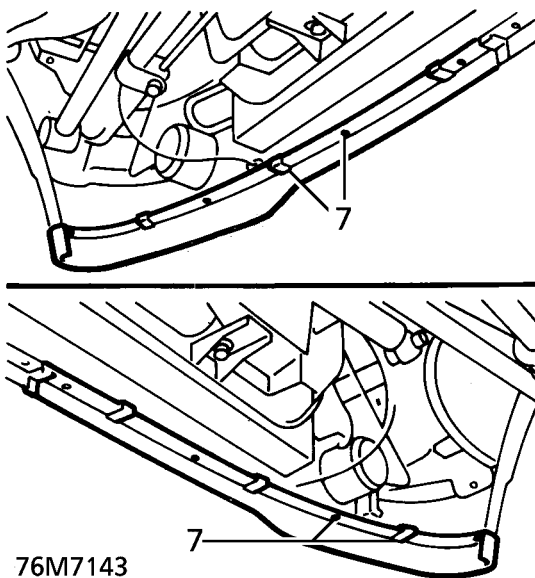

- Remove 8 screws securing fog lamps. Remove lamps.

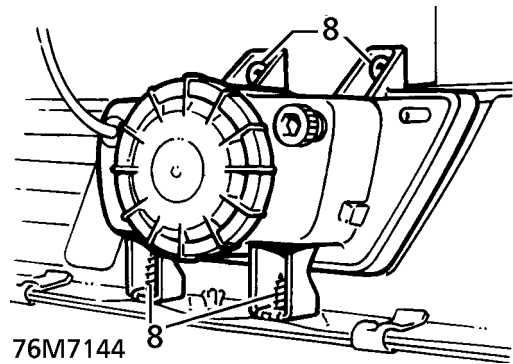

- Remove 8 bolts securing bumper end brackets to bumper. Remove brackets.

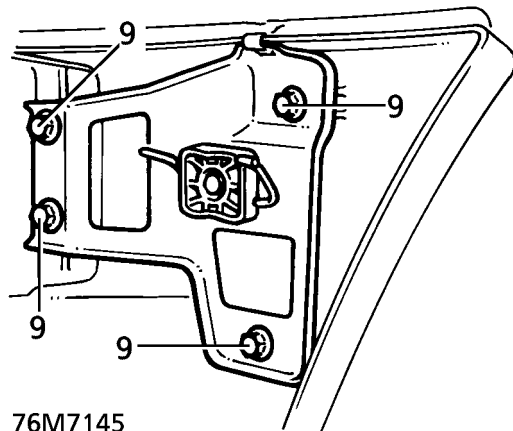

**WARNING:** If front bumper is damaged due to impact, the impact cans must be inspected. There must be no visible deformation. The overall length must be 188.25 mm  $\pm$  0.5 mm. Replace the impact cans if necessary.

Refit

- Fit end brackets and secure with bolts. Fit fog lamps and secure with screws.
- Fit extension and secure with clips and studs.
- With assistance fit bumper assembly, tighten bolts to **70Nm. (52 lbf.ft)**
- Fit bolt access plugs.
- Align end brackets, tighten bolts and secure bumper end clips.
- Connect fog lamp multiplugs and breather hoses, fit battery cover.
- Remove safety stands. Lower vehicle.

**EXTENSION SPOILER FRONT BUMPER**

Service repair no - 76.22.78

**Remove**

1. Raise the vehicle.

**WARNING: Support on safety stands.**

2. Remove 8 studs and 6 clips securing spoiler to front bumper.
3. Remove spoiler halves.

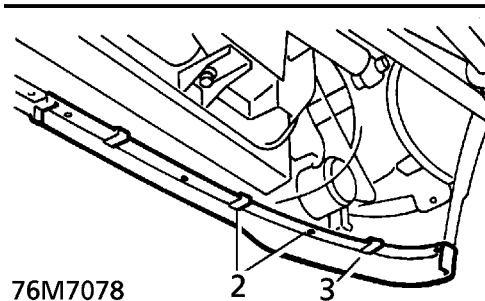
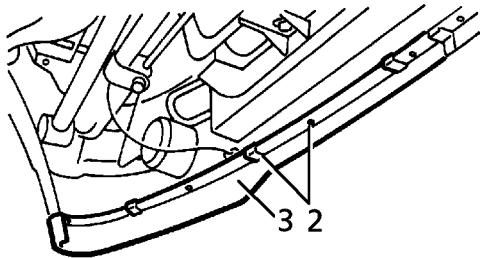

76M7078

**Refit**

4. Fit spoiler halves to bumper. Secure with clips and studs.
5. Remove safety stands. Lower vehicle.

**REAR BUMPER VALANCE**

Service repair no - 76.22.74

**Remove**

1. Raise the vehicle.

**WARNING: Support on safety stands.**

2. Remove rear road wheels.
3. Remove 3 screws securing each mud flap. Remove mud flaps.
4. Remove 2 screws securing each wheel arch liner extension panel to rear bumper/chassis.
5. Remove 2 wheel arch liner extension panels.
6. Release 2 clips securing bumper ends to mounting brackets.

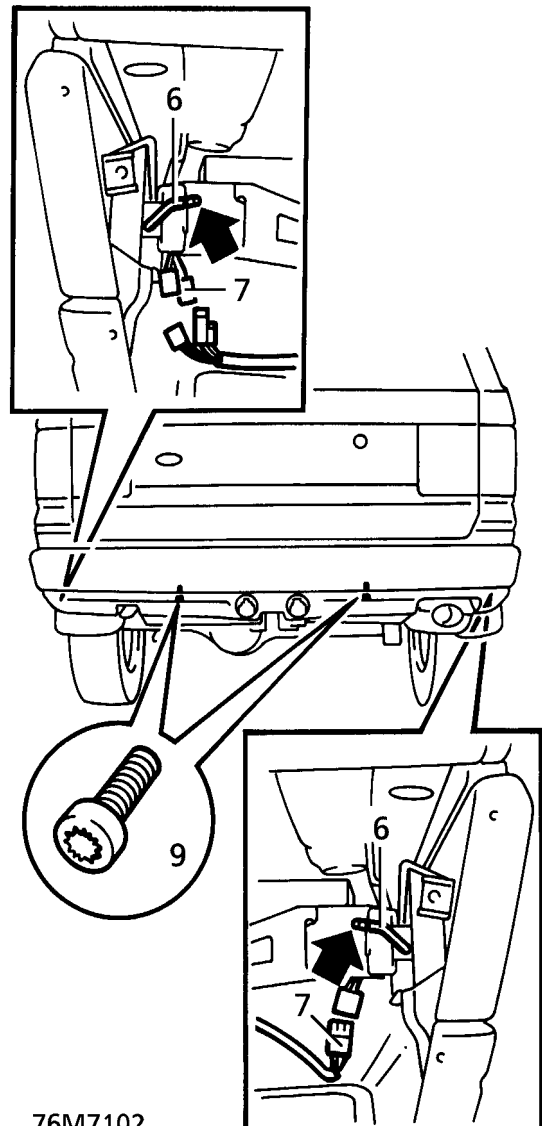

76M7102



7. Disconnect 3 towing harness multiplugs.
8. Remove 2 mounting bolt covers.
9. Remove 2 bolts securing bumper to chassis.
10. With assistance, release bumper ends from brackets. Remove bumper.

#### Refit

11. With assistance, position bumper. Engage nylon end supports to brackets.
12. If necessary, slacken bolts securing end support brackets. Align bumper to body. Tighten to **29 Nm. (22 lbf.ft)**
13. Fit bumper mounting bolts. Tighten to **70 Nm. (52 lbf.ft)**
14. Fit bolt covers.
15. Secure bumper end clips.
16. Connect towing harness multiplugs.
17. Position wheel arch liner extensions. Secure with screws.
18. Position mud flaps. Secure with screws.
19. Fit road wheels. Tighten to **108 Nm. (80 lbf.ft)**
20. Remove safety stands. Lower vehicle.

#### FASCIA ASSEMBLY

Service repair no - 76.46.23/99



**WARNING:** The fascia assembly houses the heater distribution unit, blower assemblies and air conditioning evaporator. Assistance is essential during removal and refit procedures.



**CAUTION:** When removed from the vehicle, the fascia should be placed on a soft covered work surface, supported on suitable wooden blocks.

#### Remove

1. **Vehicles with SRS only:** Remove battery. **See ELECTRICAL, Repair.**
2. **Vehicles without SRS:** Disconnect battery negative lead.
3. Drain cooling system. **See COOLING SYSTEM, Repair.**
4. Loosen hose clips, disconnect hoses from heater pipes.

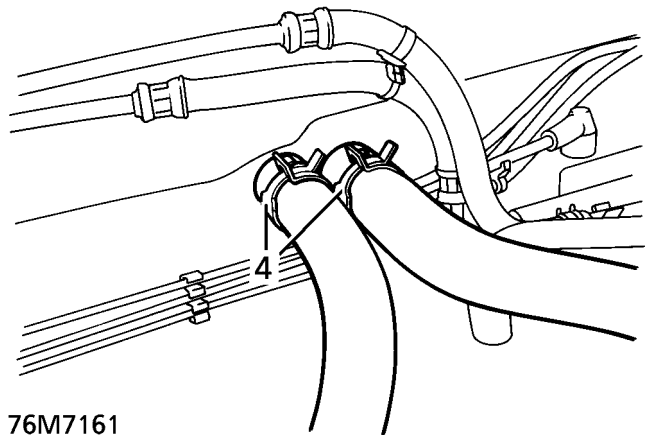

76M7161

5. Remove centre console. **See this section.**
6. Remove steering column. **See STEERING, Repair.**
7. Remove wiper motor and linkage. **See WIPERS AND WASHERS, Repair.**
8. Disconnect passenger side heated front screen multiplug. Release multiplug from clip.

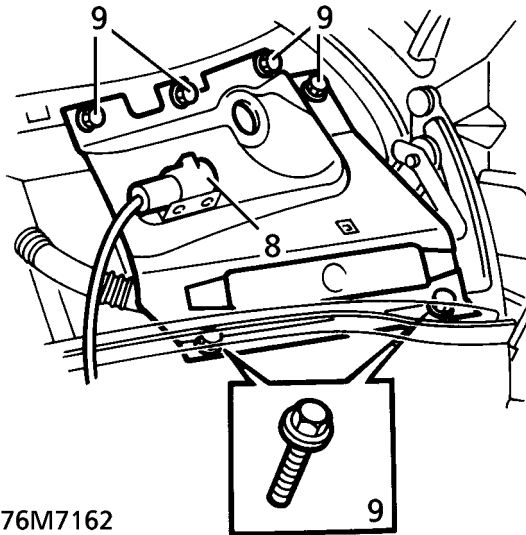

76M7162

9. Remove 6 bolts, remove remaining scuttle side panel.
10. Remove heater intake pollen filters.
11. Remove 8 screws securing each pollen filter housing. Remove both housings.

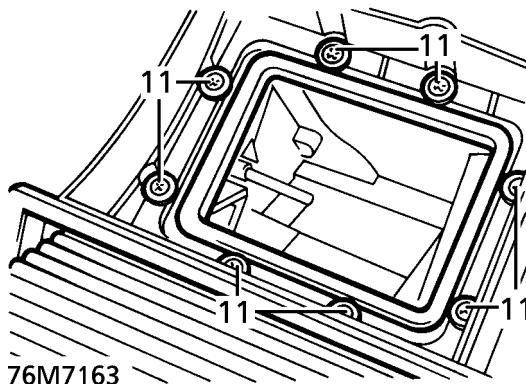

76M7163

12. Remove radio. *See ELECTRICAL, Repair.*
13. Release door aperture seal adjacent to 'A' post lower trim panels.

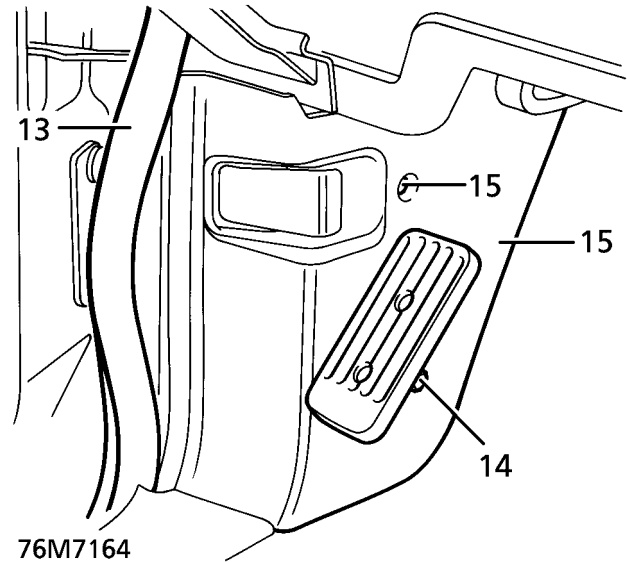

76M7164

14. **Driver's side - LHD automatic vehicles only:** Remove 3 bolts securing foot rest through 'A' post lower trim, remove foot rest.
15. Remove screw securing each 'A' post lower trim panel, release from single sprag clip, remove both trim panels.

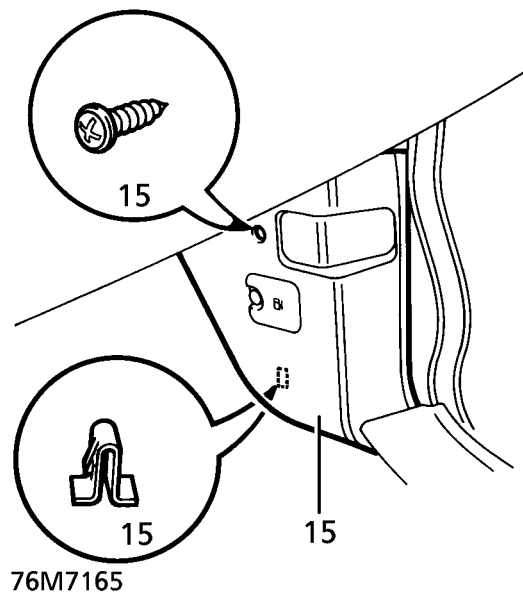

76M7165



16. Remove fuse cover from driver's seat base trim.

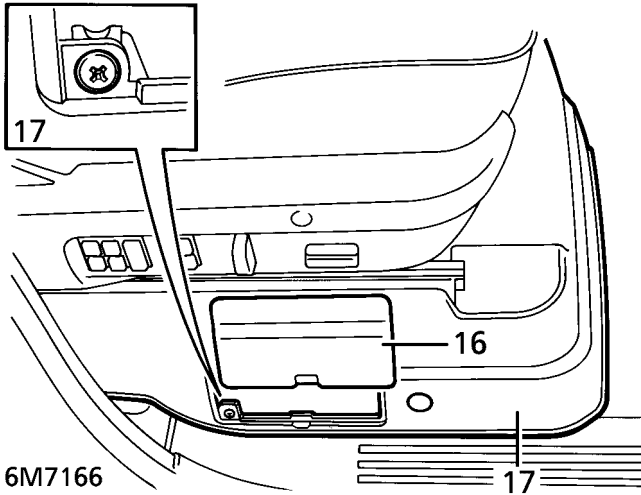

19. Remove 2 scrivet fasteners securing lower closing panel to passenger side of fascia.

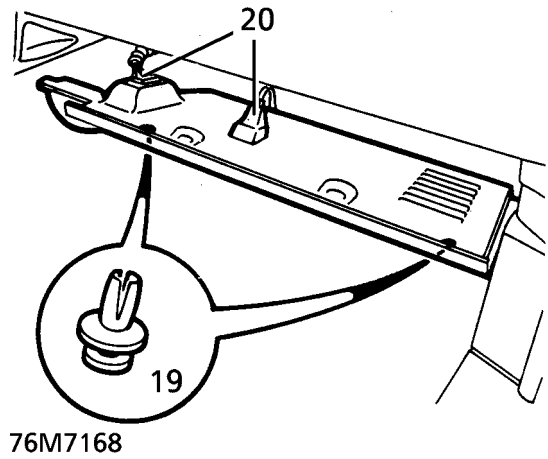

17. Remove screw and 2 trim studs, remove seat base trim.

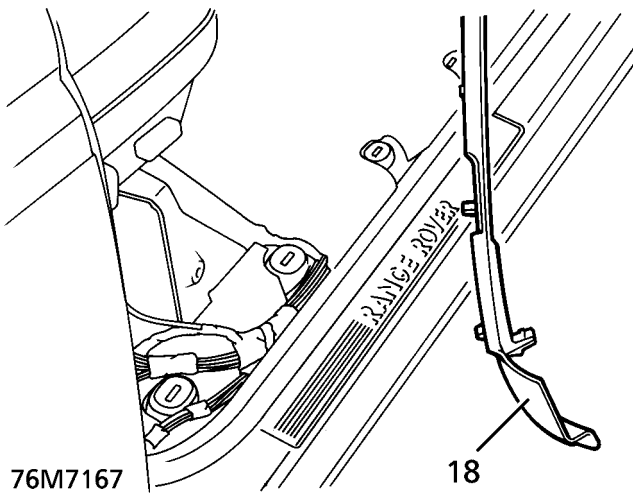

20. Release closing panel, disconnect footwell lamp, release diagnostic multiplug. Remove closing panel.

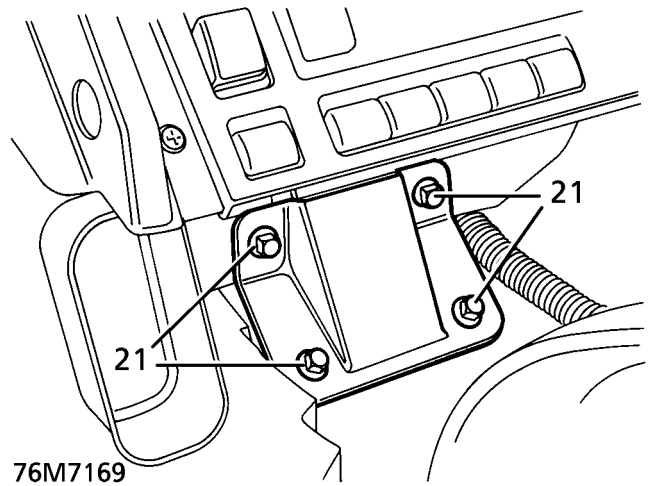

18. Release 4 sprag clips, remove driver's side carpet retainer.

21. Remove 4 bolts, remove fascia centre bracket.



22. Disconnect 4 multiplugs from Body Electrical Control Module (BeCM)

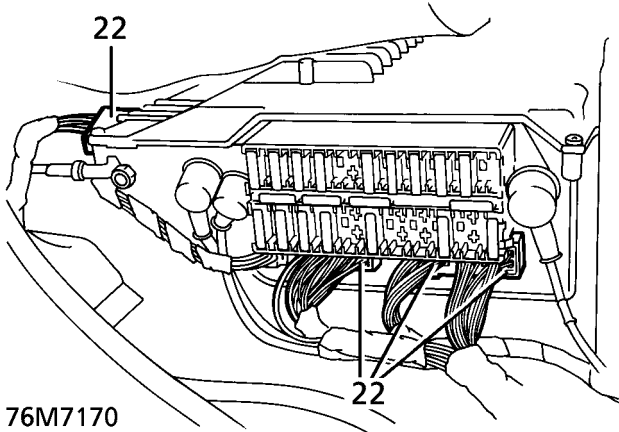

25. Release BeCM harness from sill, route into fascia to prevent fouling as fascia is removed.

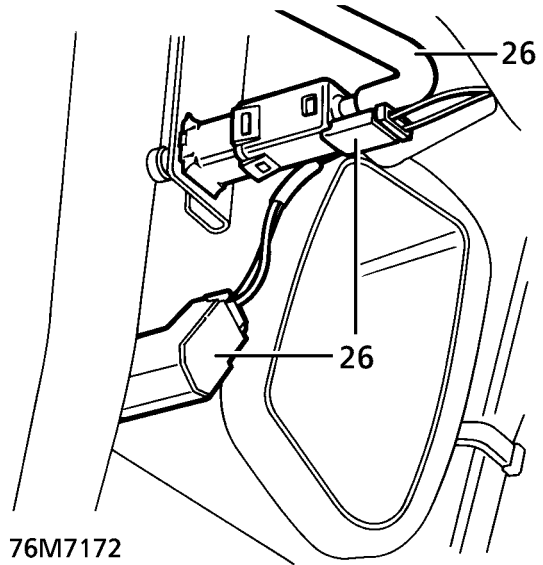

23. Remove captive nut, remove earth wires from stud at base of driver's side 'A' post.

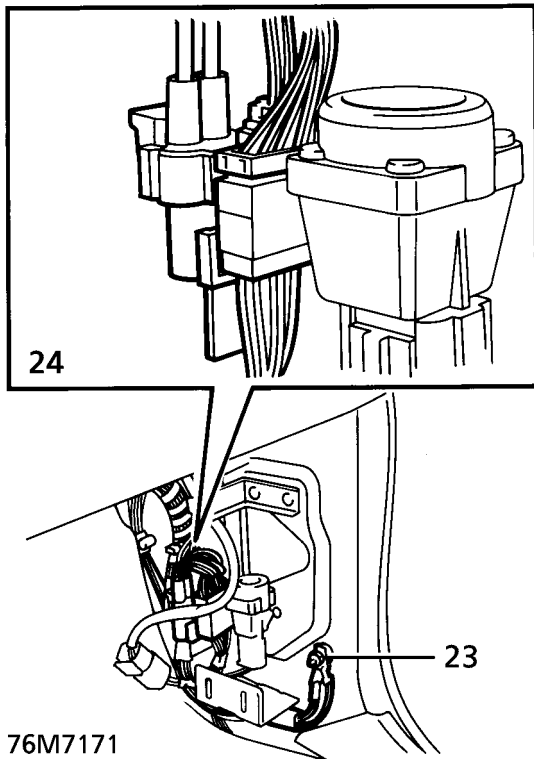

26. Disconnect multiplugs and release vacuum hose from brake and clutch switches.

27. **Models with SRS only:** Disconnect SRS multiplug from main harness.

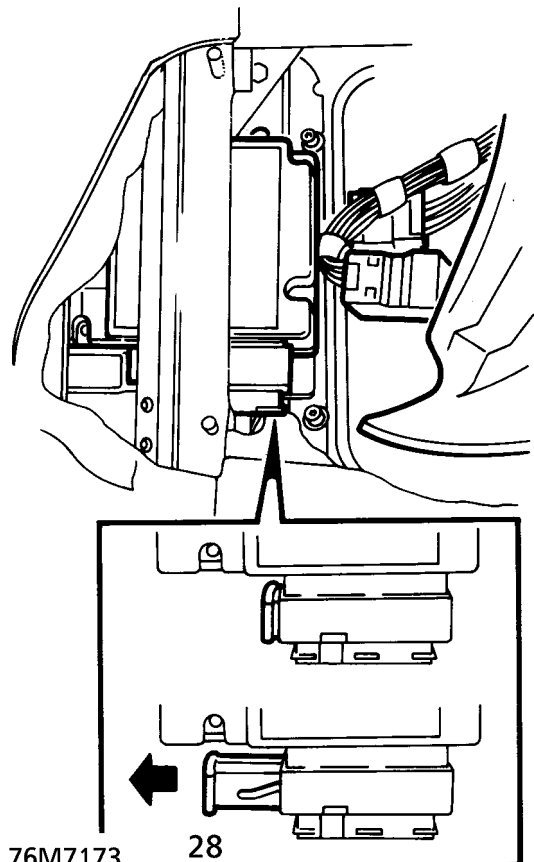

24. Disconnect multiplugs at base of each 'A' post.



- 28. Disconnect multiplug from SRS control module, route harness into fascia to prevent fouling as fascia is removed.
- 29. Remove both front wheel arch liners. **See this section.**

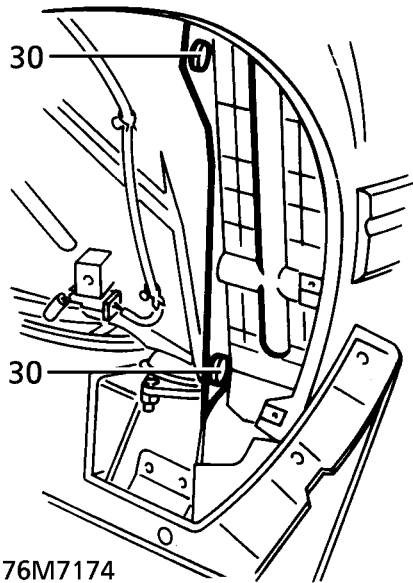

- 30. Remove 2 scrivet fasteners securing air cleaner baffle beneath LH wheel arch. Remove baffle.

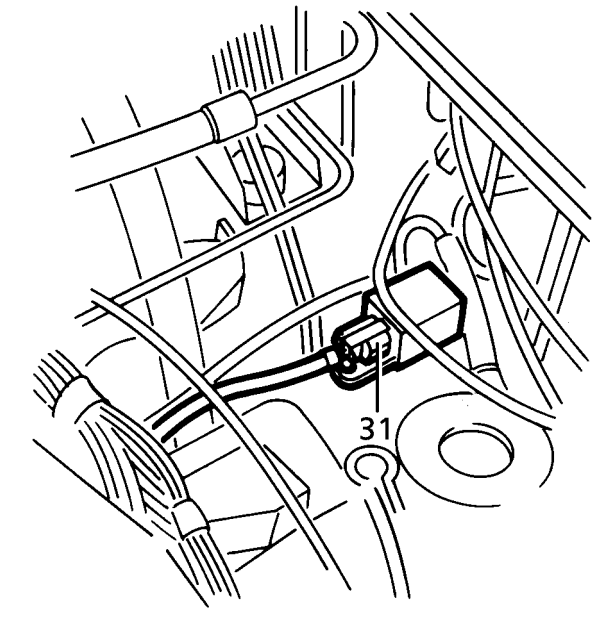

76M7175

- 31. Disconnect both SRS crash sensor multiplugs.

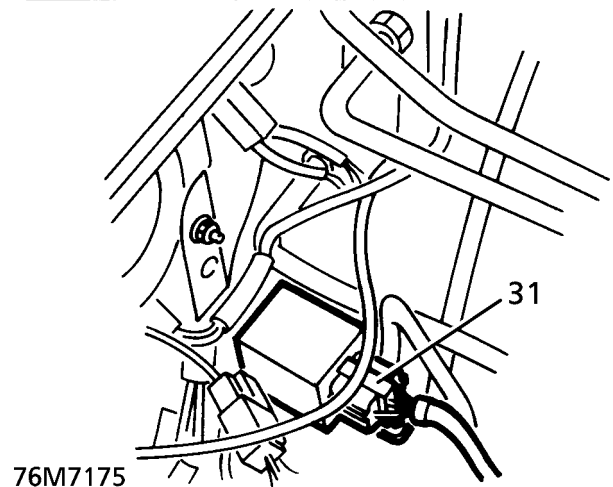

76M7176

- 32. Remove 4 bolts securing battery tray and 2 bolts securing air cleaner to valance.

33. Raise air cleaner and battery tray for access to crash sensor harness clips.

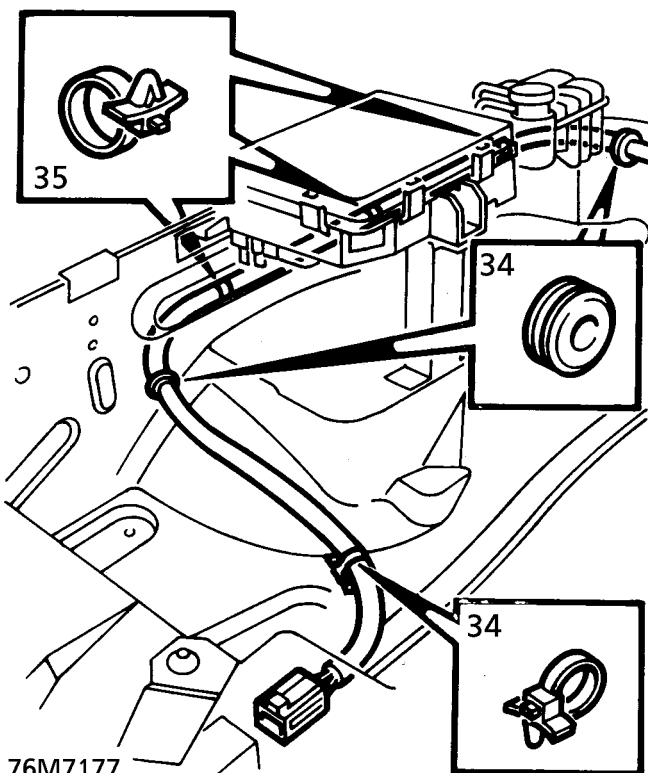
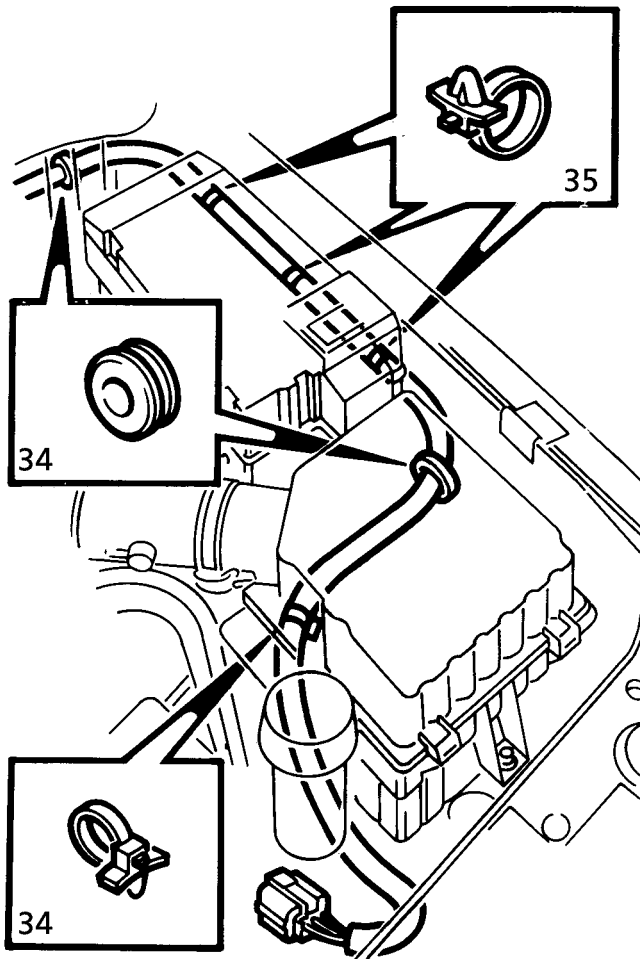

76M7177

34. Release clips securing each crash sensor harness to valance. Release harness grommets and feed both harnesses through valance into wheel arches.
35. Release 3 clips securing each crash sensor harness to underside of wheel arches.
36. Release harness grommets, feed harnesses through bulkhead and route into fascia to prevent fouling as fascia is removed.
37. **Vehicles with air conditioning only:** Discharge air conditioning system. **See AIR CONDITIONING, Adjustment.**

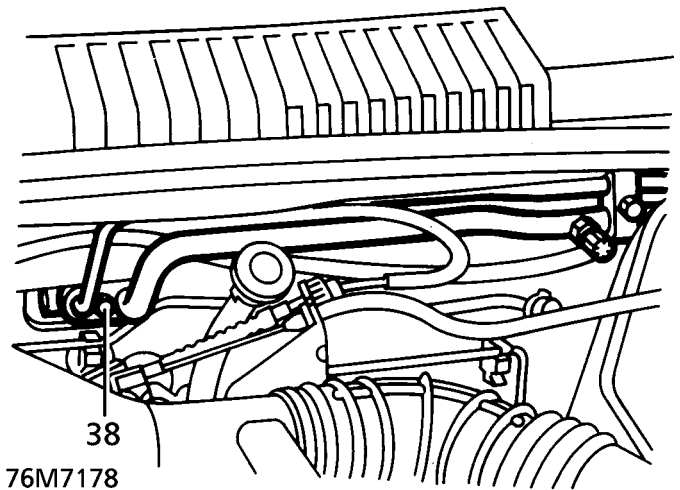

76M7178

38. Remove bolt securing pipe clamp to Thermostatic Expansion Valve (TXV).
39. Release pipes from TXV and remove 'O' rings. Seal pipes and ports of TXV.

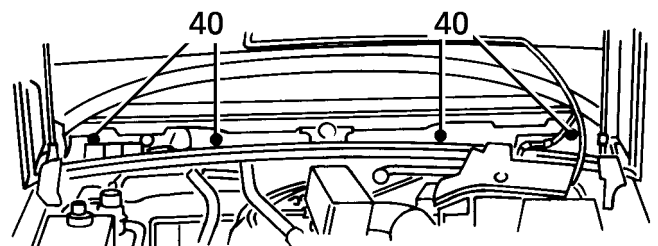

76M7179

40. **All models:** Remove 4 tube bolts securing fascia to scuttle panel.



41. Remove nuts and washers securing fascia to base of 'A' posts.

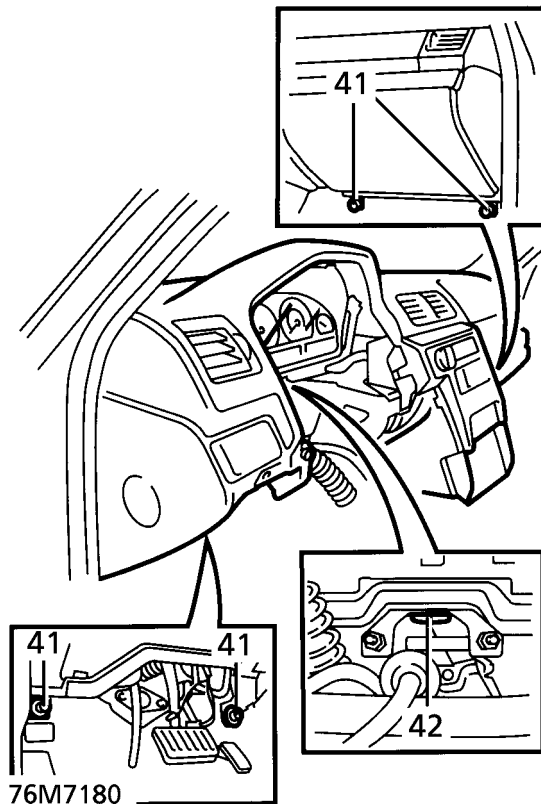

76M7180

42. Remove bolt securing fascia to pedal box.  
 43. Using assistance, carefully manoeuvre the fascia through the driver's door aperture. Place fascia on a soft covered work surface, supported on suitable wooden blocks.  
 44. Remove rubber seals from air intake ducts.  
 45. Collect rear heater duct connecting tubes.

#### Refit

46. Fit intake seals to blower motor ducts. Tape rubbers inside blower ducts to aid fitment.



**NOTE: Tape the rubbers at this stage, as they are almost impossible to locate after dash fitment.**

47. Fit guide pins LRT-76-001 to outer fascia studs.  
 48. With assistance, manoeuvre fascia into position through driver's front door aperture. Locate guide pins.



**NOTE: Assistance from a third person may be necessary when guiding heater pipes through bulkead.**

49. Loosely fit 1 tube bolt, fascia to scuttle.

50. Fit bolt securing fascia to pedal box. Tighten to **25 Nm. (18 lbf.ft)**  
 51. Fit nuts and washers at base of A posts. Tighten to **25 Nm. (18 lbf.ft)**  
 52. Remove guide pins.  
 53. Fit remaining tube bolts. Tighten to **25 Nm. (18 lbf.ft)**  
 54. Fit rear heater duct connecting pipes.  
 55. Remove tape from intake seals.  
 56. Engage lips of sealing rubbers around scuttle apertures.  
 57. Fit pollen filter housings, tighten bolts.  
 58. Fit scuttle side panel to passenger side of vehicle, tighten bolts.  
 59. Connect heated screen multiplug, fit to side panel clip.  
 60. Connect hoses to heater pipes. Tighten clips.  
 61. **Air conditioning vehicles:** Remove seals from air conditioning pipes and TXV ports.  
 62. Lubricate new O rings with clean compressor oil, fit to pipes.  
 63. Locate pipes in TXV ports, position clamp and fit clamp bolt.  
 64. Engage evaporator drain tubes over pipes in transmission tunnel.  
 65. **Vehicles with SRS only:** Route SRS crash sensor harnesses through bulkhead into wheel arches, locate harness grommets.  
 66. Secure harness clips beneath wheel arches, route harnesses through valances into engine bay, locate harness grommets.  
 67. Raise battery tray and air cleaner for access. Route crash sensor harnesses, secure harness clips, connect multiplugs to crash sensors.  
 68. Tighten battery tray and air cleaner bolts.  
 69. Connect multiplug to SRS control module.  
 70. Connect SRS harness multiplug to main harness.  
 71. Fit air cleaner baffle beneath LH wheel arch, secure with scrivet fasteners.  
 72. Fit wheel arch liners. **See this section.**  
 73. **All models:** Route harness along sill, connect multiplugs to BeCM.  
 74. Connect multiplugs at base of 'A' posts and secure plugs to brackets.  
 75. Fit earth wires to stud, tighten captive nut.  
 76. Connect vacuum hose and multiplugs to brake and clutch pedal switches.  
 77. Position closing panel beneath passenger side of fascia. Secure diagnostic plug, connect footwell lamp. Align closing panel, secure with scrivet fasteners.  
 78. Fit carpet retainer, engage sprag clips.  
 79. Fit seat base trim panel, secure trim studs, tighten screw.  
 80. Fit fuse cover to seat base trim.  
 81. Fit both 'A' post lower trim panels, secure sprag clips. Engage door aperture seals.

82. **LHD automatic vehicles only:** Fit foot rest, secure with bolts.
83. Fit radio. *See ELECTRICAL, Repair.*
84. Fit wiper motor and linkage. *See WIPERS AND WASHERS, Repair.*
85. Fit steering column. *See STEERING, Repair.*
86. Fit centre console. *See this section.*
87. Refill cooling system. *See COOLING SYSTEM, Repair.*
88. **Vehicles with SRS only:** Fit battery. *See ELECTRICAL, Repair.*
89. Reconnect battery negative lead.
90. Evacuate and recharge air conditioning. *See AIR CONDITIONING, Adjustment.*

### FASCIA ASSEMBLY - VEHICLES WITH SINGLE POINT SENSED SRS

Service repair no - 76.46.23/99



**WARNING:** Refer to SRS safety precautions before commencing repair.



**WARNING:** The fascia assembly houses the heater distribution unit, blower assemblies and air conditioning evaporator and is therefore heavy. Assistance is essential during removal and refit procedures.



**CAUTION:** When removed from the vehicle, the fascia should be placed on a work surface with a soft covering and supported on suitable wooden blocks.

#### Remove

1. Remove key from starter switch and wait 10 minutes for SRS back up power circuit to discharge.
2. Disconnect both battery terminals, earth lead first.
3. Drain cooling system. *See COOLING SYSTEM, Repair.*

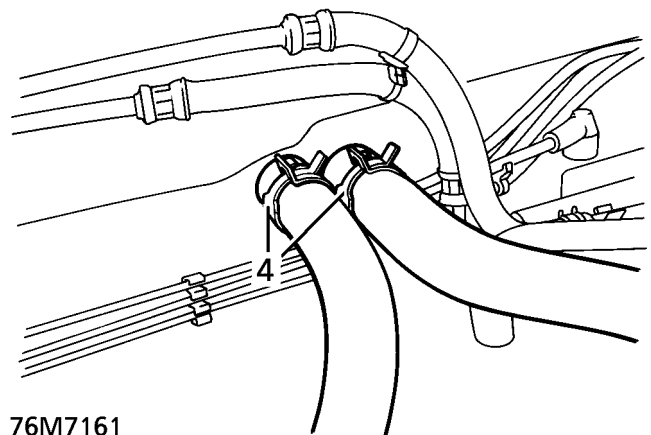

76M7161

4. Release 2 clips securing heater hoses to heater matrix and disconnect hoses.
5. Cap both heater matrix pipes to prevent coolant spillage inside vehicle during fascia removal.
6. Recover refrigerant from air conditioning system. *See AIR CONDITIONING, Adjustment.*

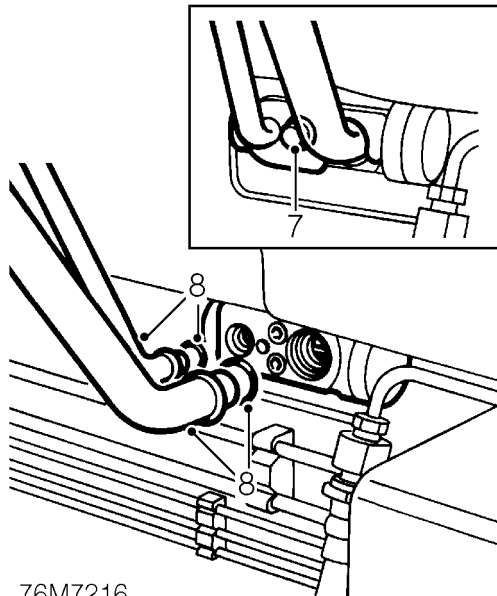

76M7216

7. Remove bolt securing pipe clamp to thermostatic expansion valve (TXV) and release pipes.
8. Remove and discard 'O' ring seals from air conditioning pipes.
9. Immediately cap both air conditioning pipes and TXV ports to prevent moisture entering the air conditioning system.
10. Remove wiper motor and linkage. **See WIPERS AND WASHERS, Repair.**

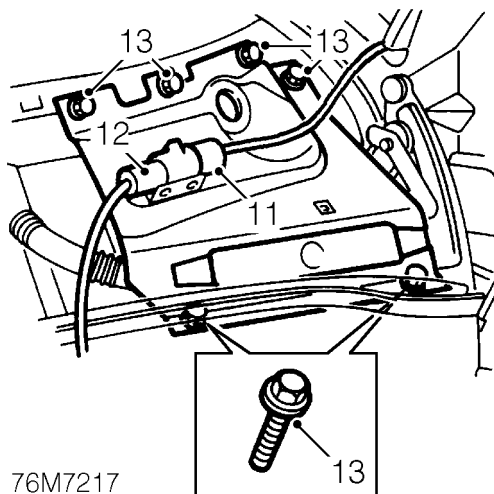

76M7217

11. Disconnect passenger side heated screen multiplug.
12. Release heated screen multiplug from scuttle side panel and position aside.
13. Remove 6 bolts securing scuttle side panel to scuttle and remove panel.

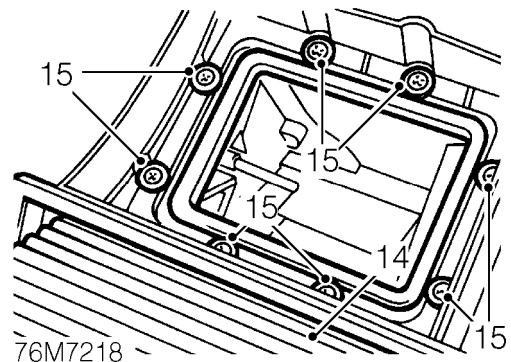

76M7218

14. Remove pollen filter from both heater intake housings.
15. Remove 8 screws securing each heater intake housing to scuttle and remove intake housings. Release sealing rubbers from scuttle panel aperture.
16. Remove centre console. **See this section.**

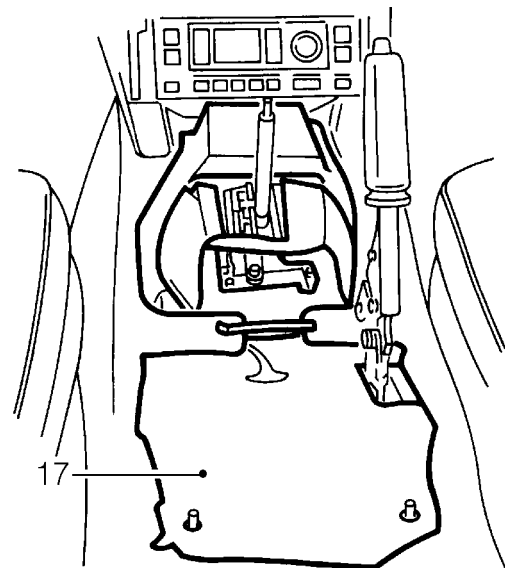

76M7219

17. Remove transmission tunnel insulation pad.

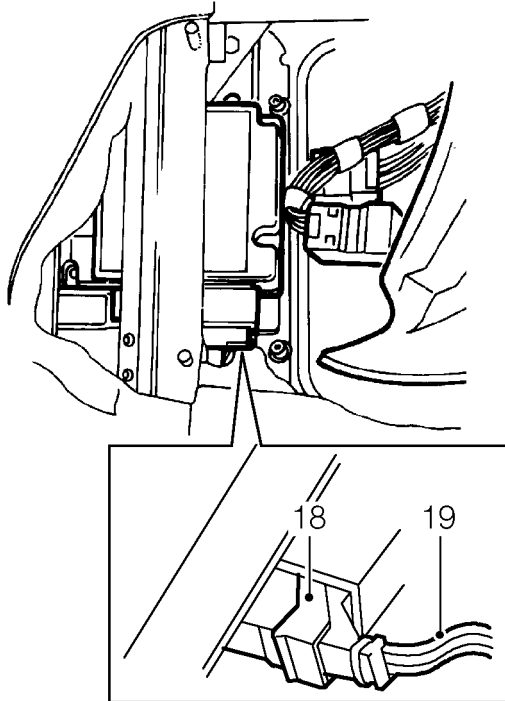

76M7220

18. Release latching mechanism and disconnect multiplug from airbag diagnostic and control unit (DCU).
19. Release SRS harness from transmission tunnel and position to fascia to avoid snagging.

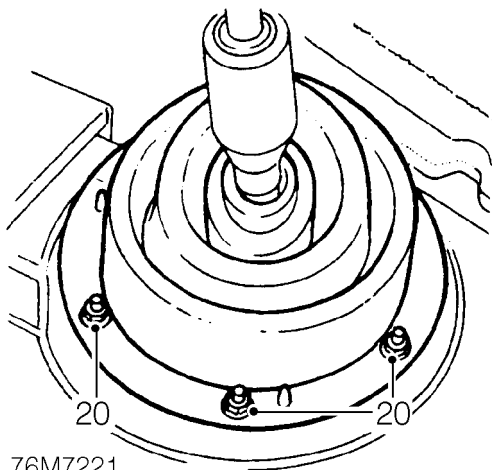

76M7221

20. Remove 6 nuts securing gear lever gaiter ring to transmission tunnel and release gaiter.

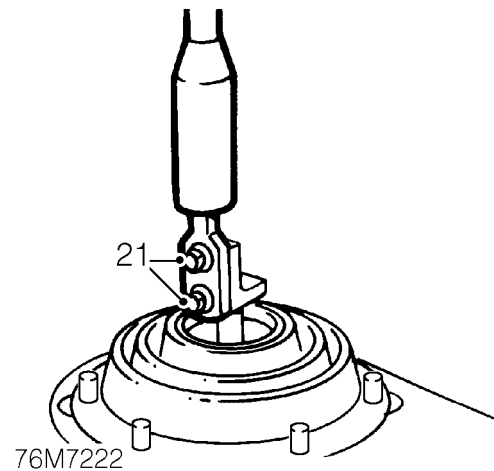

76M7222

21. Remove 2 bolts securing gear lever to gearbox remote and remove gear lever.

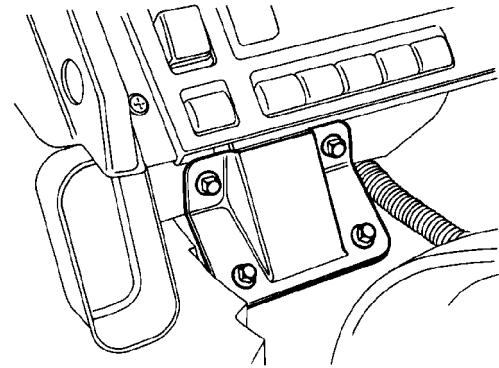

76M7223

22. Disconnect high/low switch multiplug.
23. Remove 4 bolts securing fascia centre bracket to fascia and transmission tunnel.
24. Remove fascia centre bracket.
25. Remove radio. **See ELECTRICAL, Repair.**
26. Remove steering column. **See STEERING, Repair.**

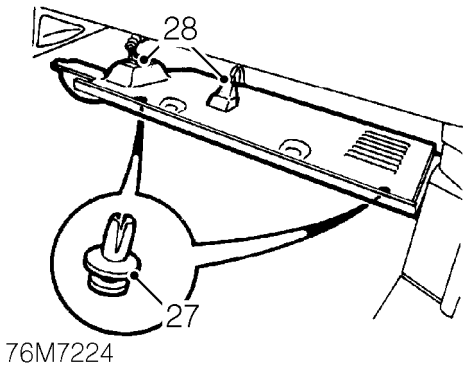

- 27. Remove 3 screws securing lower fascia closing panel to passenger's side of fascia.
- 28. Release closing panel and release diagnostic connector from panel.

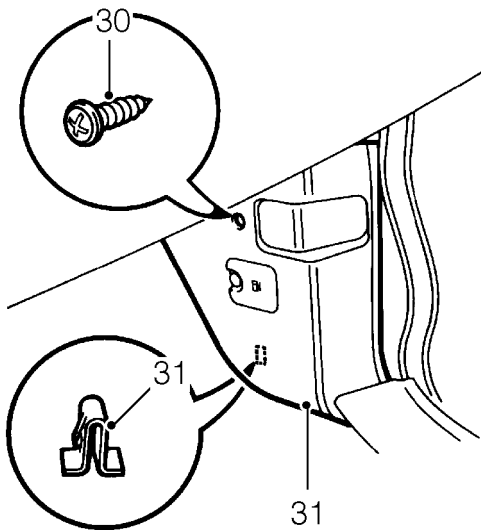

- 29. Release door aperture seal adjacent to 'A' post lower trim panels.
- 30. Remove screw securing each 'A' post lower trim panel to 'A' post.
- 31. Release 'A' post lower trim panels from sprag clip and remove panels.

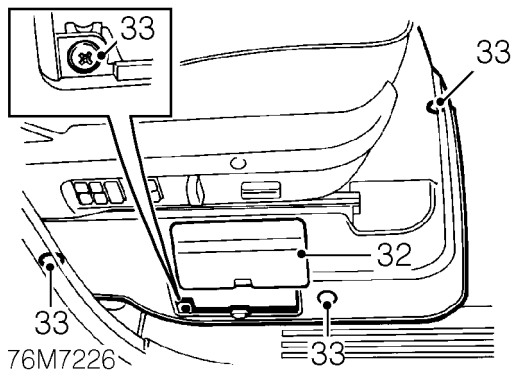

- 32. Remove fuse box cover from driver's seat base trim.

- 33. Remove screw and 3 trim studs securing seat base trim to body and remove seat base trim.

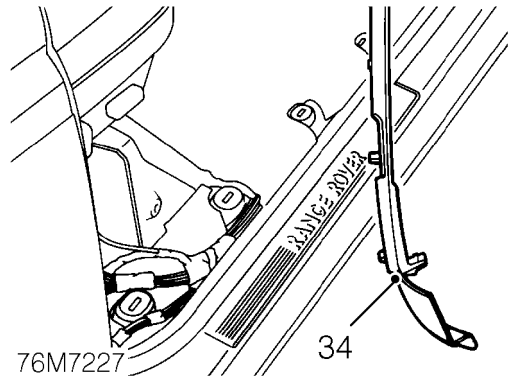

- 34. Release 4 sprag clips securing driver's side carpet retainer to body and remove carpet retainer.

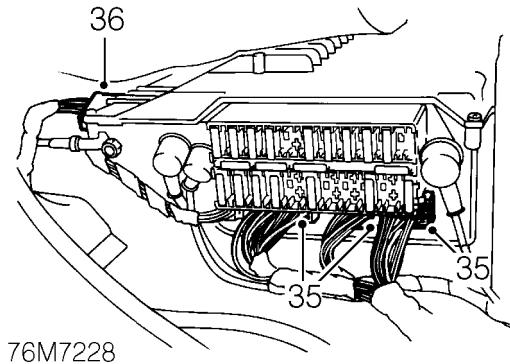

- 35. Disconnect 3 multiplugs from Body Electrical Control Module (BeCM).
- 36. Position carpet aside and disconnect multiplug from rear of BeCM.



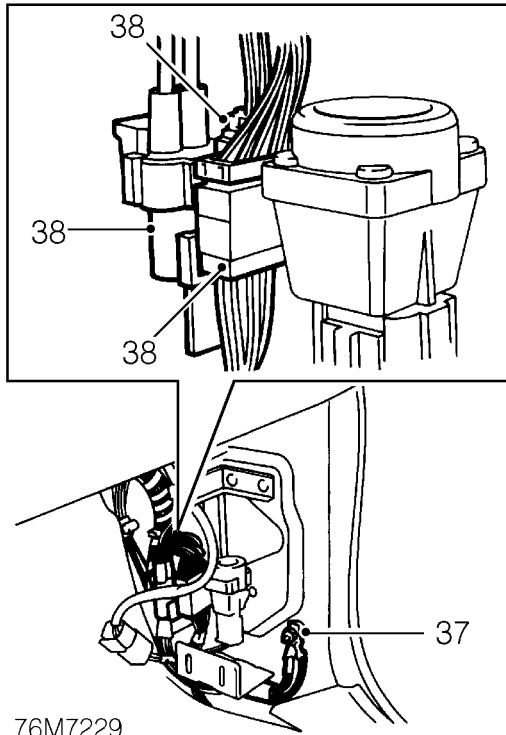

76M7229

37. Remove captive nut securing earth wires to driver's side lower 'A' post and release 3 additional earth wires.
38. Disconnect 3 multiplugs at base of driver's side 'A' post.
39. Release harness from driver's side carpet and position to fascia to avoid snagging.

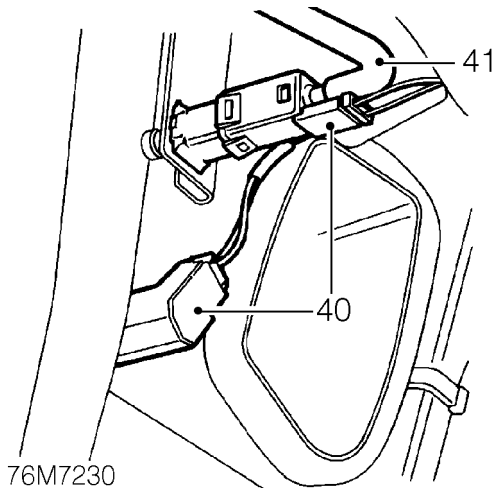

76M7230

40. Disconnect multiplugs from clutch and 2 brake pedal switches.
41. Disconnect vacuum hose from clutch and brake pedal switches.

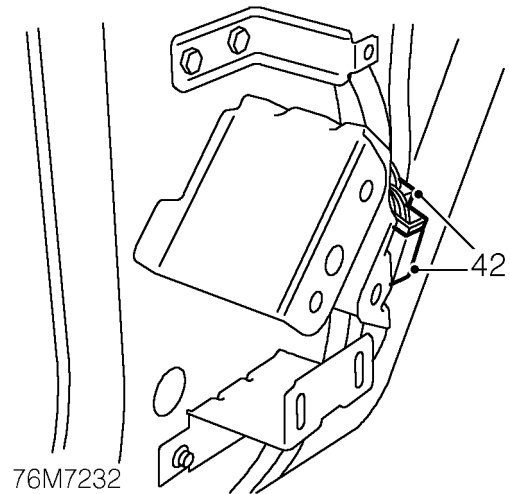

76M7232

42. Disconnect 2 multiplugs at base of passenger's side 'A' post.

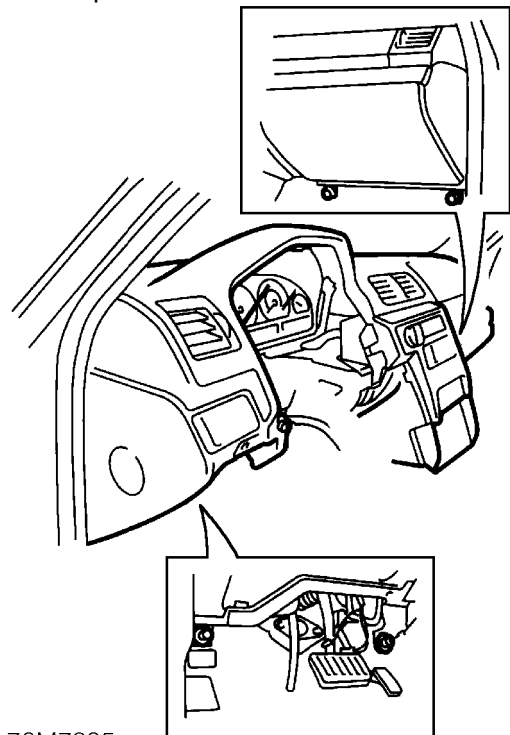

76M7235

43. Remove 2 nuts securing fascia to 'A' post and transmission tunnel bracket, passenger's side
44. Remove 2 nuts securing fascia to 'A' post and transmission tunnel bracket, driver's side.

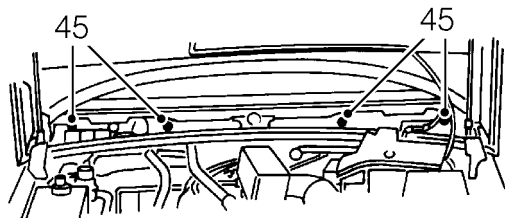

76M7233

45. Remove 4 tube bolts securing fascia assembly to scuttle panel.

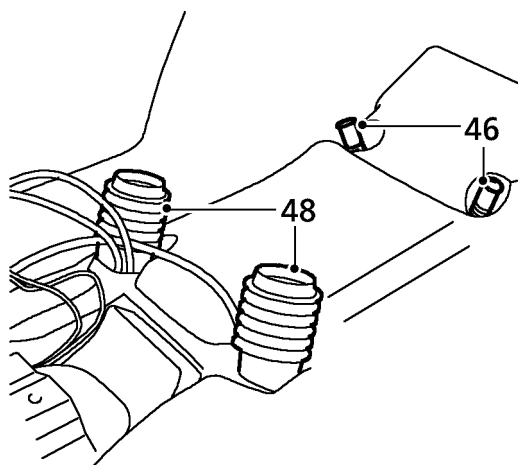

76M7236

46. Disconnect 2 evaporator drain hoses from evaporator.
47. Using assistance, carefully manoeuvre fascia assembly through the driver's door aperture. Position the fascia on a work surface with a soft covering and support on suitable wooden blocks.
48. Collect 2 ducts connecting rear heating pipes to fascia assembly.

#### Refit

49. Tape intake duct seals inside blower duct to aid fitment.
50. Fit guide pins LRT-76-001 to outer fascia studs.
51. With assistance, manoeuvre fascia assembly through driver's door aperture and locate guide pins to scuttle panel.



**NOTE: Assistance from a third person may be required to guide heater pipes through bulkhead.**

52. Fit one tube bolt securing fascia to scuttle panel but do not tighten.

53. Fit nuts securing fascia to lower 'A' posts and tighten to **25 Nm. (18 lbf.ft)**
54. Fit nuts securing fascia to transmission tunnel brackets and tighten to **25 Nm. (18 lbf.ft)**
55. Remove LRT-76-001.
56. Fit remaining tube bolts securing fascia to scuttle panel and tighten to **25 Nm. (18 lbf.ft)**
57. Fit fascia centre bracket, fit bolts and tighten to **25 Nm. (18 lbf.ft)**
58. Connect evaporator drain hoses to evaporator.
59. Fit ducts connecting rear heating pipes to fascia assembly.
60. Fit gearlever to gearbox remote, fit bolts and tighten to **25 Nm. (18 lbf.ft)**
61. Fit gear lever gaiter and ring to transmission tunnel and secure with nuts.
62. Connect high/low switch multiplug.
63. Position SRS harness to transmission tunnel.
64. Connect multiplug to airbag DCU. Ensure connector latching mechanism is correctly engaged.
65. Fit transmission tunnel insulation pad to transmission tunnel and position multiplugs through pad.
66. Fit radio. **See ELECTRICAL, Repair.**
67. Connect multiplugs at base of passenger's side 'A' post.
68. Fit passenger's side 'A' post lower trim panel and secure with screw.
69. Engage door aperture seal to door aperture.
70. Position fascia lower closing panel and engage diagnostic connector to panel.
71. Position closing panel to fascia and secure with scrivenets.
72. Connect vacuum hose to clutch and brake pedal switches.
73. Connect multiplugs to clutch and brake pedal switches.
74. Position harness to driver's side carpet.
75. Connect multiplugs to BeCM.
76. Connect multiplugs at base to driver's side 'A' post.
77. Position earth wires to 'A' post stud, fit and secure captive nut.
78. Fit driver's side carpet retainer and engage to clips.
79. Fit seat base trim and secure with trim studs and screw.
80. Fit seat base fuse box cover.
81. Fit driver's side lower 'A' post trim and secure with screw.
82. Fit steering column. **See STEERING, Repair.**
83. Fit radio. **See ELECTRICAL, Repair.**
84. Fit centre console. **See this section.**
85. Remove tape from heater intake ducts.
86. Engage heater intake seals to scuttle apertures.
87. Fit heater intake housings and secure with screws.
88. Fit pollen filters to intake housings.

89. Fit wiper motor and linkage. *See WIPERS AND WASHERS, Repair.*
90. Fit scuttle side panel to scuttle and secure with bolts.
91. Connect heated screen multiplug and engage multiplug to scuttle side panel bracket.
92. Remove caps from heater matrix pipes.
93. Engage heater matrix grommet to bulkhead aperture.
94. Connect heater hoses to heater matrix and secure with clips.
95. Remove caps from air conditioning pipes and TXV.
96. Lubricate NEW 'O' ring seals with clean compressor oil and fit to air conditioning pipes.
97. Connect air conditioning pipes to TXV, position clamp and fit bolt.
98. Tighten clamp bolt to **6 Nm. (4 lbf.ft)**
99. Charge air conditioning system. *See AIR CONDITIONING, Adjustment.*
100. Fill coolant system. *See COOLING SYSTEM, Repair.*
101. Connect both battery terminals, earth lead last.

---

### FASCIA CLOSING PANEL

---

Service repair no - 76.46.27

#### Remove

1. Remove closing panel screw covers and screws.
2. Lower closing panel.
3. Disconnect air tube from closing panel, remove panel.

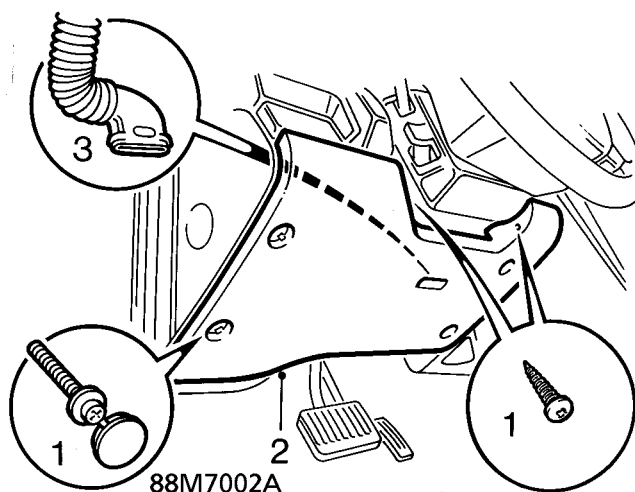

#### Refit

4. Reverse removal procedure.



## FRONT DOOR ASSEMBLY

Service repair no - 76.28.01/99

### Remove

1. Release door harness protective sleeve from 'A' post.
2. Disconnect door harness multiplugs.

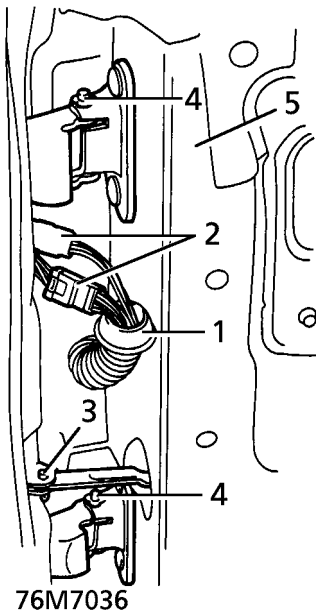

3. Remove door check strap retaining pin.



**CAUTION:** Apply protective tape to 'A' post before drifting out retaining pin.

4. Remove door hinge pin retaining clips.
5. With assistance, remove door assembly.

### Refit

6. With assistance, position door on hinges. Fit retaining clips.
7. Align door check strap. Fit retaining pin.
8. Remove protective tape from 'A' post.
9. Connect harness multiplugs. Secure protective sleeve to 'A' post.
10. If necessary adjust door. **See Adjustment.**

## GLASS - FRONT DOOR

Service repair no - 76.31.01

### Remove

1. Remove front door outer waist seal. **See this section.**
2. Remove front door plastic sheet. **See this section.**
3. Turn ignition ON.
4. Lower glass approximately 120mm (5 in.)  
Remove rear regulator arm retaining clip.

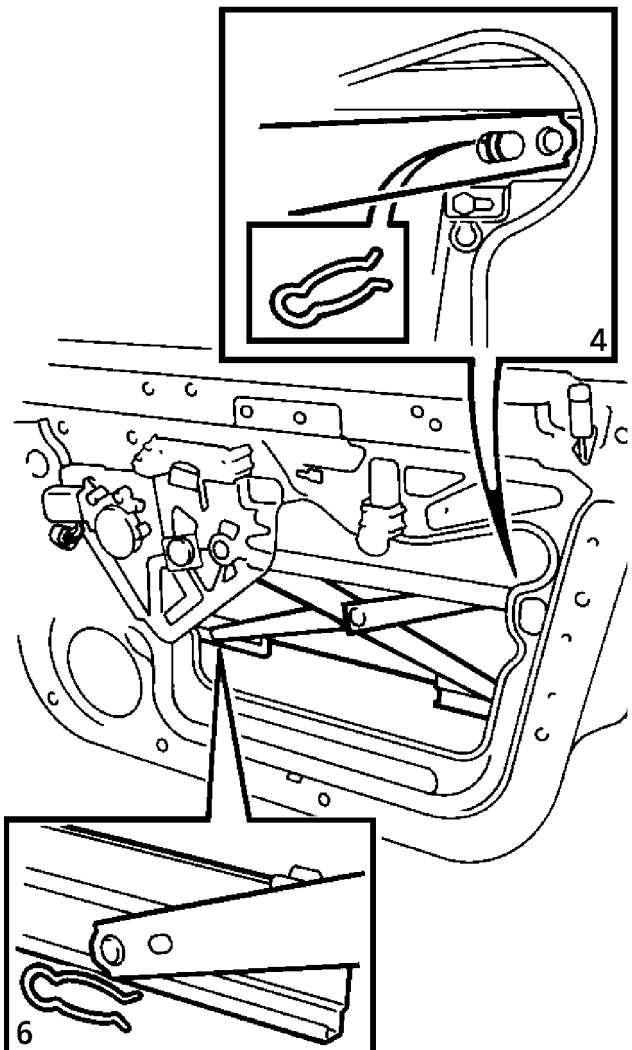

5. Lower glass to align forward clip with the regulator plate lower retaining rivet. Turn ignition OFF.

6. Remove front lower fixing clip.
7. Remove nut securing bracket to vertical slide.
8. Release bracket from slide.



**CAUTION:** Chock glass with wooden block, or retain with tape, to prevent glass dropping when regulator arms are released.

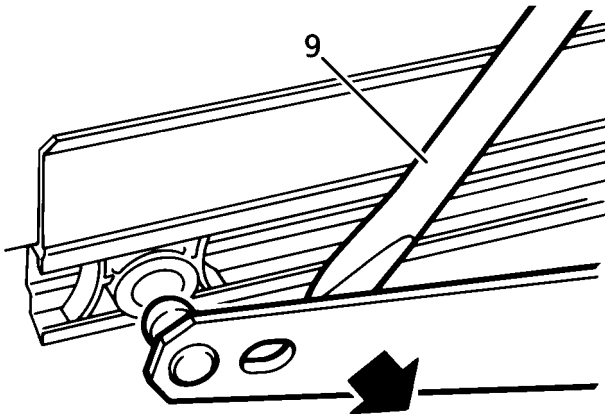

76M7059

9. Using a suitable lever, release 2 regulator arms from glass lower fixings.
10. Support weight of glass. Remove wooden chock or tape.

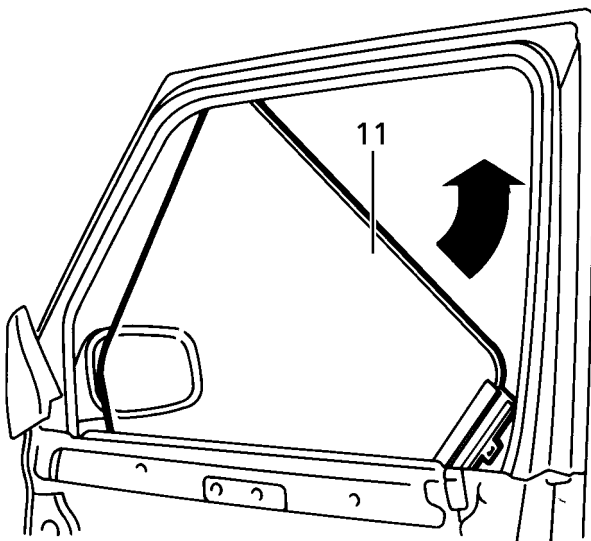

76M7060

11. Rotate glass anti-clockwise to release from runners.
12. Remove front door glass.

### Refit

13. Refit front door glass.
14. Rotate glass anti-clockwise, fit to runners.
15. Secure glass fixings to regulator arms.
16. Position glass bracket to vertical runner, fit retaining nut.
17. Fit clip securing regulator arm to glass runner.
18. Turn ignition ON.
19. Raise door glass approximately 120mm (5 in.)  
Fit rear glass retaining clip.
20. Raise door glass.
21. Turn ignition OFF.
22. Fit front door plastic sheet. *See this section.*
23. Fit front door outer waist seal. *See this section.*



## GLASS REGULATOR - FRONT DOOR

Service repair no - 76.31.45

### Remove

1. Remove front door glass. **See this section.**
2. Disconnect window lift motor harness connector.
3. Remove rivet securing regulator runner to door panel.

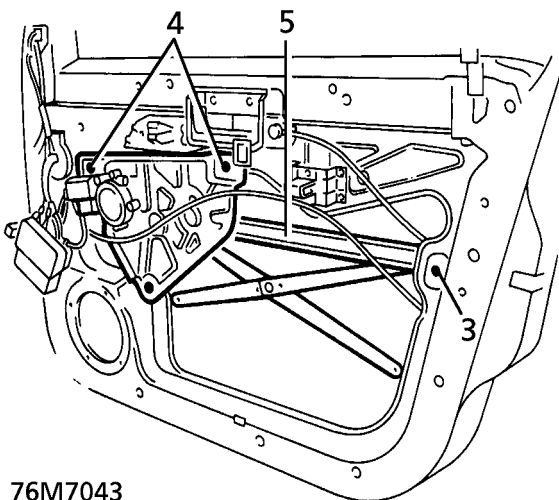

76M7043

4. Remove 3 rivets.
5. Remove regulator assembly.

### Refit

6. Reverse removal procedure.

## LATCH - FRONT DOOR

Service repair no - 76.37.12

### Remove

1. Remove front door trim casing. **See this section.**
2. Release rear of plastic sheet.
3. Release retaining clip, private lock to latch operating rod, at latch end.

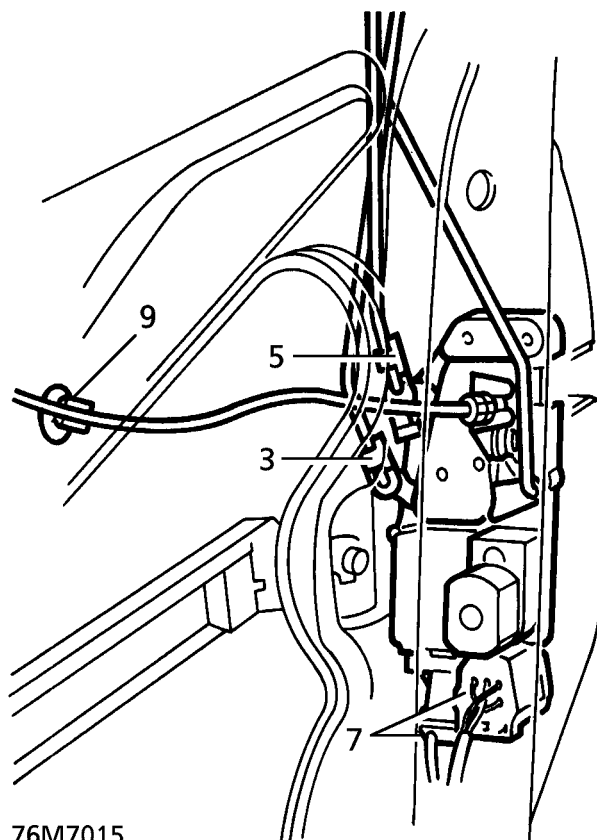

76M7015

4. Release control rod from latch.
5. Release retaining clip, outside handle to latch operating rod, at latch end.
6. Release control rod from latch.
7. Disconnect 2 latch motor multiplugs.
8. Remove door sill button from operating rod.
9. Release remote handle to latch operating cable from clip.
10. Remove 3 screws securing latch.
11. Release latch from door.
12. Remove sill button operating rod from latch.

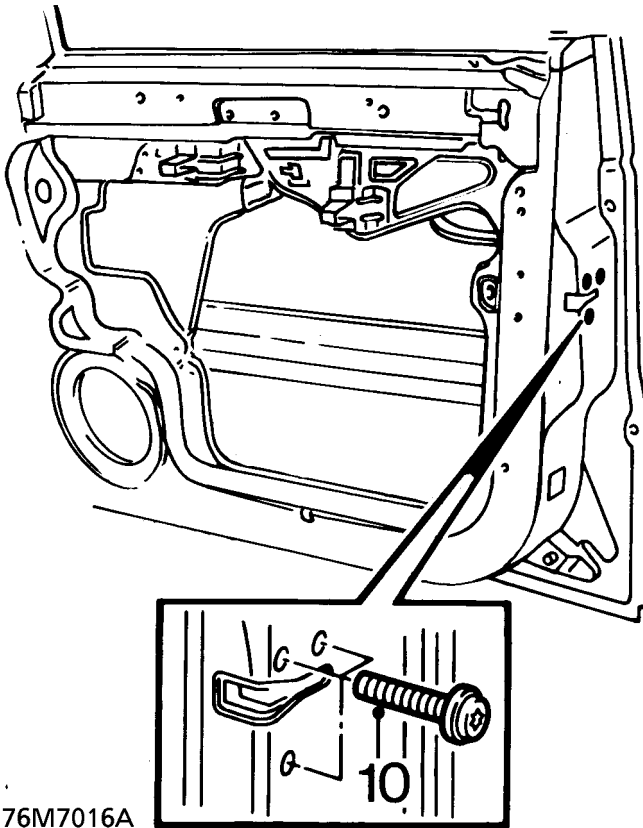

13. Release outer operating cable from latch abutment.
14. Release inner cable from latch.
15. Remove latch from door.

#### Refit

16. Fit latch.
17. Fit inner operating cable to latch.
18. Fit outer operating cable to latch abutment.
19. Fit sill button operating rod to latch.
20. Align latch to door, tighten 3 screws.
21. Secure remote handle cable to door panel clip.
22. Fit sill button to operating rod.
23. Reconnect 2 latch motor multiplugs.
24. Fit outside handle operating rod to latch.
25. Fit retaining clip.
26. Fit private lock operating rod to latch.
27. Fit retaining clip.
28. Secure plastic sheet.
29. Fit front door trim casing. **See this section.**

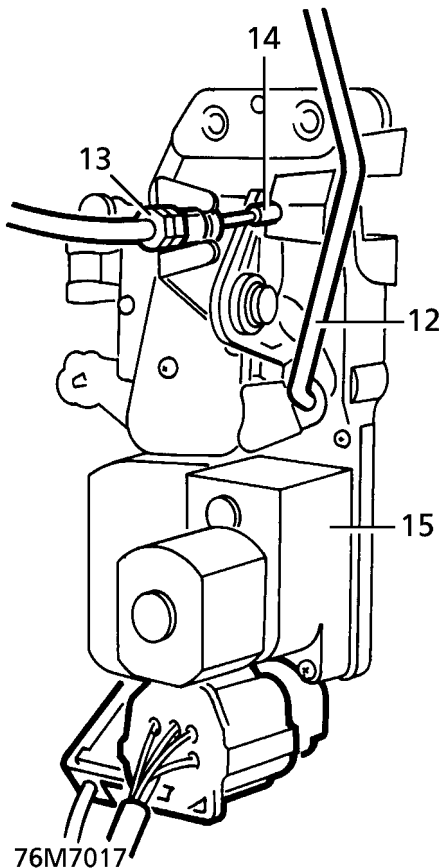



## REMOTE CONTROL - FRONT DOOR

Service repair no - 76.37.31

### Remove

1. Remove front door trim casing. **See this section.**
2. Release top rear corner of plastic sheet.
3. Pull remote handle out. Release inner cable from remote handle.

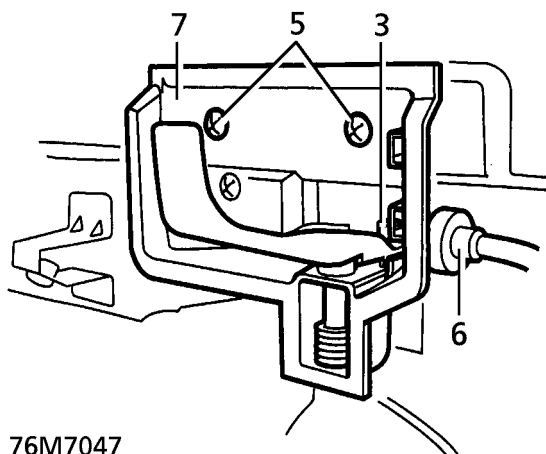

76M7047

4. Release remote handle.
5. Remove 2 screws securing remote handle.
6. Remove outer cable from housing.
7. Remove remote by sliding rearwards.

### Refit

8. Reverse removal procedure.

## OUTER WAIST SEAL - FRONT DOOR

Service repair no - 76.31.53

### Remove

1. Remove screw securing rear edge of outer waist seal.
2. Remove outer waist seal.

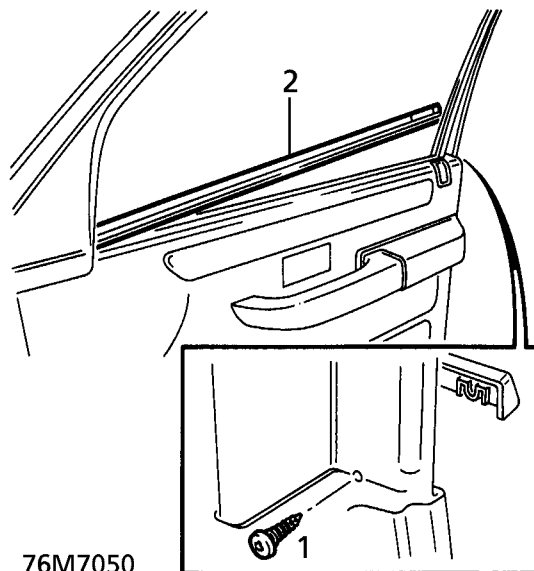

76M7050

### Refit

3. Reverse removal procedure.



---

**OUTSIDE HANDLE - FRONT DOOR**

---

Service repair no - 76.58.07

**Remove**

1. Remove front door trim casing. *See this section.*
2. Release rear half of plastic sheet.
3. Remove retaining clip, private lock to latch operating rod, at latch end.

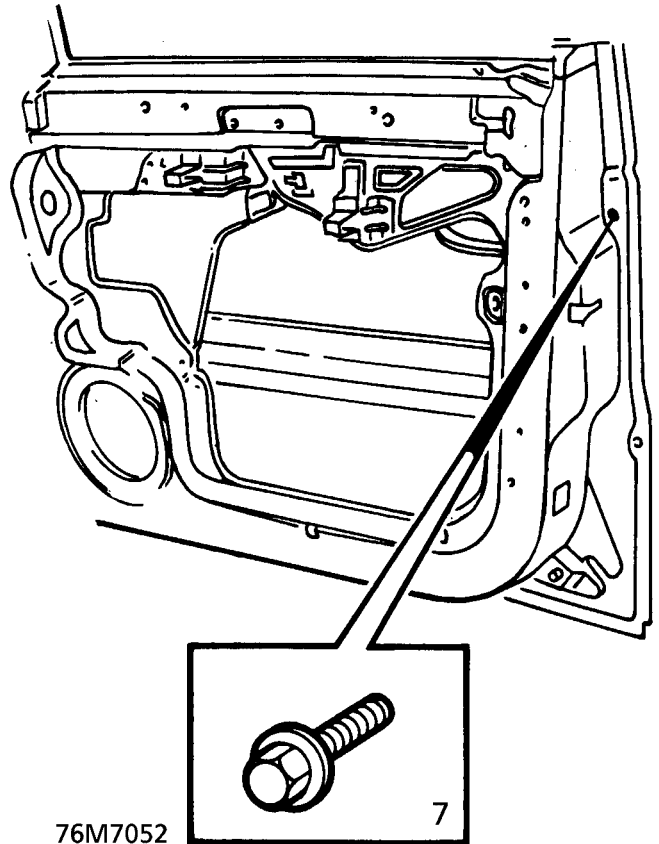
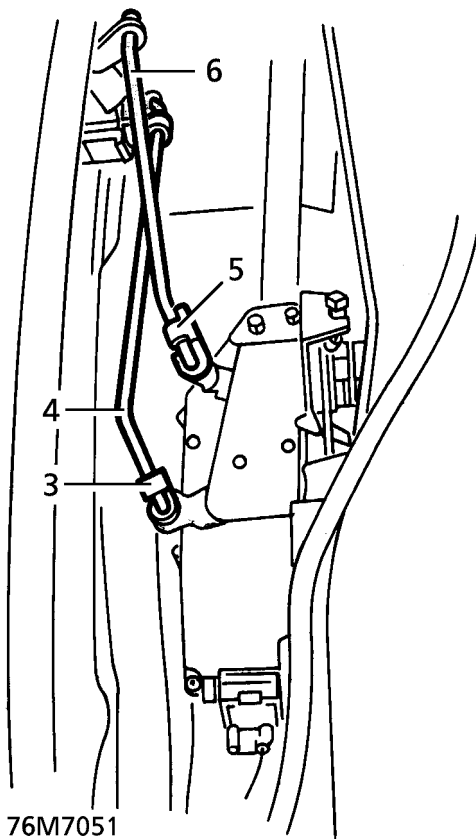

8. Slide outside handle forwards. Pull handle out, release rear of handle from door.

4. Remove control rod from latch and private lock.
5. Remove retaining clip, outside handle to latch operating rod, at latch end.
6. Remove control rod from latch and outside handle.
7. Remove bolt securing rear of outside handle.



---

**PLASTIC SHEET - FRONT DOOR**

---

Service repair no - 76.34.26

**Remove**

1. Remove front door trim casing. *See this section.*
2. Remove 2 screws securing door outstation ECU.

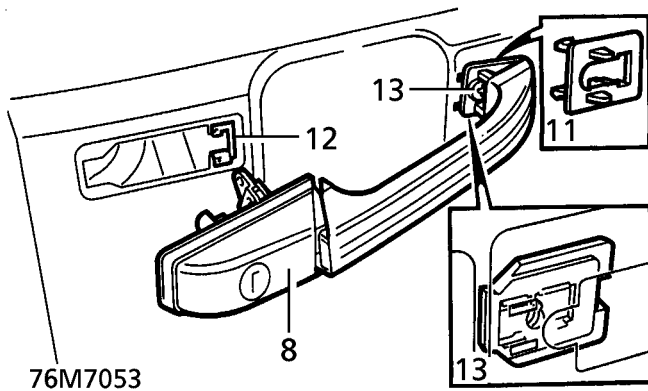

9. Remove handle from front fixing by pivoting rear end of handle out.
10. Remove gasket from handle.
11. Remove rubber locking plate from door.
12. Remove plastic locking plate from door.
13. Remove screw securing mounting plate to door, remove plate.

**Refit**

14. Clean handle and door mating faces.
15. Reverse removal procedure.

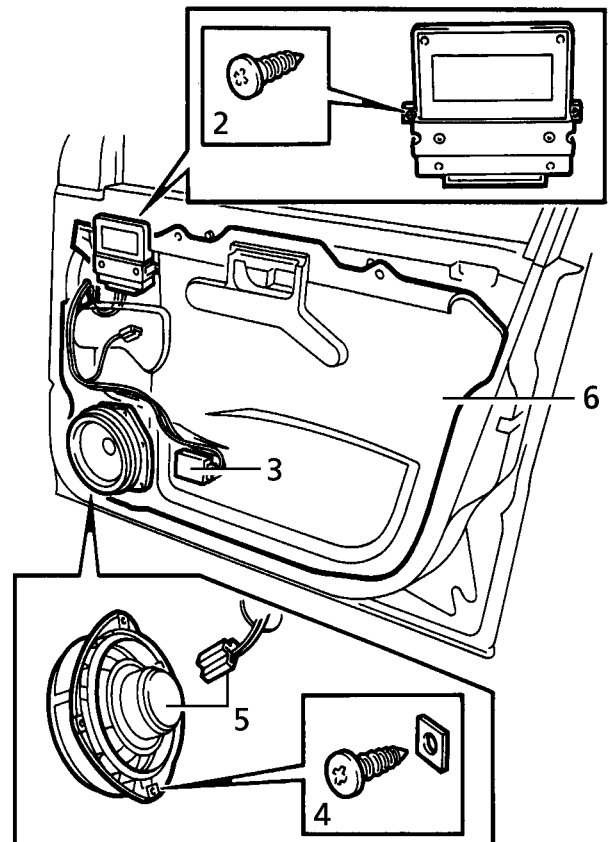

76M7042

3. Remove 2 screws securing speaker amplifier.
4. Remove 4 screws securing front door speaker.
5. Release speaker, disconnect multiplug.
6. Remove plastic sheet.

**Refit**

7. Reverse removal procedure.

**PRIVATE LOCK - FRONT DOOR**

Service repair no - 76.37.39

**Remove**

1. Remove outside handle. *See this section.*
2. Fit door lock key.
3. Remove screw securing lock.
4. Remove cam and washer from lock.
5. Remove cam lock and stop from lock.
6. Remove cam return spring. Remove lock from outside handle.

**Refit**

7. Apply grease to lock barrel.
8. Fit lock to outside handle.
9. Fit cam return spring, cam stop, cam lock, washer and cam.
10. Fit screw securing lock to outside handle.
11. Remove door lock key.
12. Refit front door outside handle. *See this section.*

**TRIM CASING - FRONT DOOR**

Service repair no - 76.34.01

**Remove**

1. Release cheater panel.

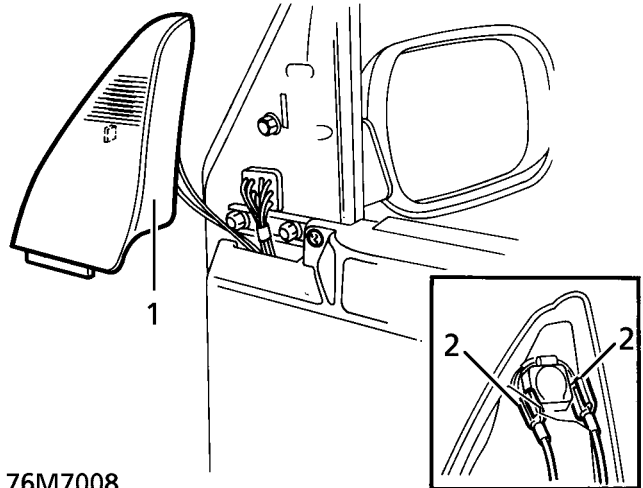

76M7008

2. Disconnect 2 tweeter speaker connectors, remove cheater panel.
3. Remove screw securing remote handle escutcheon, remove escutcheon.

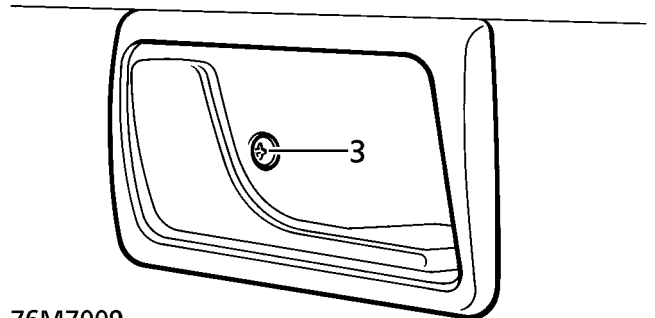

76M7009

4. Remove 3 screws securing trim casing.
5. Release 12 clips retaining trim casing.

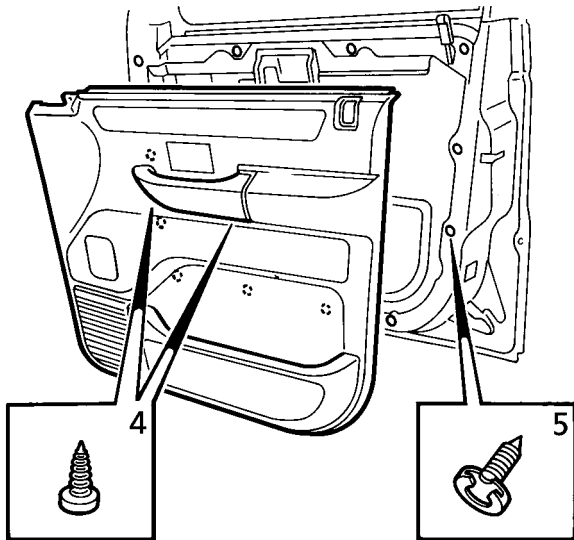

76M7010

6. Disconnect speaker connector.

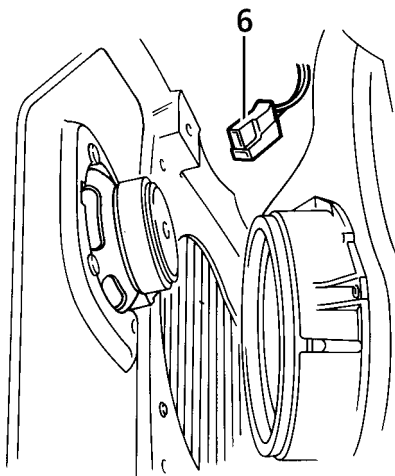

76M7011

7. Remove door trim casing.

**Disassemble**

- 8. Remove 12 trim casing retaining clips.
- 9. Remove 4 screws, remove speaker.

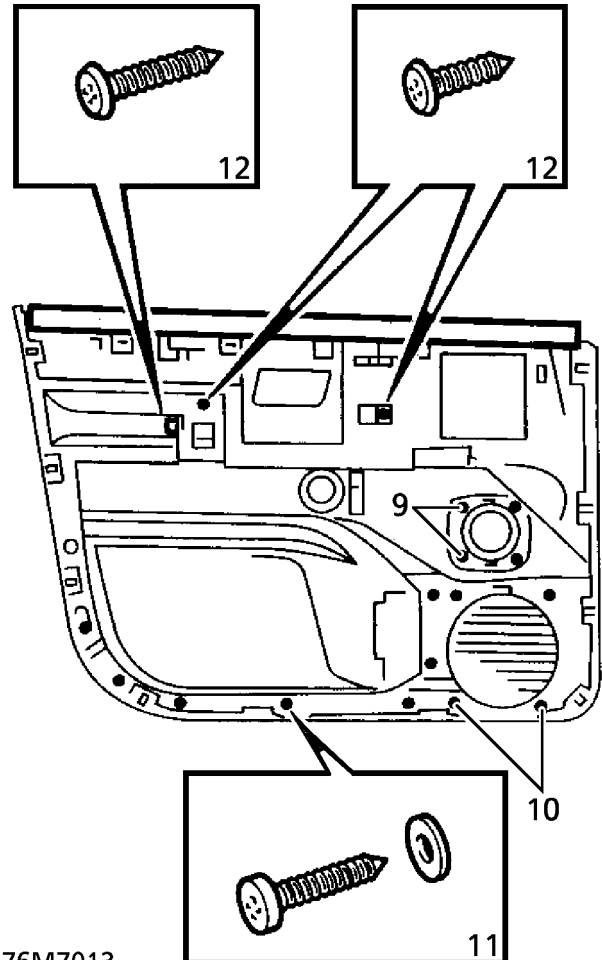

76M7013

- 10. Remove 4 screws, remove speaker grille.
- 11. Remove 7 screws, remove trim casing pocket.
- 12. Remove 3 screws, remove arm rest.
- 13. Remove retaining clamp and sill button escutcheon.

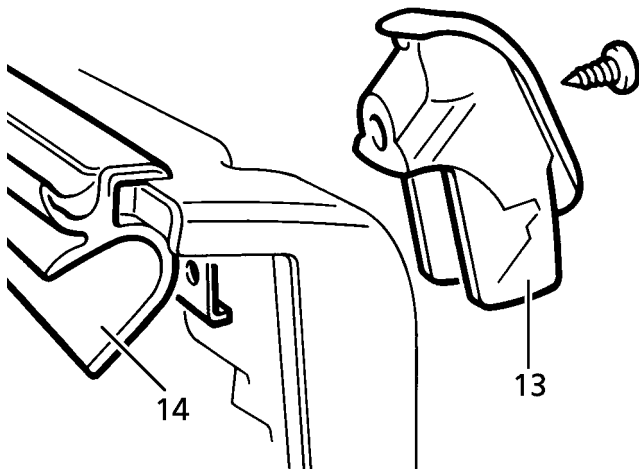

76M7014

14. Remove door trim casing waist seal.

#### Assemble

15. Fit door trim casing waist seal.
16. Fit sill button escutcheon, position retaining clamp, tighten screw.
17. Fit arm rest to trim casing, tighten 3 screws.
18. Fit trim casing pocket, tighten 7 screws.
19. Fit speaker grille to trim casing, tighten 4 screws.
20. Fit speaker to trim, tighten 4 screws.
21. Fit 12 retaining clips.

#### Refit

22. Connect trim casing speaker connector.
23. Fit trim casing, locating 12 retaining clips.
24. Fit 3 screws securing trim casing.
25. Fit remote handle escutcheon, tighten screw.
26. Position cheater panel, connect 2 tweeter speaker connectors.
27. Secure cheater panel.

#### INSERT CAPPING - FRONT DOOR

Service repair no - 76.34.32

#### Remove

1. Fit protection to door trim casing.
2. Position a blunt flat blade between trim casing and insert upper edge.
3. Gently raise blade to remove insert.
4. Remove retaining clips from insert.

#### Refit

5. Fit insert to door casing. Secure with clips.
6. Remove protection from door casing.



## REAR DOOR ASSEMBLY

Service repair no - 76.28.02/99

### Remove

1. Release door harness protective sleeve from 'B/C' post.
2. Disconnect door harness multiplugs.
3. Remove check strap retaining pin.

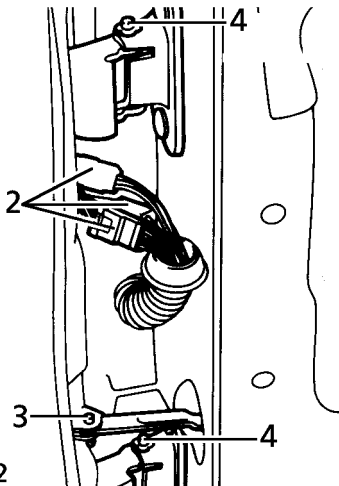

76M7132



**CAUTION:** Apply protective tape to 'B/C' post before drifting out pin.

4. Remove hinge pin retaining clips.
5. With assistance, remove door assembly.

### Refit

6. With assistance fit door to hinges.
7. Fit hinge retaining clips.
8. Align check strap and fit retaining pin.
9. Remove protective tape.
10. Connect harness multiplugs, secure protective sleeve to 'B/C' post.
11. If necessary adjust door. **See Adjustment.**

## GLASS - REAR DOOR

Service repair no - 76.31.02

### Remove

1. Remove outer waist seal. **See this section.**
2. Remove door trim casing. **See this section.**
3. Remove speaker and plastic sheet. **See this section.**
4. Remove window motor and control panel assembly. **See ELECTRICAL, Repair.**
5. Remove glass rear channel. **See this section.**
6. Remove wedges or tape from glass.
7. Release glass from channel. Raise to remove glass from door.

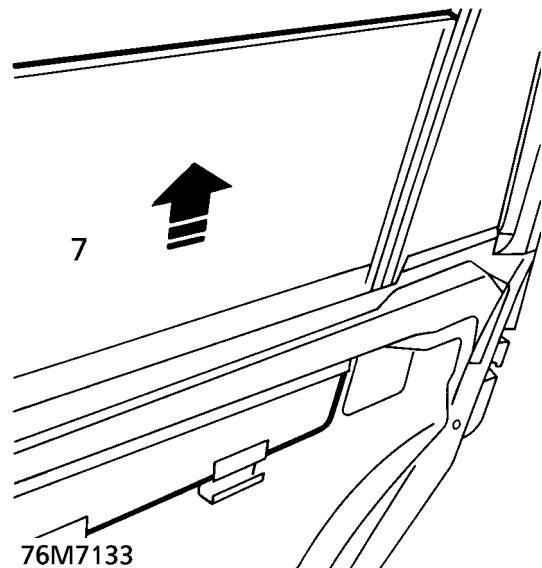

76M7133

### Refit

8. Fit glass to door and align to frame.
9. Wedge or use tape to hold glass in door.
10. Fit glass rear channel. **See this section.**
11. Fit window motor and control panel. **See ELECTRICAL, Repair.**
12. Fit speaker and plastic sheet. **See this section.**
13. Fit trim casing. **See this section.**
14. Fit outer waist seal. **See this section.**

**PLASTIC SHEET - REAR DOOR**

Service repair no - 76.34.28

**Remove**

1. Remove rear door trim casing. *See this section.*
2. Remove speaker. *See ELECTRICAL, Repair.*
3. Remove 2 screws securing amplifier to door.
4. Remove plastic sheet.

**Refit**

5. Reverse removal procedure.

**OUTSIDE HANDLE - REAR DOOR**

Service repair no - 76.58.02

**Remove**

1. Remove rear door trim casing. *See this section.*
2. Remove bolt securing handle.

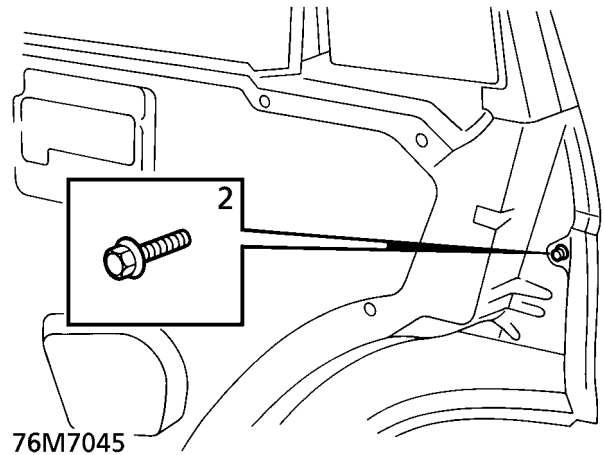

3. Remove outside handle.

**NOTE:** Operate and pull handle outward, pivoting at forward mounting point.

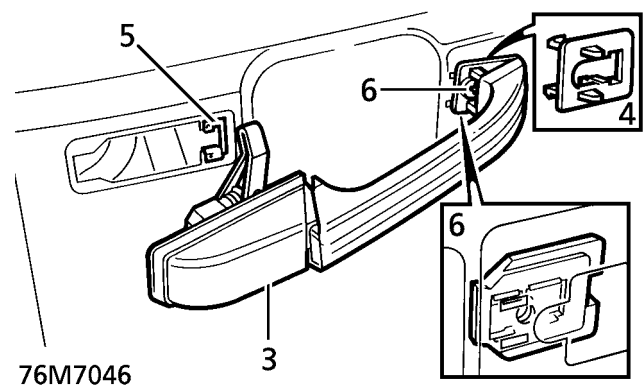

4. Remove gasket.
5. Remove locking plates.
6. Remove screw securing mounting plate, remove plate.



## Refit

7. Clean handle face on door.
8. Fit handle mounting plate, tighten screw.
9. Fit locking plates.
10. Fit gasket to handle, position handle, secure with screw.
11. Refit door trim casing. **See this section.**

## LATCH - REAR DOOR

Service repair no - 76.37.13/70

### Remove

1. Remove window lift motor/control unit assembly. **See ELECTRICAL, Repair.**
2. Release door lock remote control cable from clip on window lift panel.
3. Remove 2 studs securing latch to window lift panel.

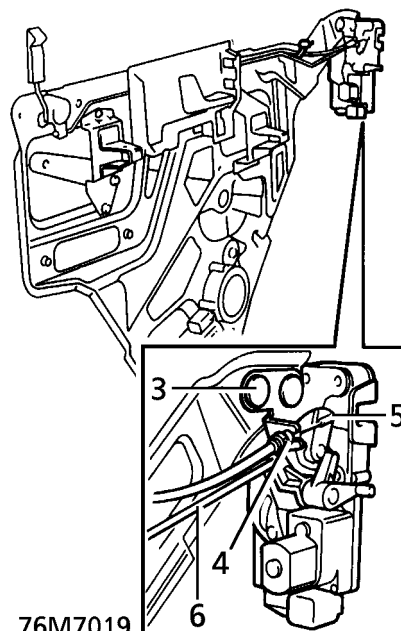

4. Disconnect outer cable from abutment bracket.
5. Release remote cable from latch.
6. Release sill button link rod from latch. Remove latch.

### Refit

7. Lubricate new latch.
8. Fit latch to sill button link rod.
9. Fit remote control cable to latch.
10. Fit latch to window lift panel, secure with 2 retaining studs.
11. Refit window lift motor/control unit assembly. **See ELECTRICAL, Repair.**



**FIXED QUARTER LIGHT - REAR DOOR**

Service repair no - 76.31.31

**Remove**

1. Remove outer waist seal. **See this section.**
2. Remove door trim casing. **See this section.**
3. From inside release seal from frame. Remove seal and glass assembly outwards.
4. Remove seal from glass.

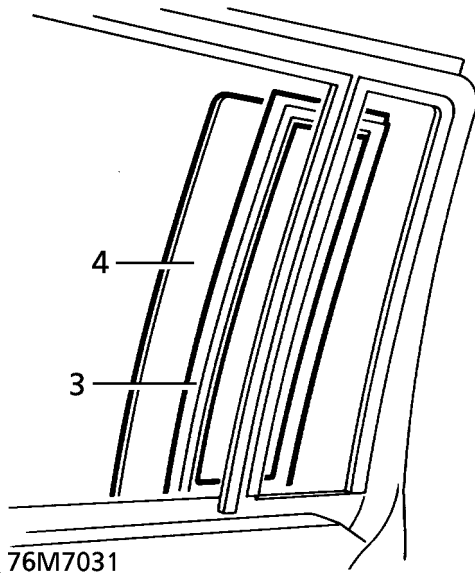
**Refit**

5. Clean glass, seal and frame.
6. Fit seal to glass. Fit assembly to door frame. If necessary use a draw string to locate rubber.



**NOTE:** The opening light seal fits over the fixed glass seal.

7. Fit door trim casing. **See this section.**
8. Fit outer waist seal. **See this section.**

**REMOTE CONTROL - REAR DOOR**

Service repair no - 76.37.32

**Remove**

1. Remove rear door trim casing. **See this section.**
2. Release plastic sheet to clear remote.
3. Remove foam pad from under window lift switch multiplug.
4. Disconnect switch multiplug.

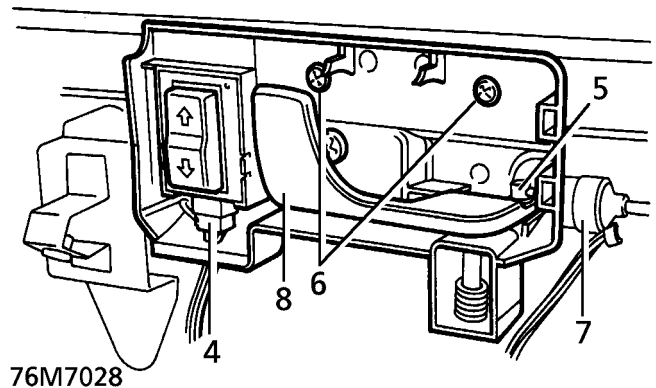

5. Release inner cable from remote lever.
6. Remove 2 screws securing remote to window lift control panel.
7. Release remote outer cable from remote housing.
8. Remove remote control.

**Refit**

9. Reverse removal procedure.



---

**GLASS CHANNEL - REAR DOOR**

---

Service repair no - 76.31.17

**Remove**

1. Remove window lift motor/control panel assembly. **See ELECTRICAL, Repair.**
2. Remove 2 bolts securing channel to door and remove channel.

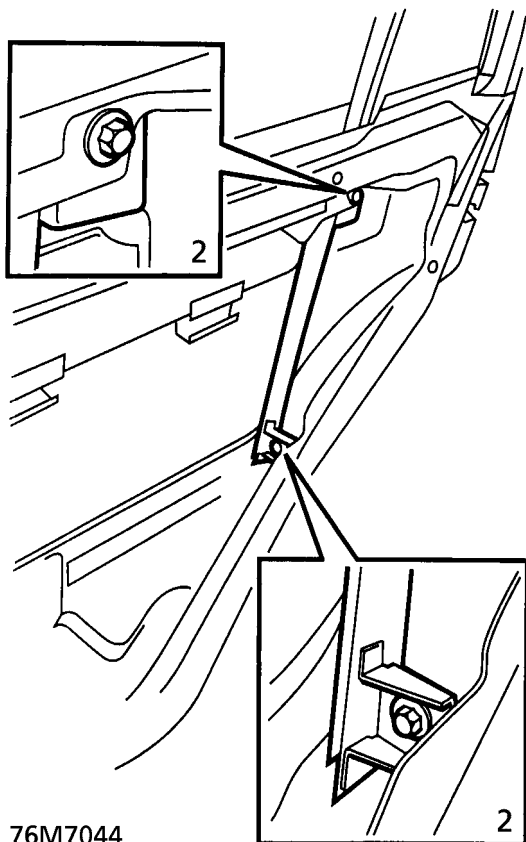

76M7044

**Refit**

3. Fit channel to door, secure with 2 bolts.
4. Refit window lift motor/control panel assembly. **See ELECTRICAL, Repair.**

---

**SEAL - REAR DOOR**

---

Service repair no - 76.40.02

**Remove**

1. Open rear door.
2. Remove rear door carpet retainer.
3. Remove rear door aperture seal.

**Refit**

4. Fit rear door aperture seal.
5. Refit rear door carpet retainer.
6. Close rear door.

---

**TRIM CASING - REAR DOOR**

---

Service repair no - 76.34.04

**Remove**

1. Remove remote handle escutcheon.

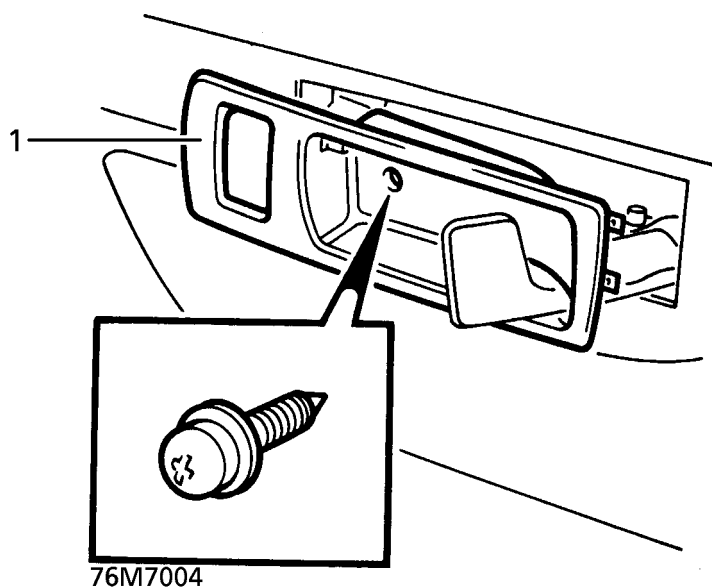

76M7004

2. Remove 2 screws securing trim casing.

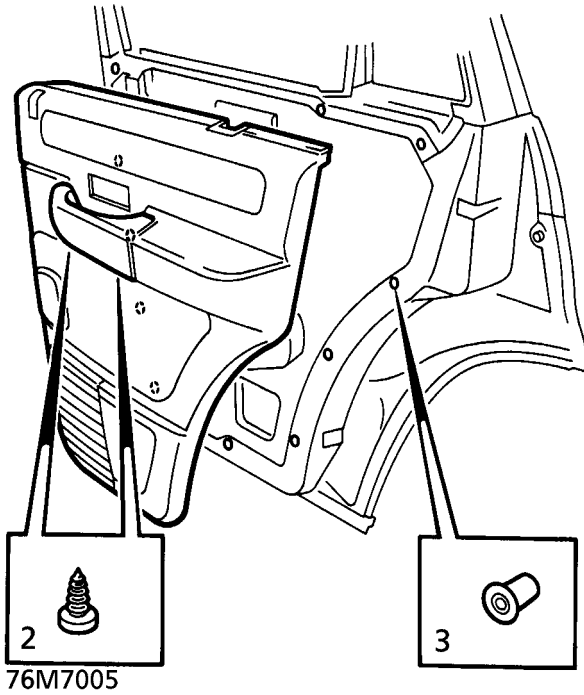

3. Release 11 door trim casing retaining studs.  
4. Disconnect rear door speaker connector.  
Remove door trim casing.

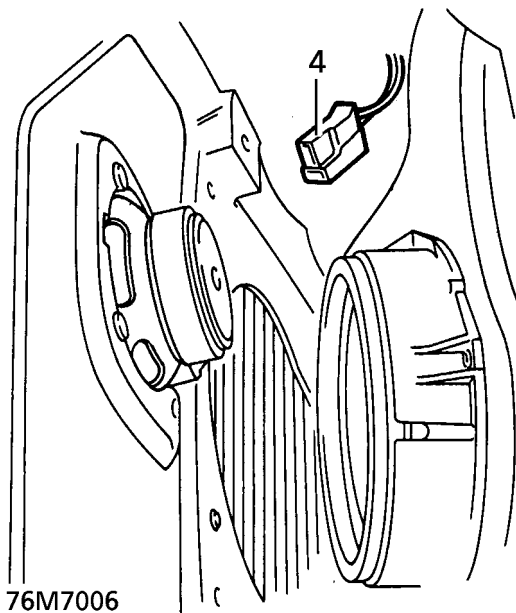

### Disassemble

5. Remove 11 trim casing retaining studs.

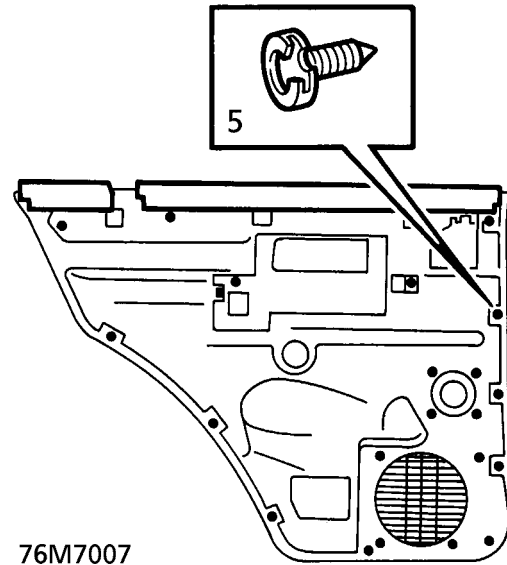

6. Remove 4 screws, remove upper speaker grille.  
7. Remove 4 screws, remove lower speaker grille.  
8. Remove 3 screws, remove arm rest.  
9. Remove screw, remove retaining clamp and sill button escutcheon.

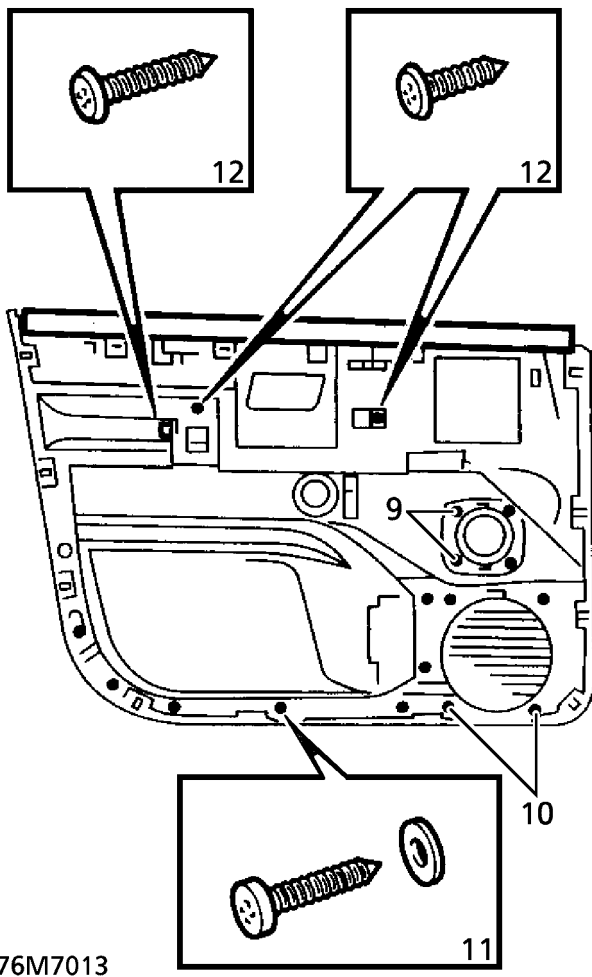

76M7013

10. Remove trim from door casing.

#### Assemble

11. Fit trim to door casing.
12. Fit sill button escutcheon and position retaining clamp.
13. Tighten screw securing retaining clamp.
14. Fit arm rest to trim casing, secure with 3 screws.
15. Fit upper speaker grille to trim casing, secure with 4 screws.
16. Fit lower speaker grille to trim casing, secure with 4 screws.
17. Fit 11 trim casing retaining studs.

#### Refit

18. Fit and align door trim casing.
19. Secure 11 trim casing retaining studs.
20. Tighten 2 screws securing trim casing.
21. Fit remote handle escutcheon, tighten securing screw.

#### OUTER WAIST SEAL - REAR DOOR

Service repair no - 76.31.54

#### Remove

1. Remove screw securing seal finisher to forward edge of door.
2. Release seal finisher from clip at rear edge of door.
3. Remove seal and finisher assembly.
4. Remove screw and securing clip.

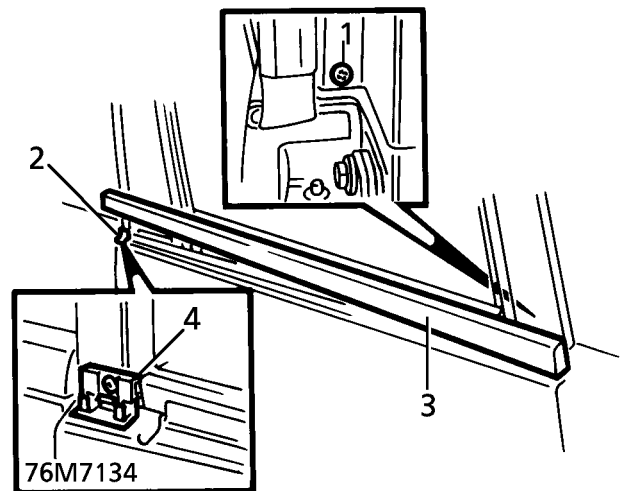

#### Refit

5. Fit clip to door, secure with screw.
6. Fit seal and finisher assembly to door. Align at forward edge, secure with screw.

## RUBBING STRIPS & DOOR FINISHERS

### Remove



**CAUTION:** When removing exterior trim, NEVER lever directly against body panels. Use an approved trim fork. Protect body panel with suitable material, such as fabric covered hardboard.

### Rubbing Strip - Front Fender

1. Remove relevant wheel arch liner. *See this section.*
2. Remove nut securing forward edge of rubbing strip.
3. Remove rubbing strip from single clip.

### Rubbing Strip - Rear Quarter Panel

4. Release 5 clips securing rubbing strip. Remove strip.



**NOTE:** Rearmost clip is unique.

### Rubbing Strips - Front & Rear Doors

5. Remove nut securing rear of rubbing strip.
6. **Front Door Rubbing Strip:** Release 5 clips securing rubbing strip.
7. **Rear Door Rubbing Strip:** Release 3 clips securing rubbing strip.
8. Remove rubbing strips.

### Lower Door Finishers

9. Remove screw securing rear of finisher.
10. **Front Door Finisher:** Release 5 clips securing rubbing strip.
11. **Rear Door Finisher:** Release 3 clips securing rubbing strip.
12. Remove finishers.

### Refit

13. Reverse removal procedure.

## GLOVE BOX AND LID

Service repair no - 76.52.03 - Glove Box

Service repair no - 76.52.02 - Glove Box Lid

Service repair no - 76.52.13 - Glove Box Lid - Align

### Remove

1. Remove centre screw from 2 scrivet fasteners. Release closing panel for access to glove box hinge fixings. Collect outer parts of fasteners from closing panel.

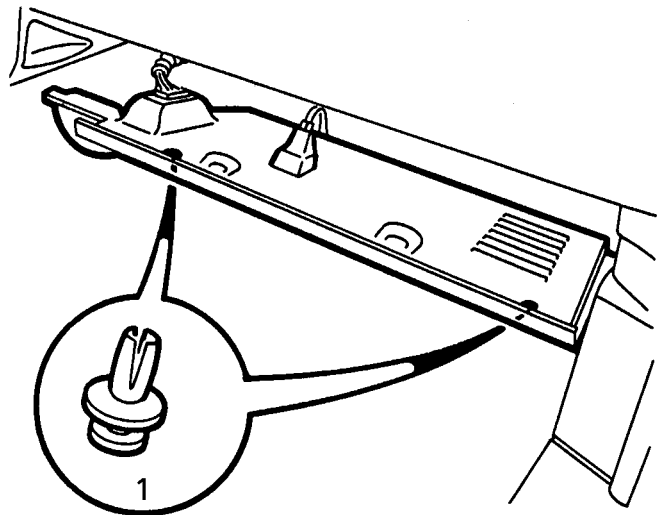

76M7054

2. Remove 2 bolts securing glove box hinges to fascia frame.
3. Open glove box lid, remove 5 screws securing glove box. Release glove box from fascia.

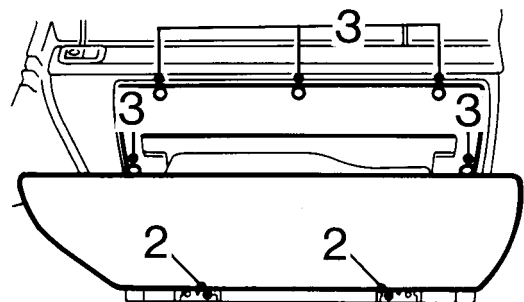

76M7189

4. Disconnect glove box lamp multiplug.



5. Disconnect cable latch, remove glove box assembly.

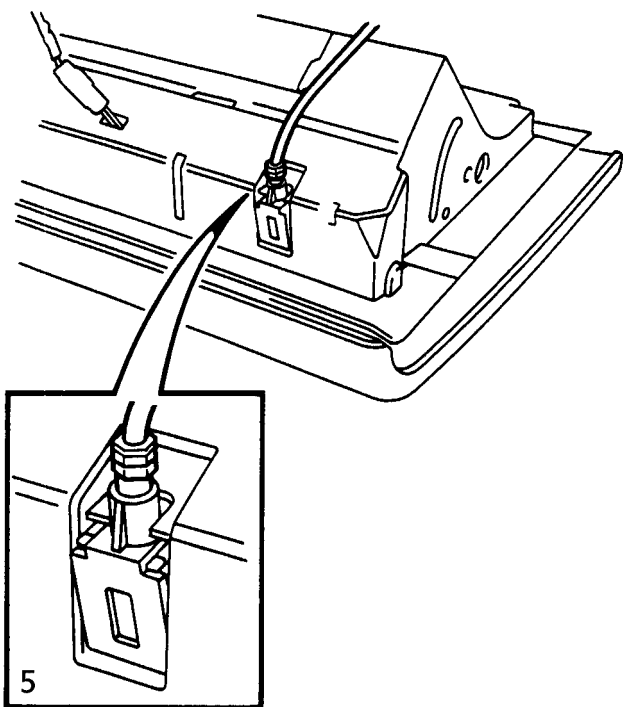

76M7056

### Glove Box Lid

6. Remove split pin, disengage gas strut from lid.

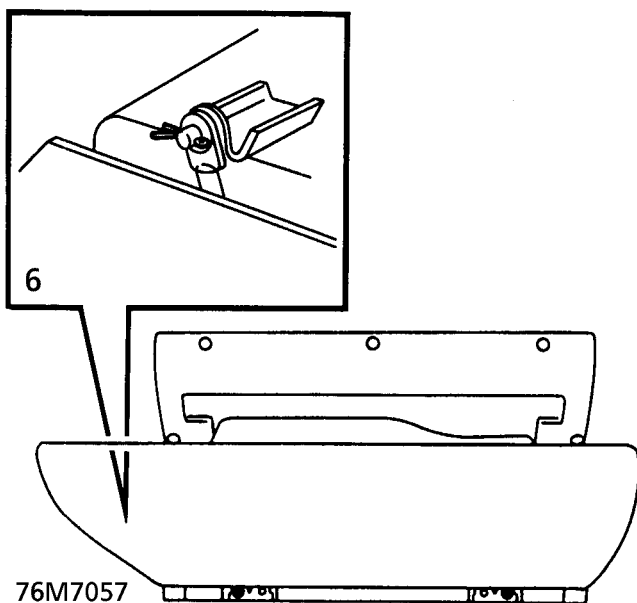

76M7057

7. Remove 2 bolts and square nuts, remove lid from glove box.

### Refit Glove Box Lid

8. Position lid to glove box and secure with bolts and square nuts.
9. Engage gas strut, secure with split pin.

### Refit Glove Box Assembly

10. Position glove box assembly, connect lamp multiplug. Secure cable latch.
11. Open glove box lid, align assembly to fascia. Secure with screws.
12. Fit bolts securing hinges to fascia frame, do not tighten.
13. Check alignment and latching of glove box lid, adjusting hinges as necessary using central adjusting screws.
14. Tighten screws, hinges to fascia.
15. Close glove box lid.
16. Position closing panel. Secure with scrivet fasteners.

## GLOVE BOX RELEASE CABLE

Service repair no - 76.52.14



**NOTE:** Release cables are supplied preset and do not normally require adjustment.

## Remove

1. Open glove box. Remove 5 screws securing glove box liner to fascia.

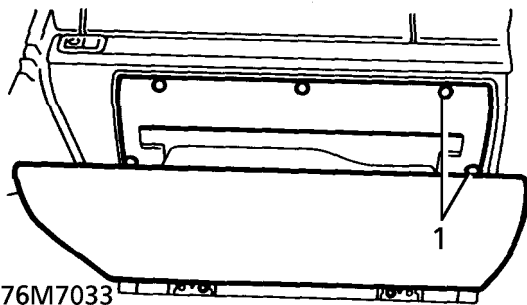

76M7033

2. Lower glove box liner. Release 2 clips to disengage cable latch from location.

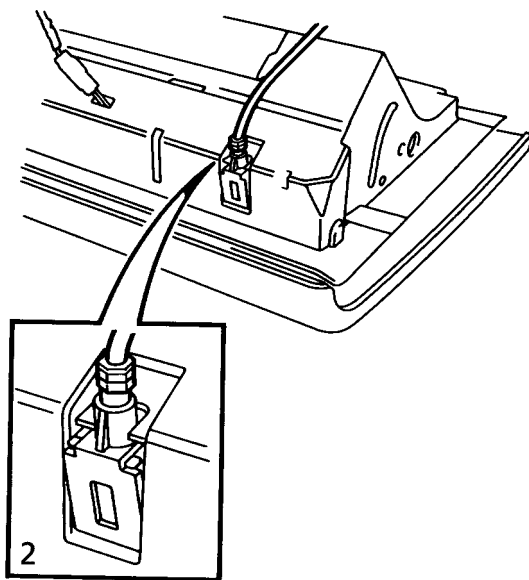

76M7034

3. Remove finisher from lock.

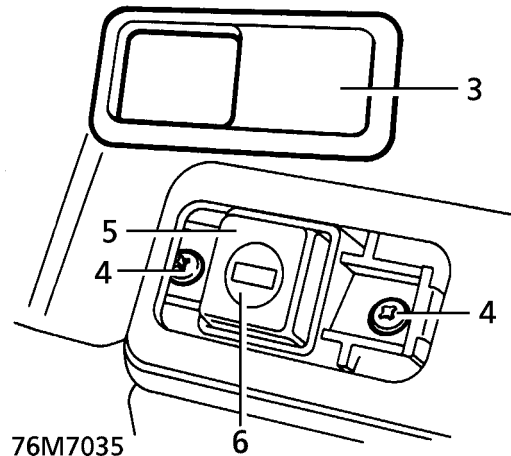

76M7035

4. Remove 2 screws securing lock and withdraw cable assembly from fascia.
5. Pry cover from lock button.
6. Insert key into lock, turn key through 45 degrees, remove barrel.

## Refit

7. Insert barrel, turn to engage in button.
8. Remove key, fit cover to lock button.
9. Route release cable assembly into fascia. Engage cable latch to glove box.
10. Align glove box liner to fascia, tighten screws.
11. Close glove box lid.
12. Position glove box lock to fascia, check operation of latch.
13. If adjustment is necessary, release lock from fascia, loosen cable lock nut, adjust outer cable length. Tighten cable lock nut.
14. Reposition lock to fascia. Recheck operation of latch before securing lock with screws.
15. Fit finisher to lock.



## GRAB HANDLE

Service repair no - 76.58.30

### Remove

1. Pull down grab handle.
2. Remove 2 grab handle retaining screw access covers.
3. Remove 2 screws, remove grab handle.

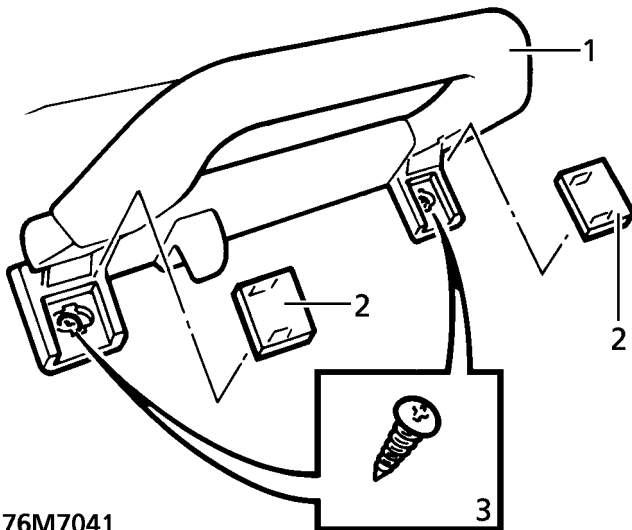

76M7041

### Refit

4. Position grab handle, fit 2 retaining screws.
5. Fit 2 retaining screw access covers.
6. Release grab handle.

## FRONT GRILLE

Service repair no - 76.55.03

### Remove

1. Remove 6 screws securing grille.
2. Remove front grille.

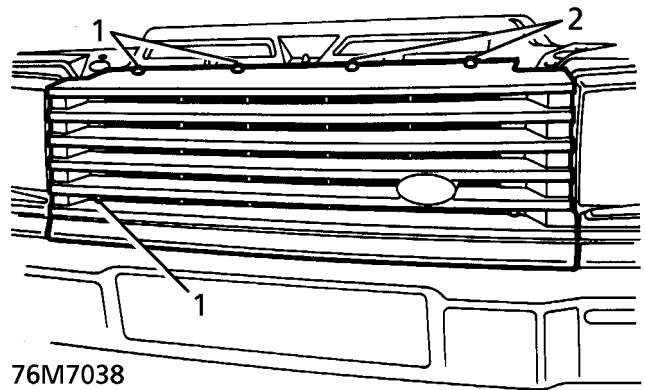

76M7038

### Refit

3. Reverse removal procedure.



**EXTERIOR MIRROR**

Service repair no - 76.10.52

**Remove**

1. Release cheater panel, disconnect 2 tweeter speaker connectors. Remove cheater panel.
2. Disconnect mirror multiplug.
3. Remove 3 screws, remove mirror.

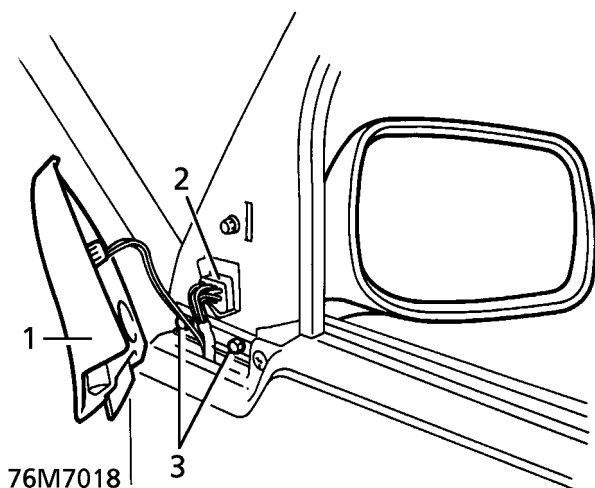
**Refit**

4. Fit mirror, tighten 3 retaining screws.
5. Connect mirror multiplug.
6. Position cheater panel, connect 2 tweeter speaker connectors, secure panel to door.

**INTERIOR MIRROR**

Service repair no - 76.10.51

**Remove**

1. Remove cover.
2. If fitted, disconnect multiplug.
3. Remove mirror from windscreen location by pulling sharply downwards.

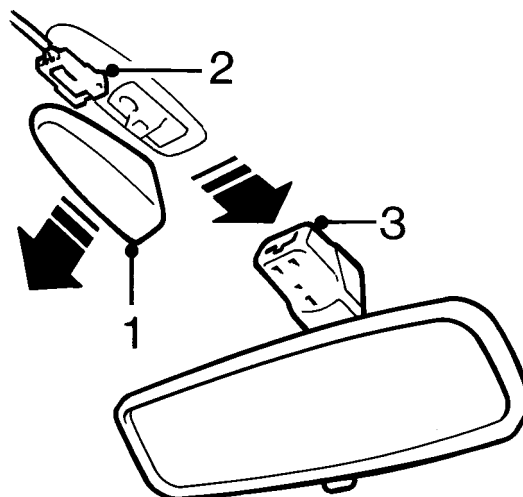
**Refit**

4. Reverse removal procedure.



## PARCEL TRAY SUPPORT

Service repair no - 76.67.11

### Remove

1. Release 2 squab catches and fold rear seats forward.

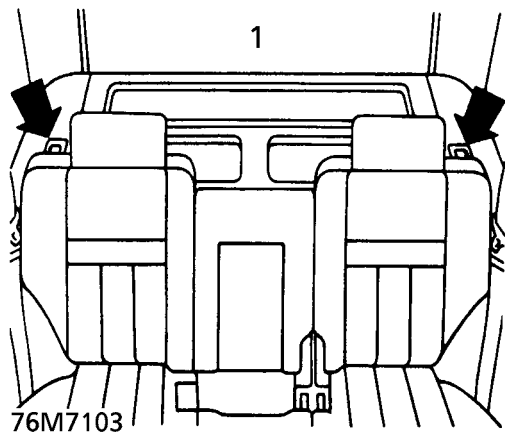

2. Remove parcel tray.
3. Remove 3 studs securing parcel tray support. Remove support.

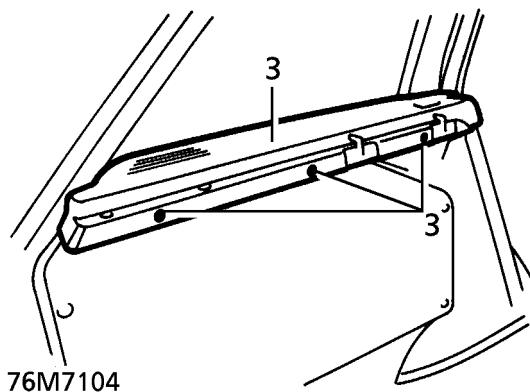

### Refit

4. Reverse removal procedure.

## PARCEL TRAY SUPPORT TRIM

Service repair no - 76.67.12 - Right Hand

Service repair no - 76.67.21 - Left Hand

### Remove

1. Remove parcel tray support. *See this section.*
2. Remove 'D' post lower trim.
3. Release tailgate aperture seal from support trim flange.
4. Remove 3 trim studs.

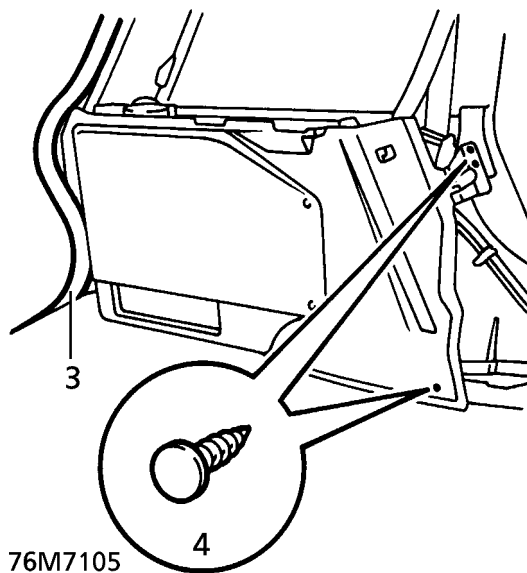

### LH Trim Only

5. Remove CD autochanger. *See ELECTRICAL, Repair.*
6. Remove 2 nuts and 2 bolts securing sub-woofer assembly.

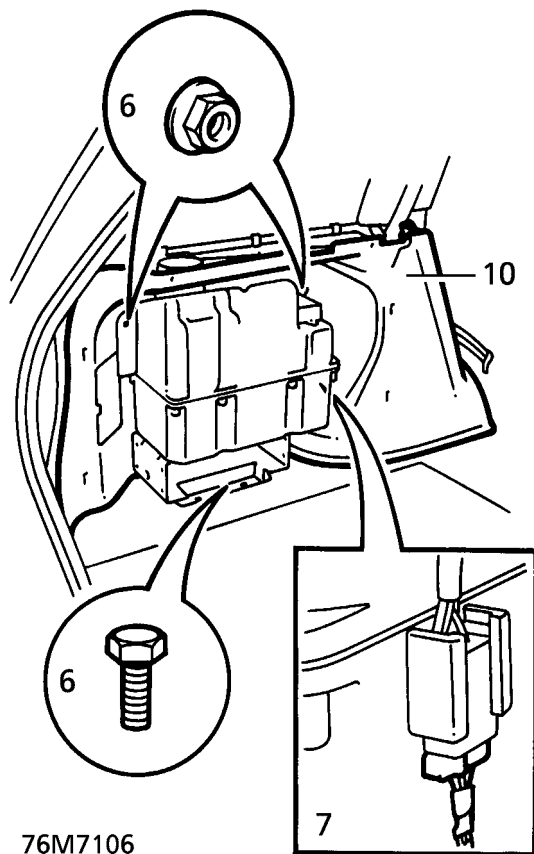

76M7106

7. Disconnect multiplug from sub-woofer.

#### Both Trim Panels

8. Release 2 sprag clips securing support trim to body.
9. Remove support trim panel.
10. **LH Trim Only:** Separate sub-woofer from trim panel.

#### Refit

11. Reverse removal procedure.

#### A,B,D and E POST TRIMS

##### Remove

1. Remove aperture seal from appropriate area.
2. Remove retaining screws ('A' post lower trims)
3. Remove seat belt top mounting ('B' and 'D' post upper trims)
4. Release retaining clips, remove finisher.

##### Refit

5. Position finisher, secure with retaining clips and screws.
6. Fit seat belt top mounting. Tighten to **25 Nm. (18 lbf. ft)**
7. Secure aperture seal.



**NOTE:** Illustration 76M 7128 shows the fixing method for the A, B, D and E post trim finishers.

1. A post upper
2. A post lower left hand
3. A post lower right hand
4. B post upper
5. B post lower
6. D post upper
7. D post lower
8. E post

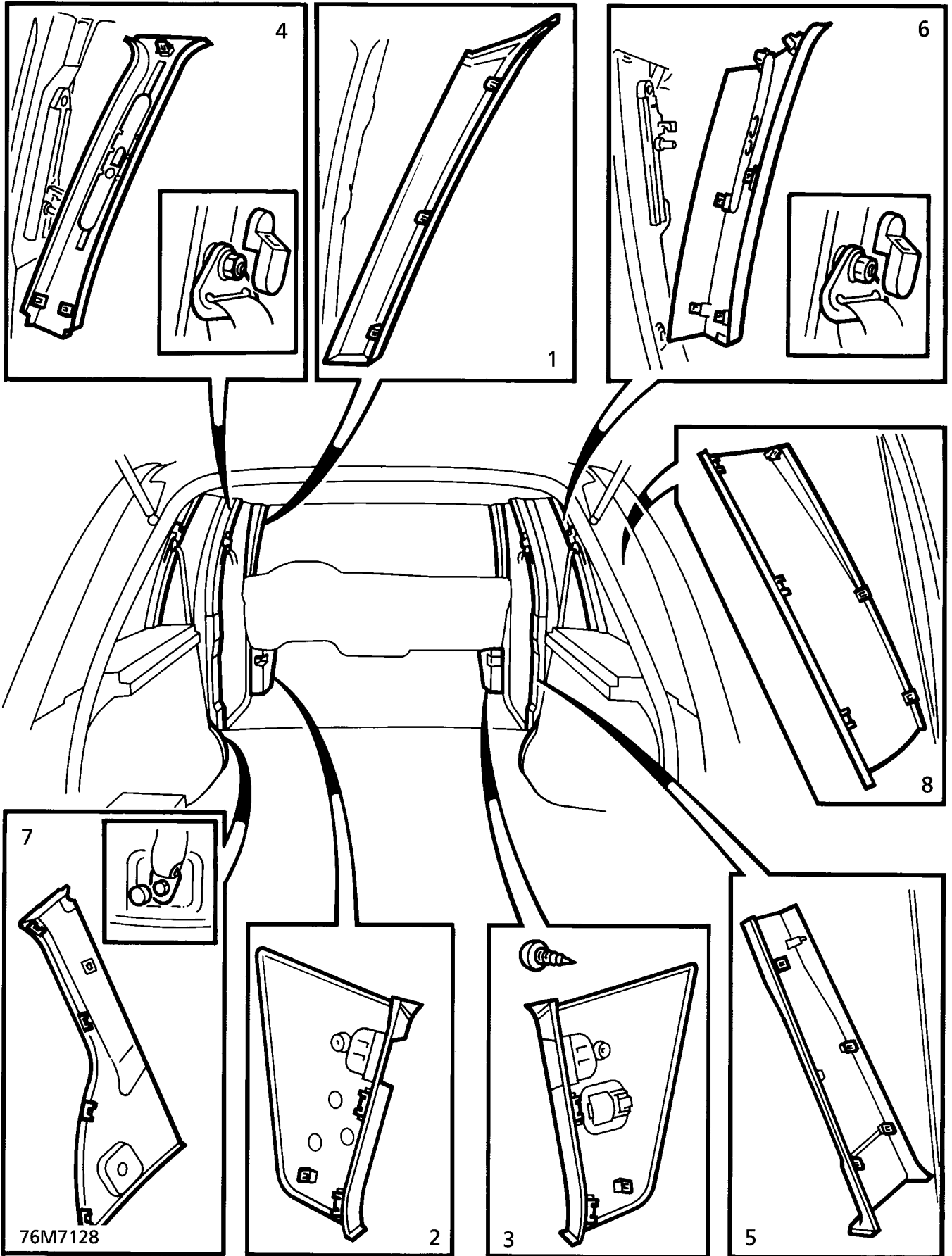

**'E' POST - EXTERIOR TRIM**

Service repair no - 76.43.

**Remove**

1. Open upper tailgate.
2. Remove 3 screws securing trim to 'E' post.

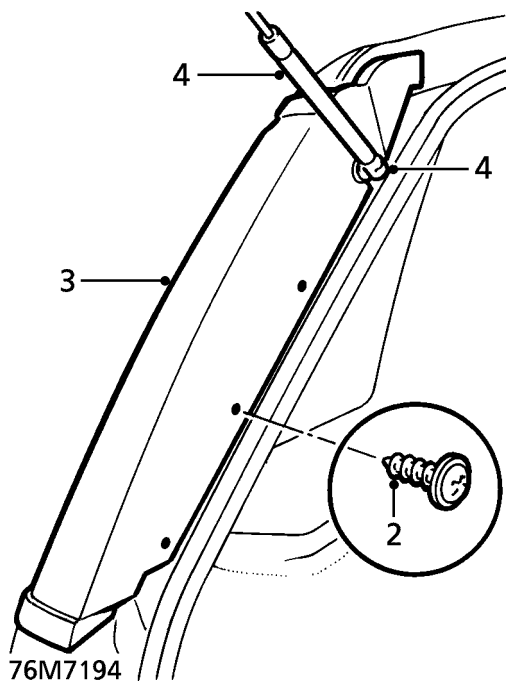

3. Remove trim.

**Refit**

4. Position trim to 'E' post, engage slot beneath special washer on tailgate strut ball joint and engage channel to rear edge of quarter glass.
5. Secure trim with screws.
6. Close tailgate.

**SEAT BELT - FRONT**

Service repair no - 76.73.13

**Remove**

1. Remove lower 'B' post finisher.

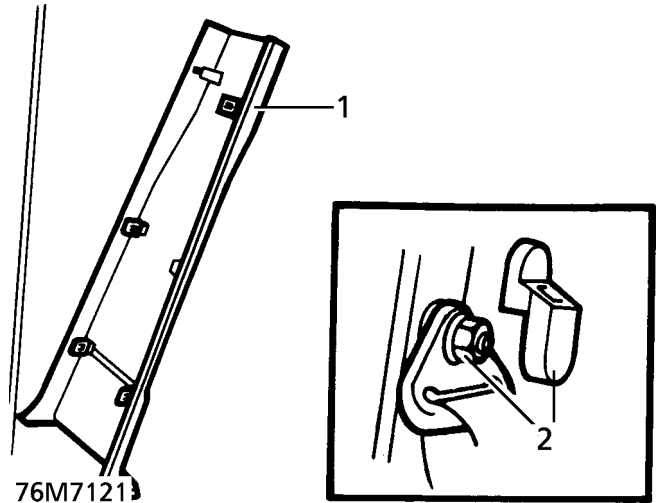

2. Remove cover and nut securing seat belt to upper anchorage point.
3. Release seat belt guide from 'B' post.
4. Move seat fully forwards.
5. Remove bolt cover. Release seat belt from lower anchorage point on seat.

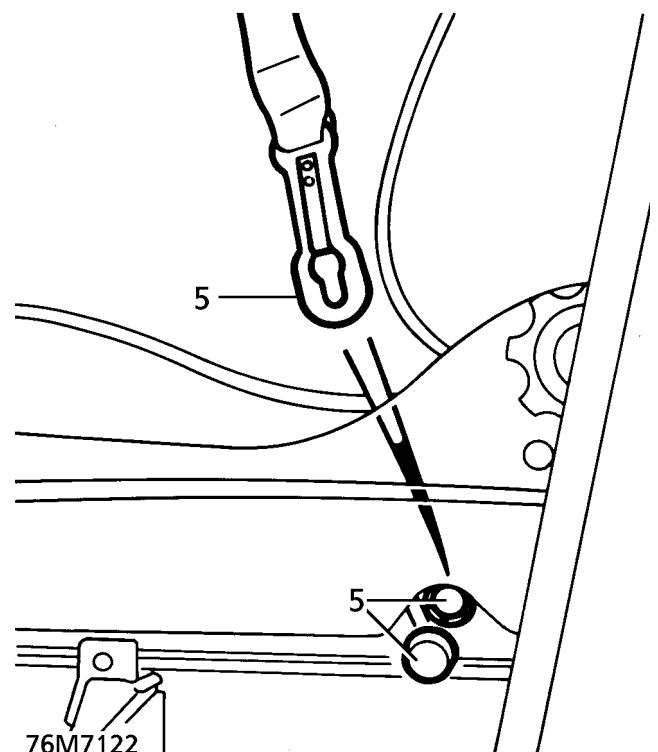



6. Remove bolt securing belt reel to 'B' post, remove belt reel.

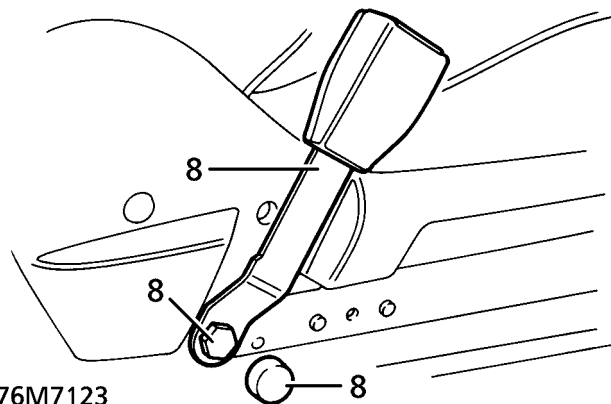
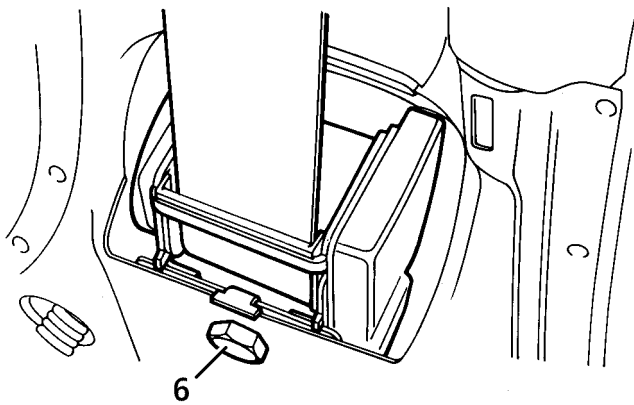

7. Move seat fully rearwards.  
8. Remove cover from seat belt stalk fixing. Remove bolt. Collect stalk.

### Refit

9. Position seat belt stalk. Secure with retaining bolt. Tighten to **35 Nm. (26 lbf.ft)**. Fit bolt cover.  
10. Fit seat belt reel to 'B' post. Secure with retaining bolt. Tighten to **35 Nm. (26 lbf.ft)**  
11. Move seat fully forwards.  
12. Secure seat belt to lower anchorage point. Fit bolt cover.



**WARNING: Ensure that belt is correctly located before fitting bolt cover.**

13. Align belt to upper anchorage point. Secure with nut. Tighten to **25 Nm. (18 lbf.ft)**. Fit cover.  
14. Secure seat belt guide to 'B' post.  
15. Refit lower 'B' post finisher.

**FRONT SEAT BELT ADJUSTABLE MOUNTING**

Service repair no - 76.73.26

**Remove**

1. Remove 'B' post trim upper.
2. Remove 2 screws securing adjustable mounting. Remove mounting.

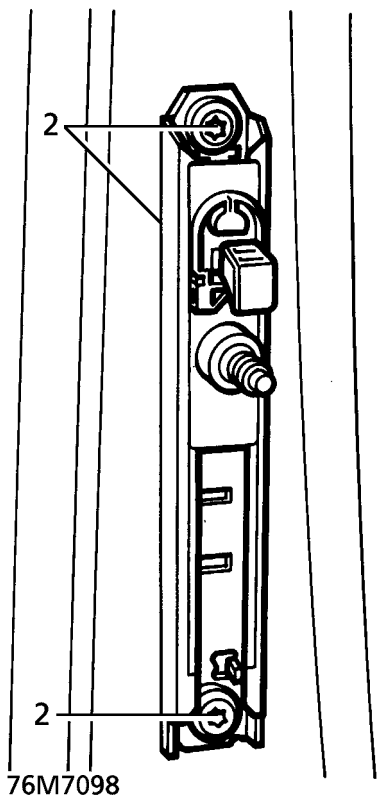
**SEAT BELT ADJUSTABLE MOUNTING - 'D' POST**

Service repair no - 76.73.36

**Remove**

1. Remove 'D' post trim - upper.
2. Remove 2 screws securing adjustable mounting. Remove mounting.

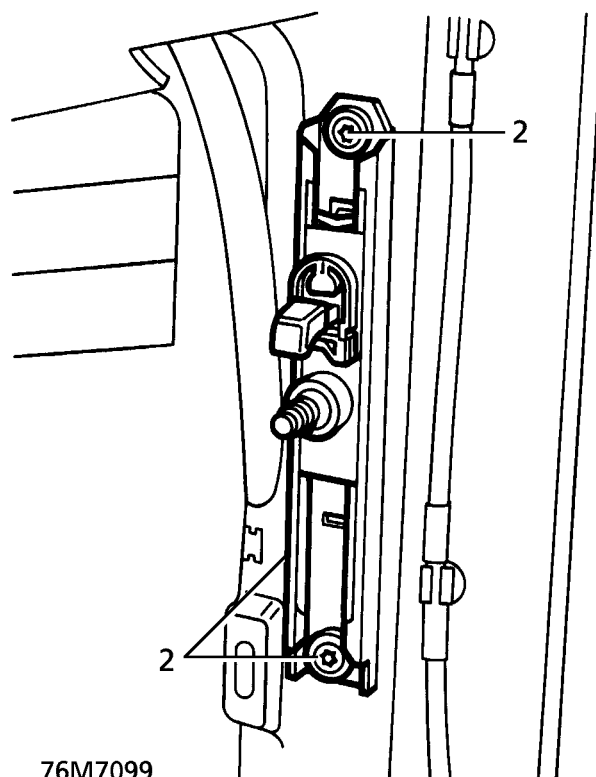
**Refit**

3. Position adjustable mounting. Secure with screws. Tighten to **25 Nm. (18 lbf.ft)**
4. Fit 'B' post trim upper.

**Refit**

3. Position adjustable mounting. Secure with screws. Tighten to **25 Nm. (18 lbf.ft)**
4. Refit 'D' post trim - upper.



## REAR SEAT BELT - CENTRE

Service repair no - 76.73.20

### Remove

1. Remove right hand rear seat. **See SEATS, Repair.**
2. Remove 3 screws securing squab hinge cover. Remove cover.

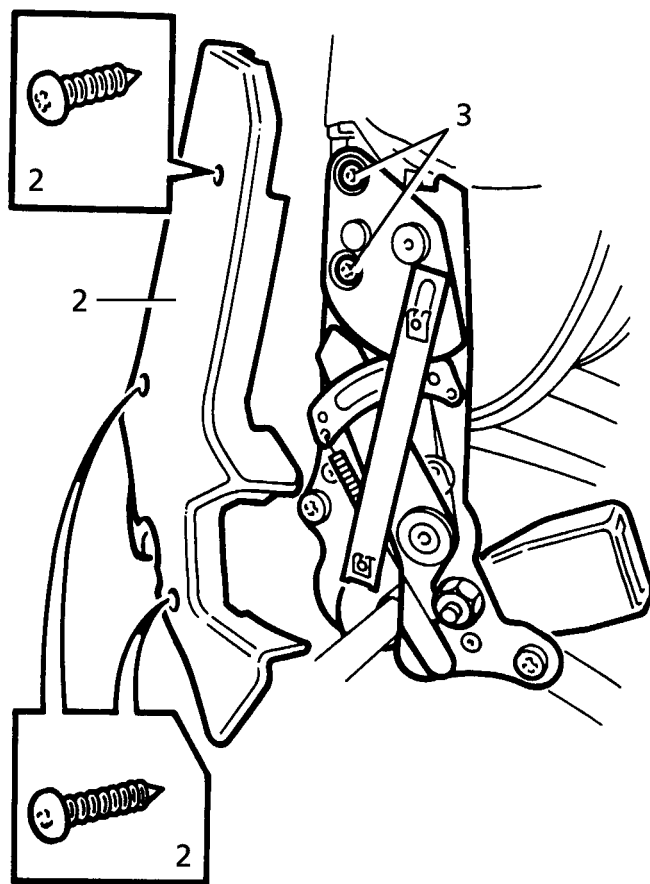

76M7114

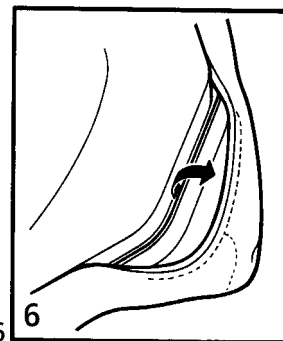
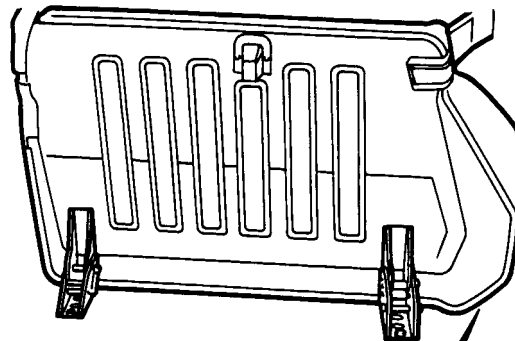

76M7126



**CAUTION:** Take care when releasing cover/foam from belt anchorage finisher.

3. Remove 2 bolts securing squab to cushion assembly.
4. Remove squab from cushion assembly.
5. Remove bolt and wave washer securing stalk to squab hinge. Remove stalk. Collect plain washer.
6. Release beaded edge of cushion cover from seat pan flange. Remove cushion cover/foam assembly.



7. Remove 3 screws securing anchorage cover to seat pan. Remove cover in 2 pieces.

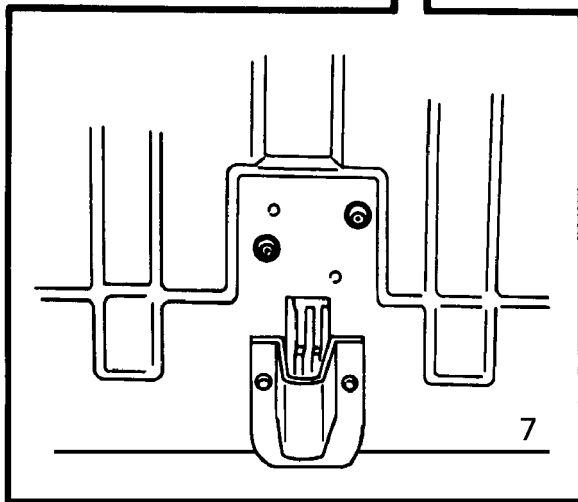
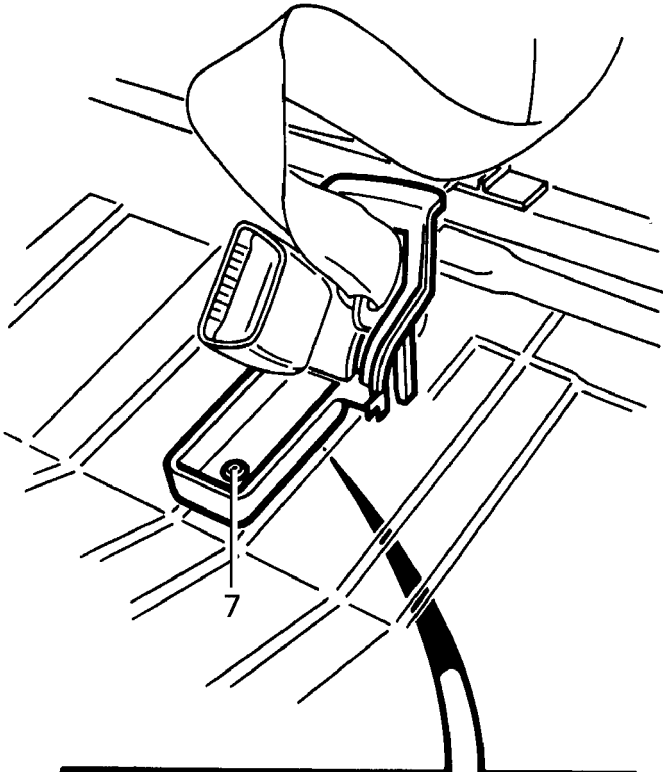

76M7115

8. Remove bolt securing seat belt to seat pan. Remove belt, collect spacer.

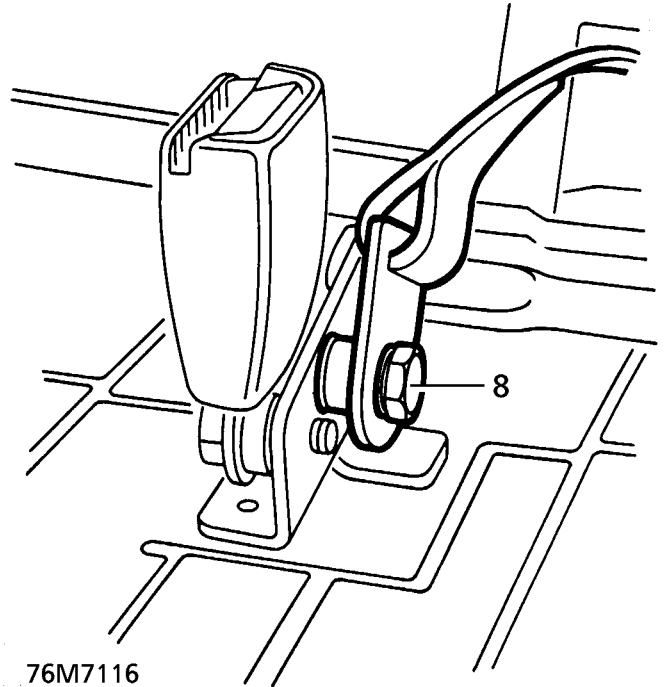

76M7116

#### Refit

9. Fit seat belt to seat pan. Secure with bolt and spacer. Tighten to **35 Nm. (26 lbf.ft)**
10. Fit seat belt anchorage cover. Secure with screws.
11. Fit cushion assembly to seat pan. Secure beaded edge of cover to seat pan flange.
12. Fit stalk to squab hinge. Secure with bolt. Tighten to **35 Nm. (26 lbf.ft)**
13. Position seat squab to cushion assembly. Secure with bolts. Tighten to **45 Nm. (33 lbf.ft)**
14. Refit squab hinge cover. Secure with screws.
15. Refit rear seat assembly. **See SEATS, Repair.**

---

**REAR SEAT BELT - LEFT HAND**

---

Service repair no - 76.73.23

**Remove**

1. Remove parcel shelf support trim. *See this section.*
2. Remove 'D' post lower trim. *See this section.*
3. Remove cover and nut securing seat belt to upper anchorage point.
4. Remove bolt securing seat belt reel.

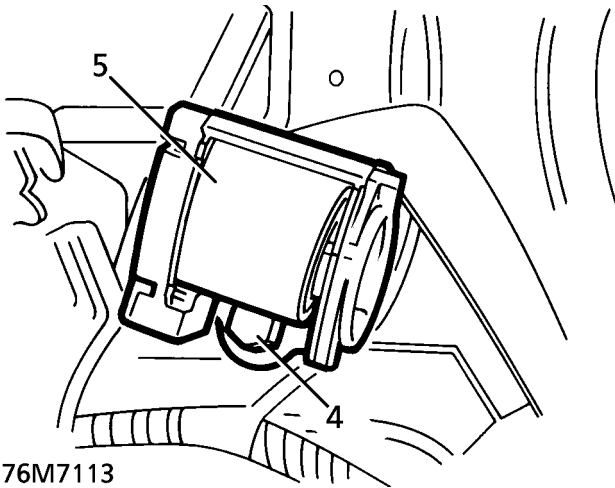

5. Remove seat belt reel.
6. Remove left hand rear seat. *See SEATS, Repair.*
7. Remove 3 screws securing squab hinge cover. Remove cover.

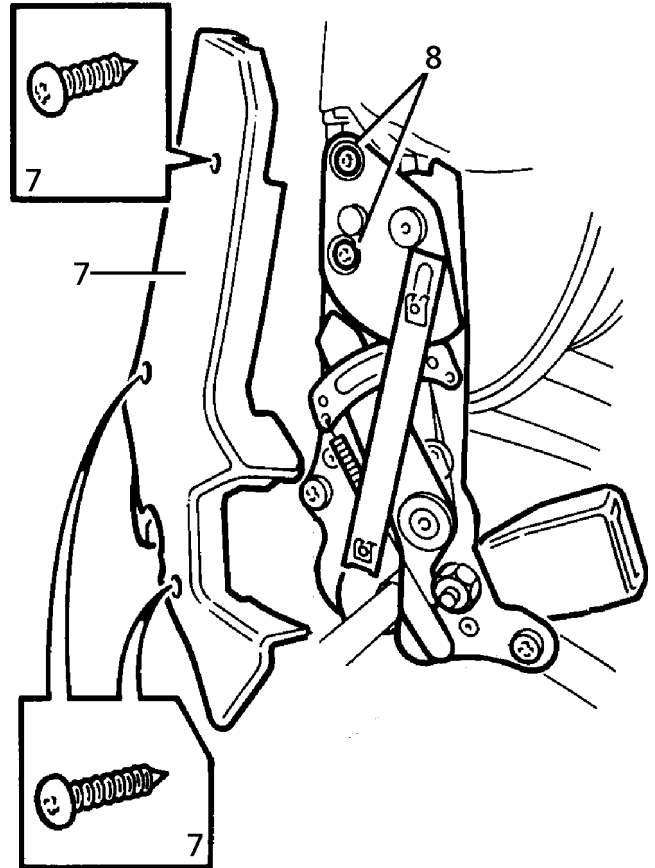

8. Remove 2 bolts securing squab to cushion assembly.
9. Remove squab from cushion assembly.
10. Remove bolt and wave washer securing stalk to squab hinge.
11. Remove stalk. Collect plain washer.

**Refit**

12. Fit stalk to squab hinge. Secure with bolt. Tighten to **35 Nm. (26 lbf.ft)**
13. Position seat squab to cushion assembly. Secure with bolts. Tighten to **45 Nm. (33 lbf.ft)**
14. Refit squab hinge cover. Secure with screws.
15. Refit rear seat assembly. *See SEATS, Repair.*
16. Position belt to upper anchorage point. Secure with nut. Tighten to **25 Nm. (18 lbf.ft)**. Fit cover.
17. Position seat belt reel. Secure with bolt. Tighten to **35 Nm. (26 lbf.ft)**
18. Fit 'D' post lower trim. *See this section.*
19. Fit parcel shelf support trim. *See this section.*

---

**REAR SEAT BELT - RIGHT HAND**

---

Service repair no - 76.73.24

**Remove**

1. Remove parcel shelf support trim. *See this section.*
2. Remove 'D' post lower trim.
3. Remove cover and nut securing seat belt to upper anchorage point.
4. Remove bolt securing seat belt reel.

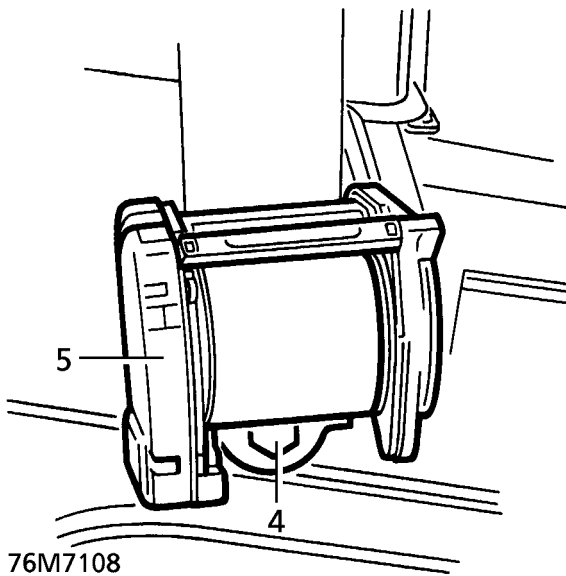

5. Remove seat belt reel.
6. Remove right hand rear seat. *See SEATS, Repair.*
7. Remove 3 screws securing squab hinge cover. Remove cover.

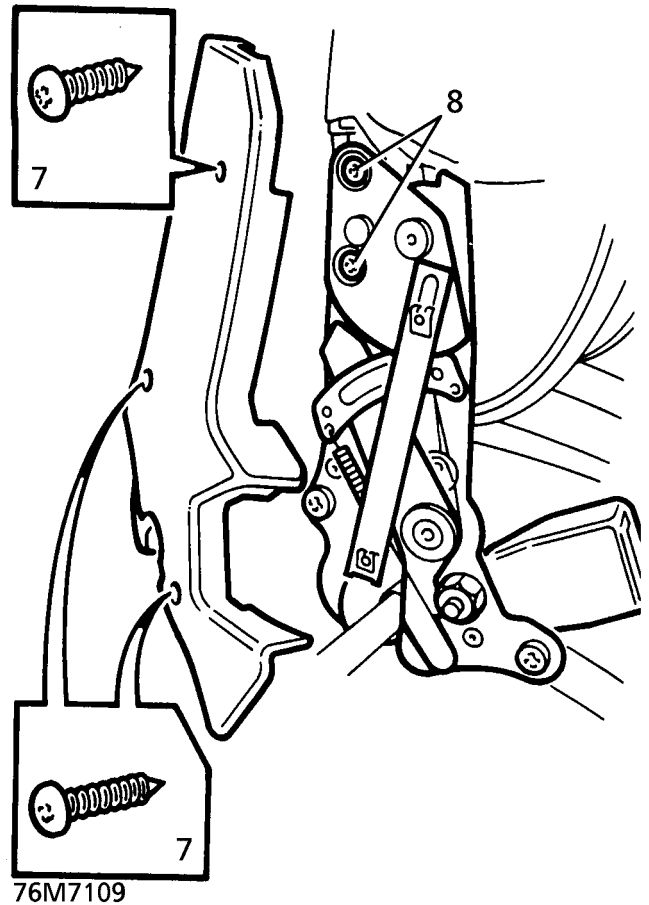

8. Remove 2 bolts securing squab to cushion assembly. Remove squab.
9. Release beaded edge of cushion cover from seat pan flange. Remove cushion cover/foam assembly.

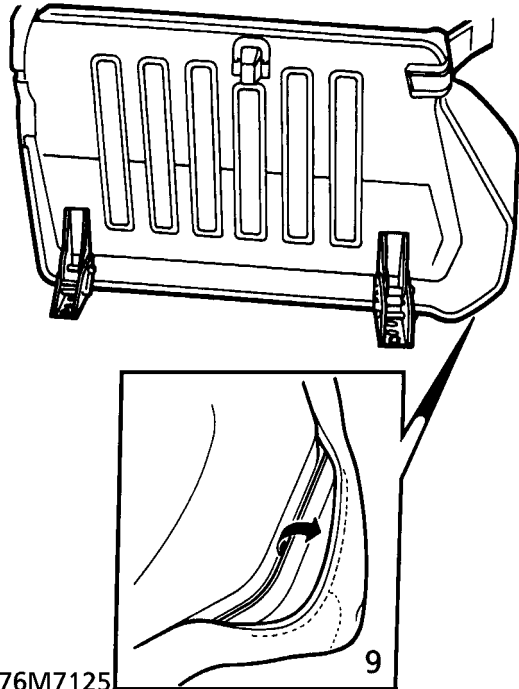

76M7125

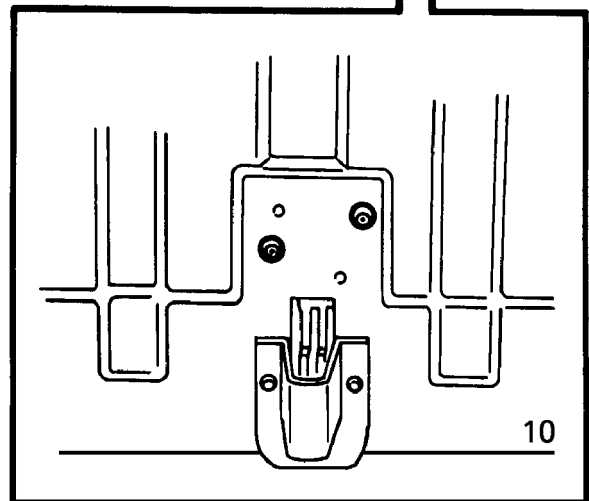
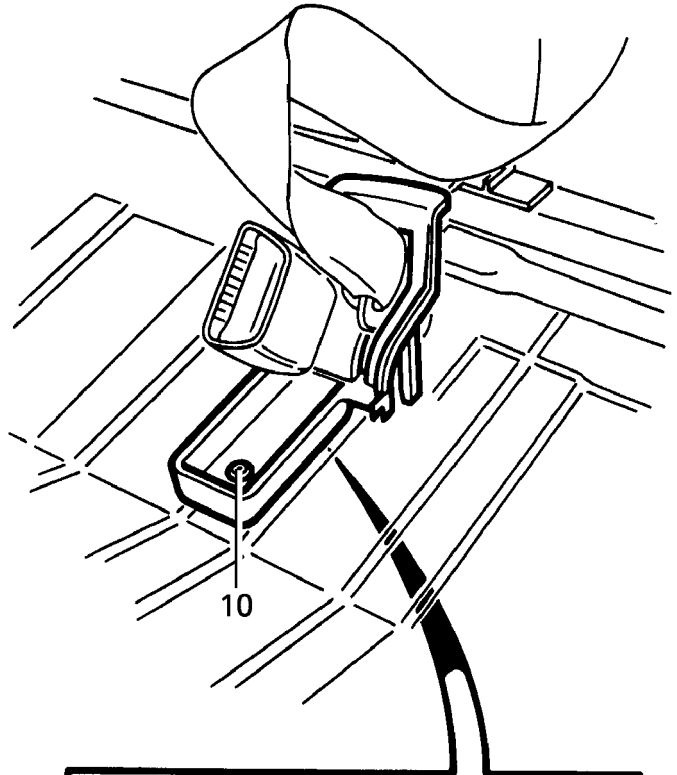

76M7110



**CAUTION:** Take care when releasing cover/foam from belt anchorage finisher.

10. Remove 3 screws securing anchorage cover to seat pan. Remove cover in 2 pieces.

11. Remove bolt securing stalk to seat pan. Remove stalk. Collect 2 spacers and wave washer.

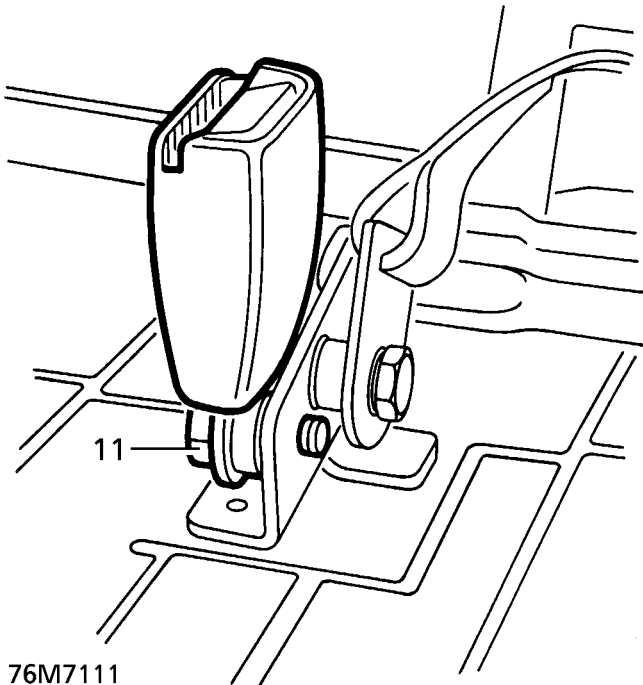

76M7111

**Refit**

12. Fit stalk to seat pan. Secure with bolt, spacers and wave washer. Tighten to **35 Nm. (26 lbf.ft)**
13. Fit seat belt anchorage cover. Secure with screws.
14. Fit cushion assembly to seat pan. Secure beaded edge of cover to seat pan flange.
15. Fit stalk to squab hinge. Secure with bolt. Tighten to **35 Nm. (26 lbf.ft)**
16. Position seat squab to cushion assembly. Secure with bolts. Tighten to **45 Nm. (33 lbf.ft)**
17. Refit squab hinge cover. Secure with screws.
18. Refit rear seat assembly. **See SEATS, Repair.**
19. Position belt to upper anchorage point. Secure with nut. Tighten to **35 Nm. (26 lbf.ft)**. Fit cover.
20. Position seat belt reel. Secure with bolt. Tighten to **35 Nm. (26 lbf.ft)**
21. Fit 'D' post lower trim.
22. Fit parcel shelf support trim. **See this section.**



---

**SLIDING ROOF - ELECTRIC**

---

Service repair no - 76.82.44

**Remove**

1. Remove headlining. *See this section.*
2. Disconnect motor multiplug.
3. Disconnect sliding roof drain tubes.
4. Remove 8 bolts securing sliding roof.
5. With assistance, remove 2 remaining bolts.  
Remove sliding roof.
6. Remove seal from sliding roof.

**Refit**

7. Ensure mating faces are clean.
8. Fit new seal to sliding roof.
9. With assistance, position sliding roof. Fit 2 bolts.
10. Fit remaining bolts.
11. Connect drain tubes. Secure with clips.
12. Connect motor multiplug.
13. Refit headlining. *See this section.*

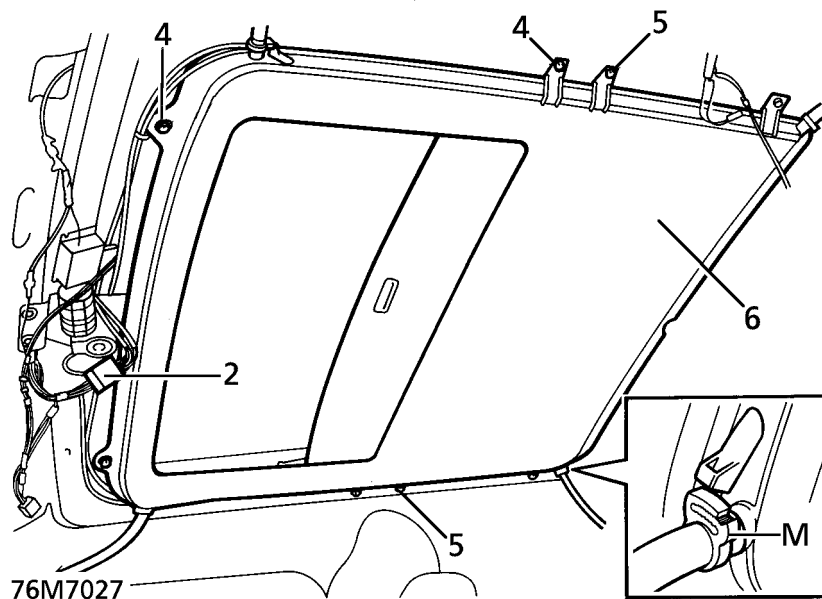

---

**HEADLINING - SLIDING ROOF**

---

Service repair no - 76.64.15

**Remove**

1. Remove upper trims from 'A', 'B', 'D' & 'E' posts.  
*See this section.*

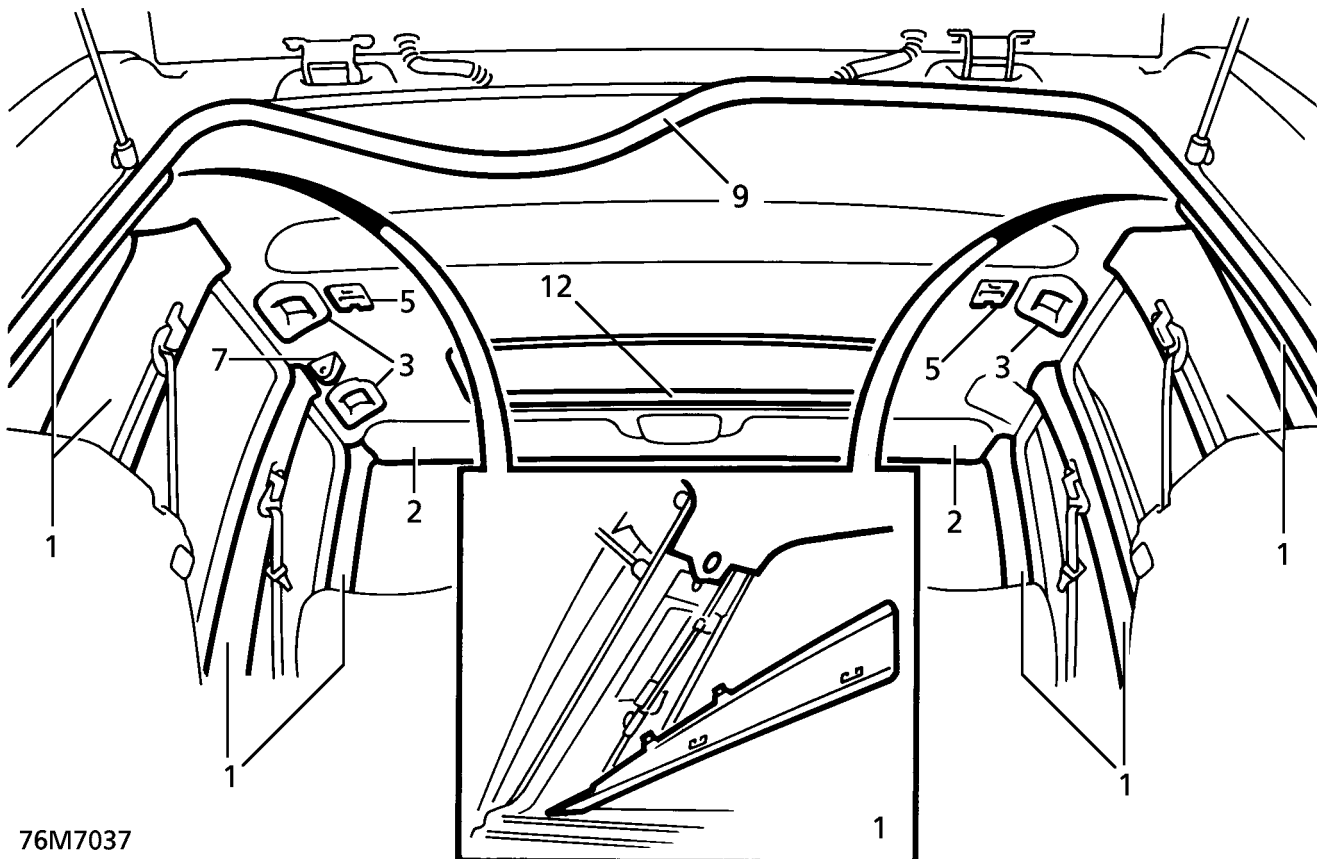

76M7037

2. Remove both sun visors. *See this section.*
3. Remove grab handles. *See this section.*
4. Remove parcel tray support trim. *See this section.*
5. Remove interior lamps. *See ELECTRICAL, Repair.*
6. Remove front courtesy lamp. *See ELECTRICAL, Repair.*
7. Remove ultrasonic sensor. *See ELECTRICAL, Repair.*
8. Fold down rear seat squabs. Recline front seat squabs.
9. Release aperture sealing rubbers at tops of doors and tailgate.
10. Release sun visor clip retaining screw cover plugs.
11. Remove sun visor retaining clip screws. Remove clips.
12. Remove sun roof aperture finisher.
13. Remove 2 headlining grab handle blanks.
14. Remove 2 studs securing rear of headlining.
15. With assistance remove headlining.

**Refit**

16. Reverse removal procedure.



## SUNROOF DRAIN TUBE - FRONT

Service repair no - 76.82.21

### Remove

1. Remove headlining. *See this section.*
2. Remove wheelarch liner. *See this section.*
3. Release drain tube from sunroof.

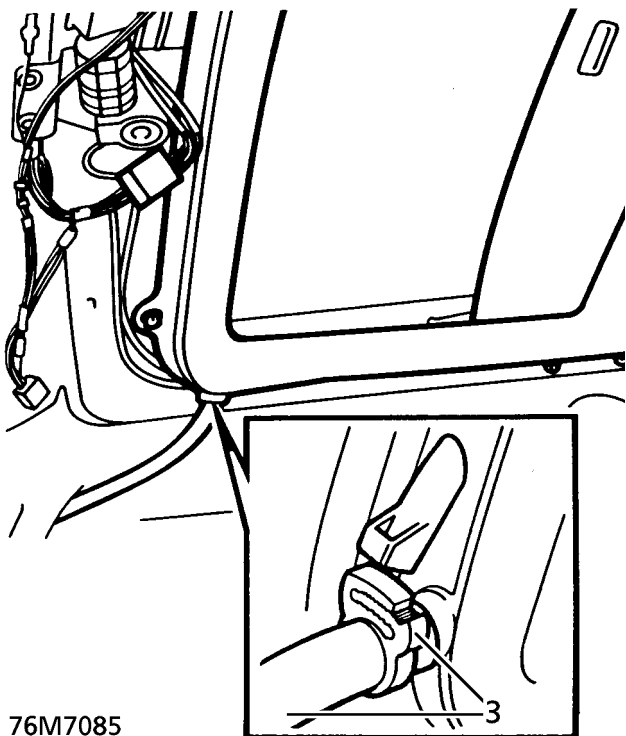

76M7085

4. Release drain tube grommet from body behind wheel arch liner.
5. Tie draw string to one end of drain tube and pull tube from 'A' post.

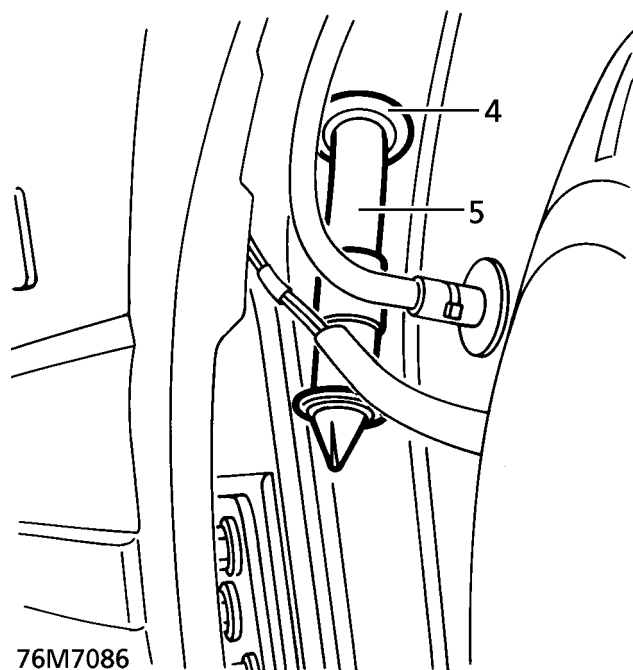

76M7086

### Refit

6. Tie draw string to new drain tube and pull through 'A' post.
7. Fit grommet to drain tube, secure to body.
8. Secure drain tube to sunroof.
9. Fit headlining. *See this section.*
10. Refit wheel arch liner. *See this section.*



---

**SUNROOF DRAIN TUBE - REAR**

---

Service repair no - 76.82.22

**Remove**

1. Remove headlining. *See this section.*



**NOTE:** Ensure that parcel shelf support panel is removed from side of drain tube to be removed.

2. Release clip from drain tube.

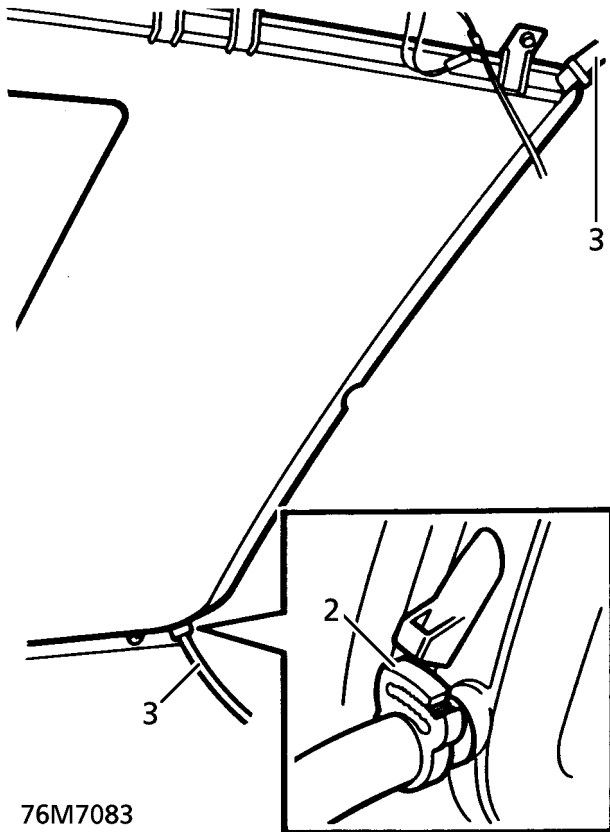

76M7083

3. Disconnect drain tube from sunroof.
4. Remove drain tube from wheel arch grommet.

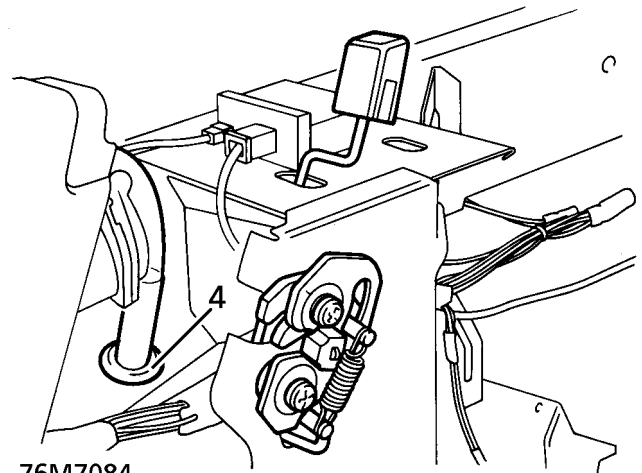

76M7084

**Refit**

5. Fit drain tube to sunroof, secure with clip.
6. Fit drain tube through wheel arch grommet.
7. Refit headlining. *See this section.*



---

**SUN VISOR**

---

Service repair no - 76.10.47

**Remove**

1. Release visor from clip.
2. Remove 3 visor retaining screws.

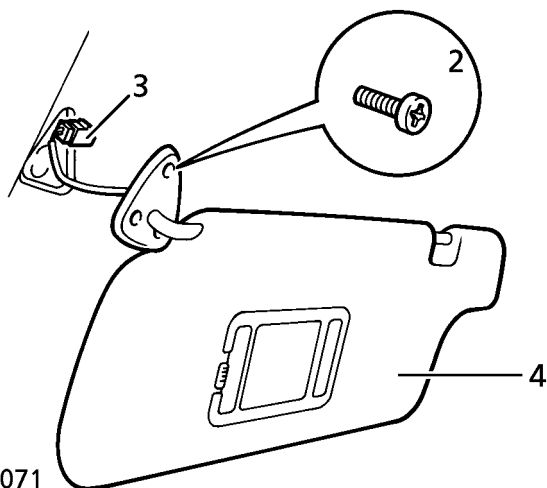

76M7071

3. Disconnect visor lamp multiplug.
4. Remove visor.
5. Remove clip if required. Carefully lever plastic tag down.

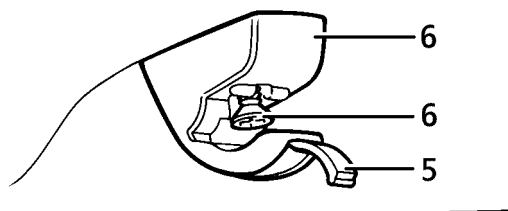

76M7072

6. Remove screw, remove clip.

**Refit**

7. Reverse removal procedure.

---

**SILL FINISHER**

---

Service repair no - 76.43.84

**Remove**

1. Remove 3 screws securing front tread plate.
2. Remove 2 screws securing rear tread plate.
3. Remove trim stud securing rear of sill finisher.
4. Release 8 clips securing finisher to sill.
5. Remove sill finisher.

**Refit**

6. Renew clips as necessary.
7. Reverse removal procedure.

**TAILGATE - UPPER**

Service repair no - 76.28.29

**Remove**

1. Remove both 'E' post finishers.
2. Remove 2 trim fixing studs. Release headlining from 'E' posts.

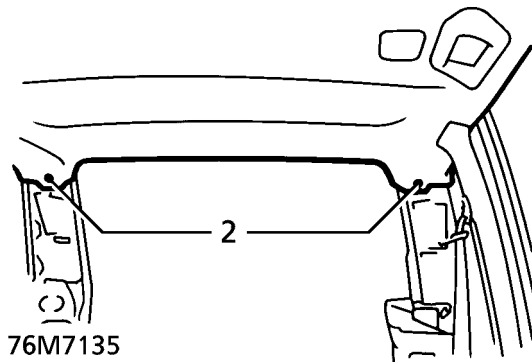

3. Release 4 turn buckles securing access panel to LH side load space trim. Remove panel.
4. Locate rear screen washer non-return valve. Disconnect tailgate feed tube from valve.

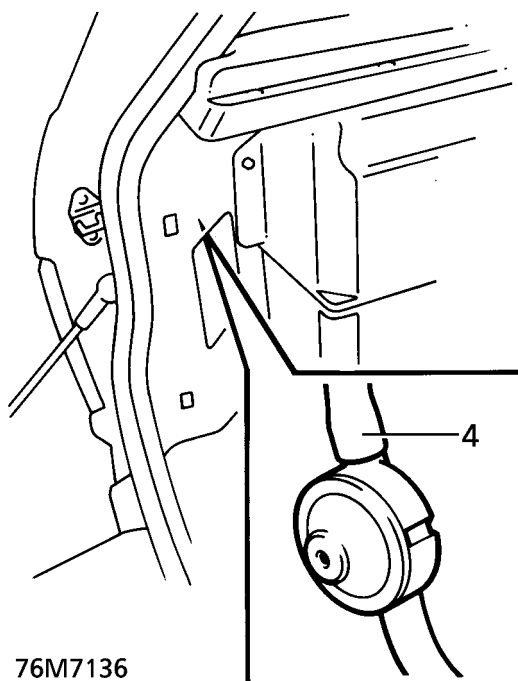

5. Attach draw string to tube to aid re-assembly.
6. Release tailgate harness protective sleeve from roof panel.

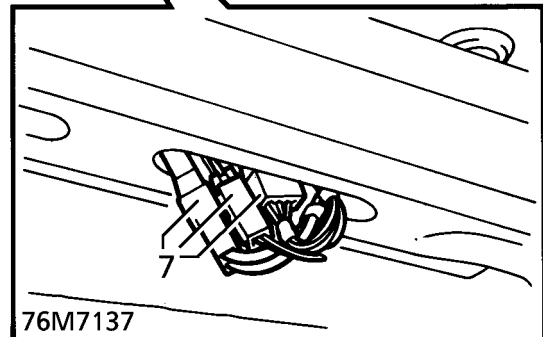
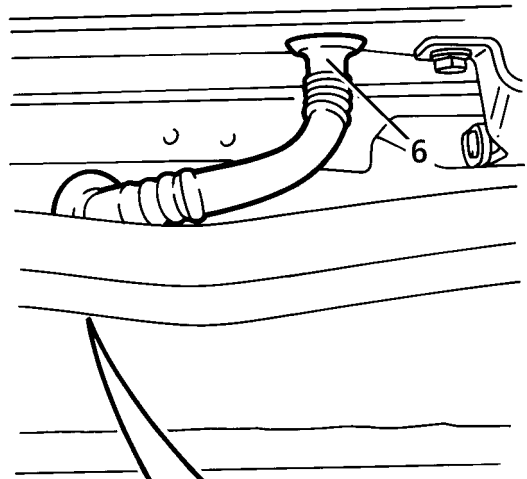

7. Disconnect 3 tailgate harness multiplugs from body harness. Pull plugs out through hole in roof panel.
8. Pull screen washer tube out through hole in roof panel. Disconnect draw string.
9. Mark outline of hinge on tailgate to aid re-assembly.
10. Apply protective tape to roof panel before releasing tailgate.
11. With assistance, disconnect gas struts from tailgate.
12. With assistance, remove 4 bolts securing hinges to tailgate. Remove tailgate.



## Refit

13. With assistance, position tailgate to hinges. Align marks. Secure with bolts. Tighten to **25 Nm. (18 lbf.ft)**
14. With assistance, connect gas struts to tailgate.
15. Remove protective tape from roof panel.
16. Attach draw string to washer tube. Pull tube along roof into position at 'E' post. Remove draw string.
17. Connect tube to non-return valve.
18. Feed 3 tailgate harness multiplugs through roof panel. Connect to body harness.
19. Secure tailgate harness protective sleeve to roof panel.
20. Reposition headlining at 'E' posts. Secure with studs.
21. Fit load space access panel. Secure with turn buckles.
22. Fit both 'E' post finishers.

## Adjust

23. Check alignment of lower tailgate. **See this section.**
24. Align tailgate to aperture by adjusting position of hinges on tailgate or body.
25. Align tailgate to adjacent body panels by adjusting position of hinges on body.



**NOTE: To prevent wind noise, ensure top edge of tailgate does not stand proud of roof panel.**

## TAILGATE - LOWER

Service repair no - 76.28.30

### Remove

1. Remove parcel tray support trim from RH side of luggage area. **See this section.**
2. Disconnect tailgate harness multiplug from body harness. Release grommet from lower of 'E' post. Pull harness from body.

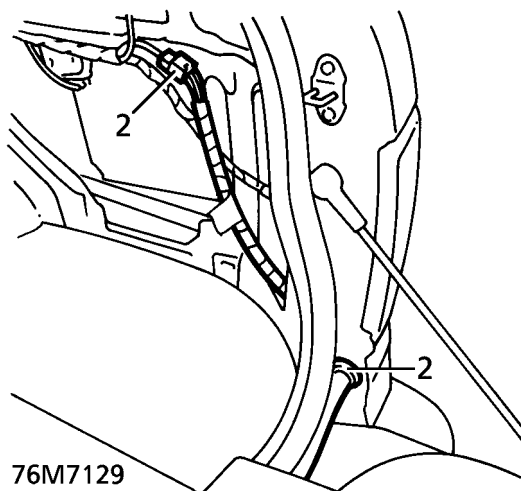

3. Fit protection under tailgate.
4. Mark outline of hinges to body to aid reassembly.
5. Remove bolt securing each check strap to body. Collect spacer and fibre sealing washer.

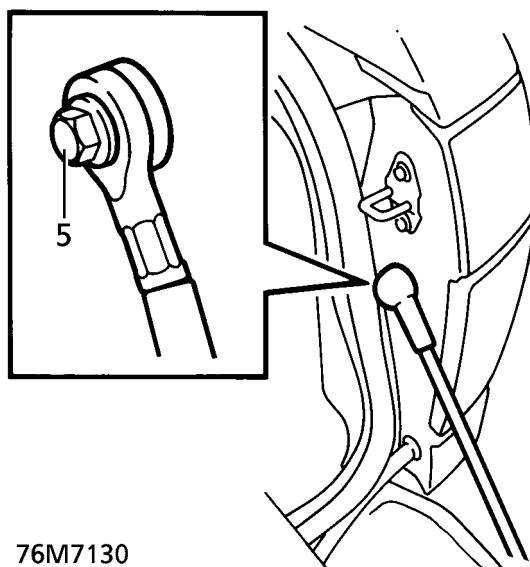

- With assistance, remove bolts securing tailgate hinges to body. Remove tailgate complete with hinges.

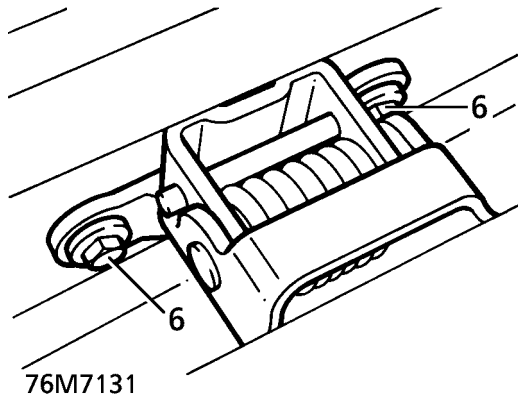

#### Refit

- With assistance, position tailgate to body. Secure with bolts. Tighten to **25 Nm. (18 lbf.ft)**
- Position support stays with spacer and sealing washer next to body. Tighten to **22 Nm. (16 lbf.ft)**
- Remove protection.
- Feed tailgate harness into 'E' post. Connect multiplug to body harness.
- Fit harness grommet to 'E' post.
- Fit parcel tray support trim. **See this section.**

#### Adjust

- Align tailgate to aperture by adjusting position of hinges on tailgate or body.
- Align tailgate to adjacent body panels by adjusting position of hinge to tailgate.
- When tailgate alignment is correct, adjust height and inboard/outboard position of each striker. Tighten striker bolts. Check for correct latching.
- Slacken bolts, re-adjust striker positions as necessary. Tighten to **8 Nm. (6 lbf.ft)**

#### TAILGATE STRIKER

Service repair no - 76.37.26

#### Remove

- Remove 2 bolts securing striker. Remove striker.

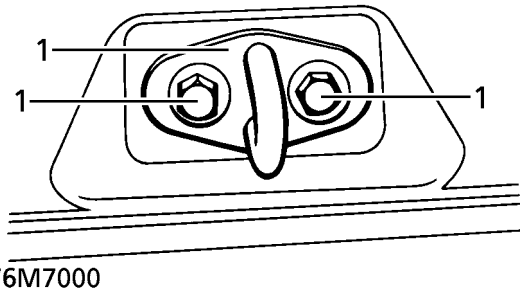

#### Refit

- Position striker. Secure with bolts
- Close tailgate. Check alignment.
- If necessary, open tailgate, slacken bolts, realign striker. Re-tighten bolts.



## TAILGATE LATCH

Service repair no - 76.37.17

### Remove

1. Release studs securing tailgate board. Remove board.

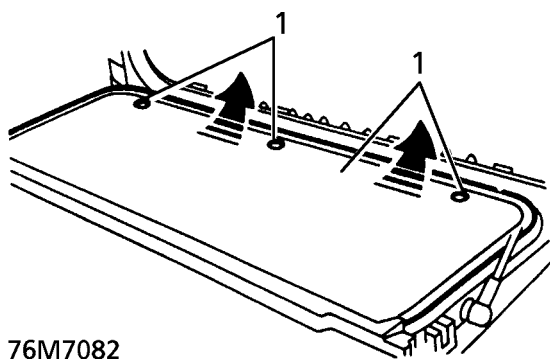

76M7082

2. Release clips securing operating rods to tailgate centre latch. Release rods.

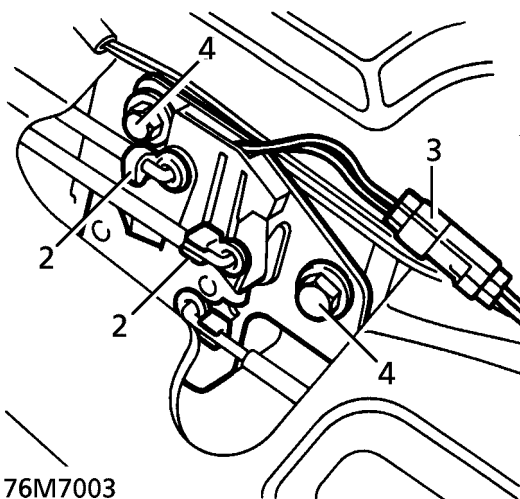

76M7003

3. Disconnect latch multiplug.
4. Remove 2 bolts securing latch to tailgate. Remove latch.

### Refit

5. Reverse removal procedure.

## TAILGATE LATCH - OUTER

Service repair no - 76.37.73

### Remove

1. Release studs securing tailgate board. Remove board.

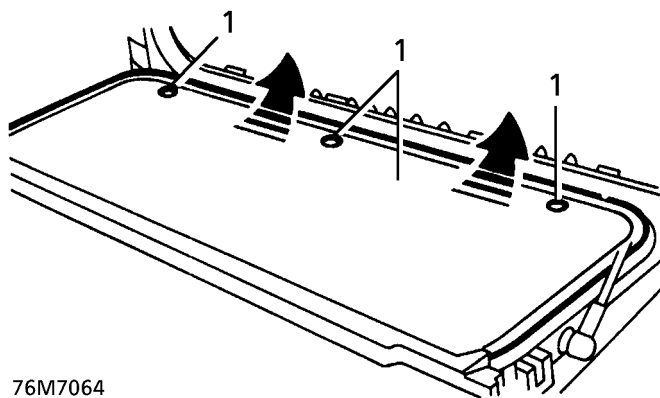

76M7064

2. Release clip securing outer latch rod. Disconnect rod from centre latch.

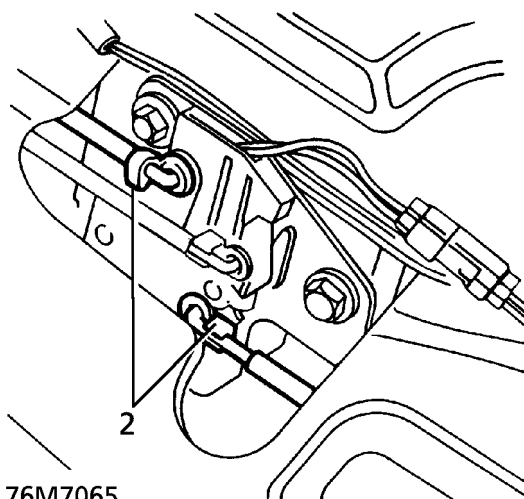

76M7065

- Remove 2 bolts securing outer latch to tailgate.  
Remove latch and rod.

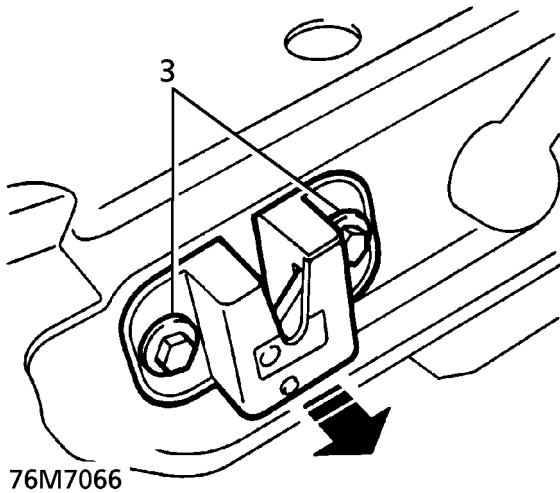

- Rotate release rod 90° to remove from outer latch.

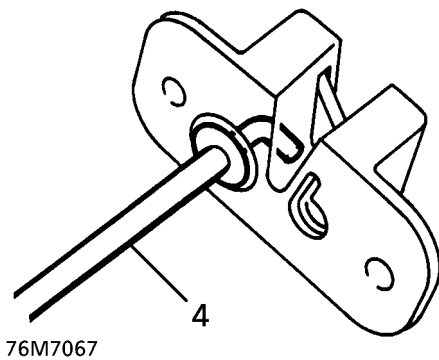

#### Refit

- Reverse removal procedure.

#### UPPER TAILGATE - INTERIOR TRIM

Service repair no - 76.34.13

#### Remove

##### Lower trim assembly

- Release load space lamp from trim panel, disconnect 2 Lucar terminals and remove lamp.
- Remove 6 screws securing trim panel to side trims and tailgate.

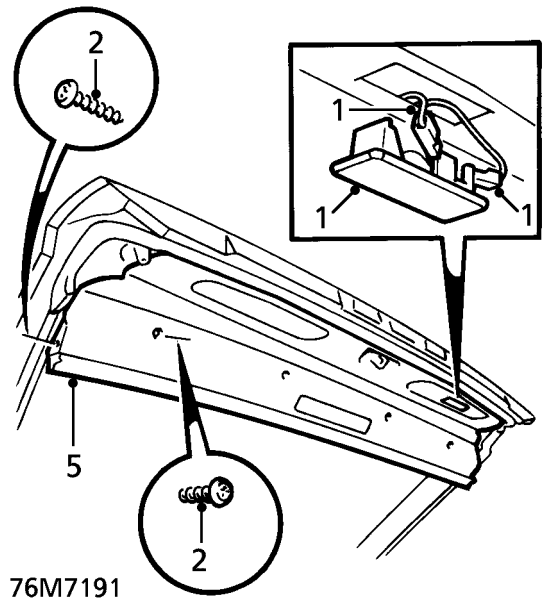

- Release 4 studs securing trim panel to tailgate.
- Disconnect high level stop lamp multiplug, if fitted.
- Remove lower trim assembly.

##### Upper trim

- Remove 6 screws securing trim panel to tailgate.

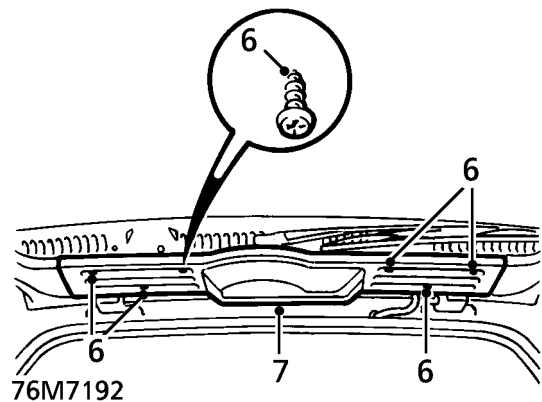



- Remove trim panel and collect 2 foam pads.

#### Side trims

- Release 3 studs securing each side trim.

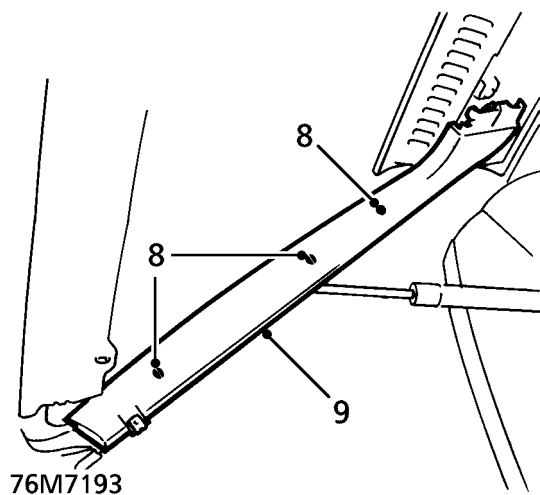

- Remove 2 side trims.

#### Refit

- Reverse removal procedure.

#### TAILGATE STRUT

Service repair no - 76.40.33

#### Remove

- Secure tailgate in open position using suitable support.
- Release clips securing strut to ball joints. Remove strut.

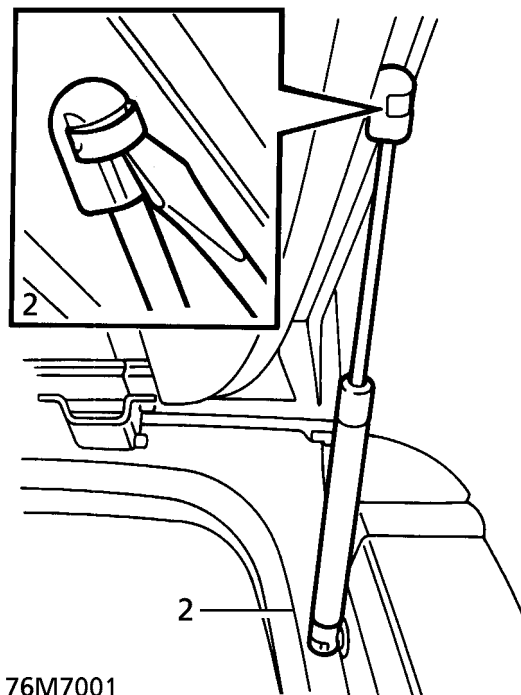

#### Refit

- Reverse removal procedure.



**WHEEL ARCH LINER - FRONT**

Service repair no - 76.10.48

**Remove**

1. Raise the vehicle.

**WARNING: Support on safety stands.**

2. Remove relevant road wheel.
3. Remove 3 screws securing mud flap. Remove mud flap.
4. Remove 8 studs securing wheel arch liner.

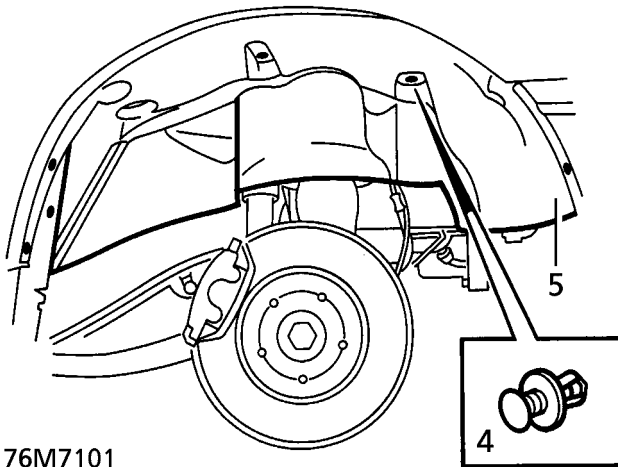

76M7101

**Refit**

5. Position liner and secure with trim studs.
6. Fit mud flap and secure with screws.
7. Refit road wheel. Secure with nuts. Tighten to **108 Nm. (80 lbf.ft)**
8. Remove safety stands. Lower vehicle.

**WHEEL ARCH LINER - REAR**

Service repair no - 76.10.49

**Remove**

1. Raise the vehicle.

**WARNING: Support on safety stands.**

2. Remove relevant road wheel.
3. Remove screws from wheel arch liner fixings. Remove fixings.

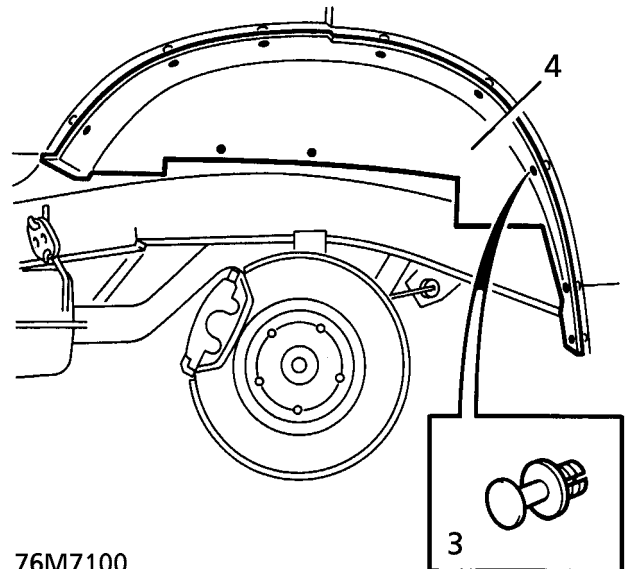

76M7100

4. Remove liner.

**Refit**

5. Position liner. Fit liner fixings. Secure with screws.
6. Refit road wheel. Secure with nuts. Tighten to **108 Nm. (80 lbf.ft)**
7. Remove safety stands. Lower vehicle.



## WINDSCREEN

Service repair no - 76.81.01



**NOTE:** The following equipment is required:

masking tape;  
sharp knife;  
reciprocating blade, powered cutting knife\*, or cutting wire and handles;  
suction lifters;  
windscreen repair kit;  
sealer applicator gun.

\* A reciprocating blade cutting tool, such as 'FEIN Special Cutter', is recommended for this operation. A flat blade, with an effective length of at least 25mm and a 'U' shaped blade of at least 30mm is required.



**CAUTION:** Extreme care is necessary to ensure that paintwork and trim does not become damaged during the removal process.

Particular care should be taken when using cutting wire and handles to avoid damage to seal along leading edge of fascia.



**WARNING:** Wear protective gloves when handling glass, solvents and primers.

## Remove

1. Remove interior mirror. *See this section.*
2. Remove plenum panels. *See HEATING AND VENTILATION, Repair.*

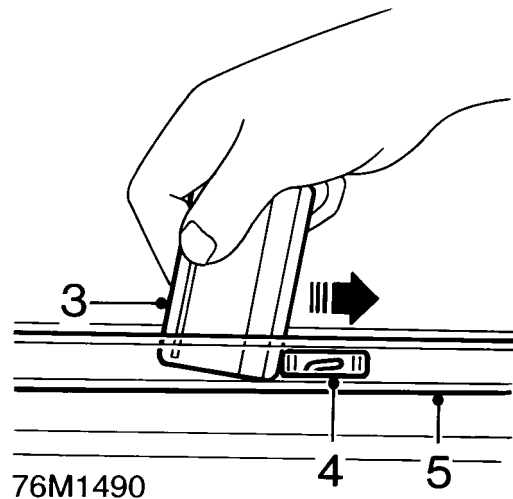

3. Insert a thin plastic strip, such as a credit card, between windscreen upper finisher and roof panel.
4. Disengage 8 clips securing upper finisher by sliding clips towards left hand side of vehicle.
5. Remove upper screen finisher.

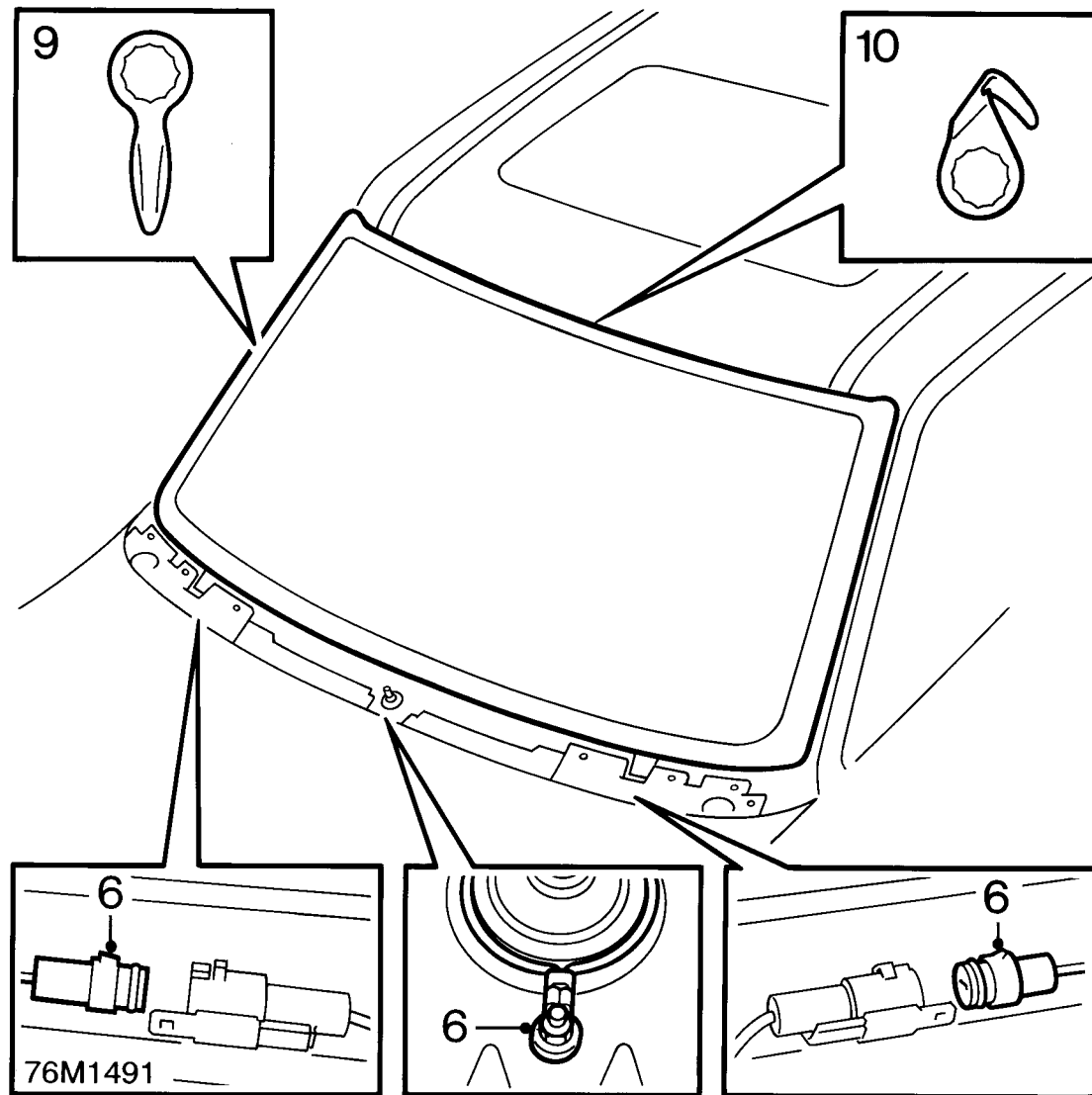

6. If fitted, disconnect heating element multiplugs. Disconnect heating element earth wire. Tape heater connections onto windscreen to prevent fouling during removal procedure.
7. Mask around windscreen aperture to protect paintwork.
8. Fit protective cover over fascia and bonnet.

#### Removal Using Reciprocating Blade Tool

9. Cut through P.U. adhesive along sides of screen using flat blade.
10. Using a 'U' shaped blade, cut through adhesive bead along upper and lower edges of screen.



**CAUTION:** Access to adhesive around lower screen supports is restricted. Manoeuvre blade to cut as much sealant from around screen supports as possible.

11. Attach suction lifters to glass. With assistance, cut through remaining sealant around screen supports using a sharp knife.
12. With assistance, remove windscreen glass.

#### Removal Using Cutting Wire and Handles.

13. Remove both 'A' post finishers. *See this section.*
14. Remove both sun visors. *See this section.*
15. Remove map/courtesy lamp assembly. *See ELECTRICAL, Repair.*

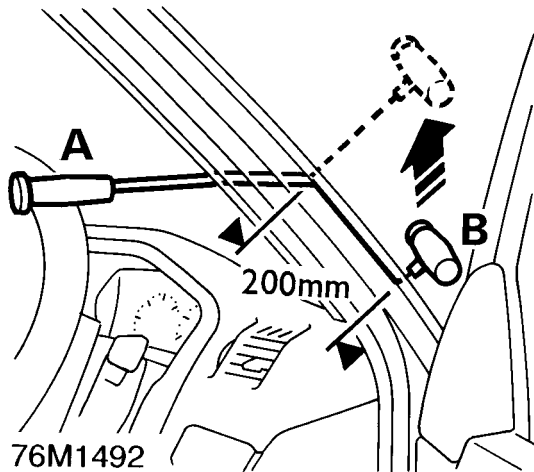
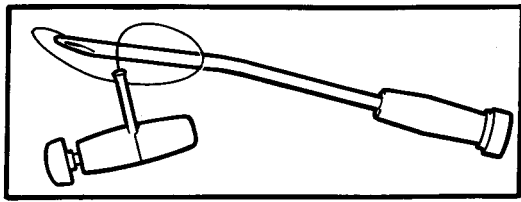

76M1492

**Refit**

21. carefully cut old sealer from body flange to obtain a smooth surface, approximately 2 mm (1/16 in) thick.



**CAUTION: Do not cut down to painted surface.**

22. Inspect supports, renew if damaged.
23. Position screen on felt covered surface.
24. If original screen is to be refitted, cut old sealer from glass to obtain a smooth surface, approximately 2 mm (1/16 in) thick.

16. Mask along leading edge of headlining.
17. Using a sharp knife, cut through P.U. sealer at side of screen, towards lower corner.
18. Insert cutting wire through knife cut and fit handles, as shown, with approximately 200 mm (8 in) of wire between handles.
19. With assistance, wedge tube of handle 'A' between glass and body, ahead of the cutting position, and carefully cut the sealer using a continuous pull on handle 'B' from the outside. Cut side and top edges first. Attach suction lifters and restrain glass as last of sealant is cut.



**NOTE: When cutting along lower edge, manoeuvre wire between glass edge and screen supports to reduce strain on wire.**

20. Attach suction lifters to glass. With assistance, remove windscreen.

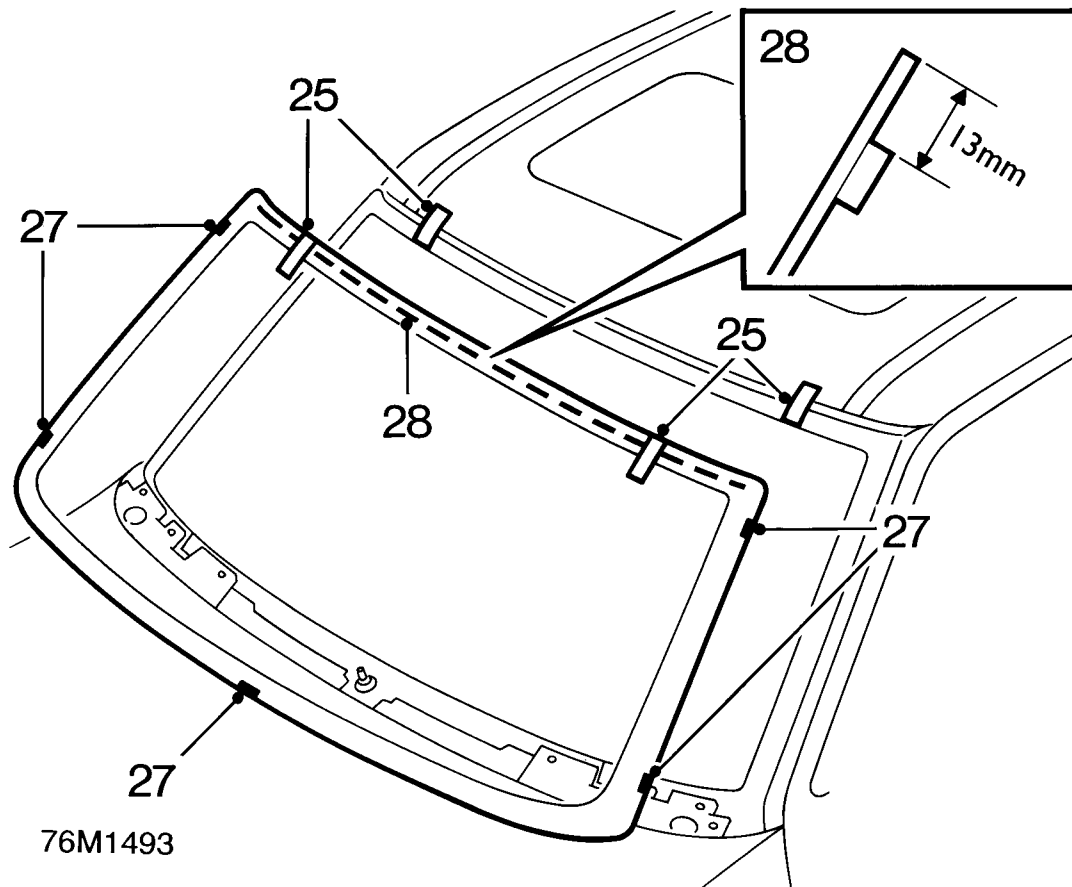

**CAUTION: Do not cut down to surface of glass.**

25. Position and centralise new windscreen to body. Apply tape reference marks to aid final fitment. Remove screen and position to work surface.
26. Apply cleaning solvent to sealing surface of glass and body flange.



**CAUTION: Do not touch cleaned or primed areas with fingers.**

27. Position 5 screen spacer blocks on inside edge of glass, over cut-out marks in obscuration band.
28. If necessary, peel off backing strip and stick foam glazing dam along inside surface of glass, approximately 13 mm (1/2 in) from top edge.

29. Shake primer tins for at least 30 seconds. Apply body primer to sealing surface of body flange using supplied applicator.
30. Apply glass primer to sealing surface of glass.



**CAUTION: Use a separate applicator for each primer.**

31. Remove lid from sealer cartridge, remove crystals, pierce membrane and fit pre-cut nozzle. Fit cartridge to applicator gun.



**NOTE: The profile of the nozzle must be modified slightly to produce the required bead section.**

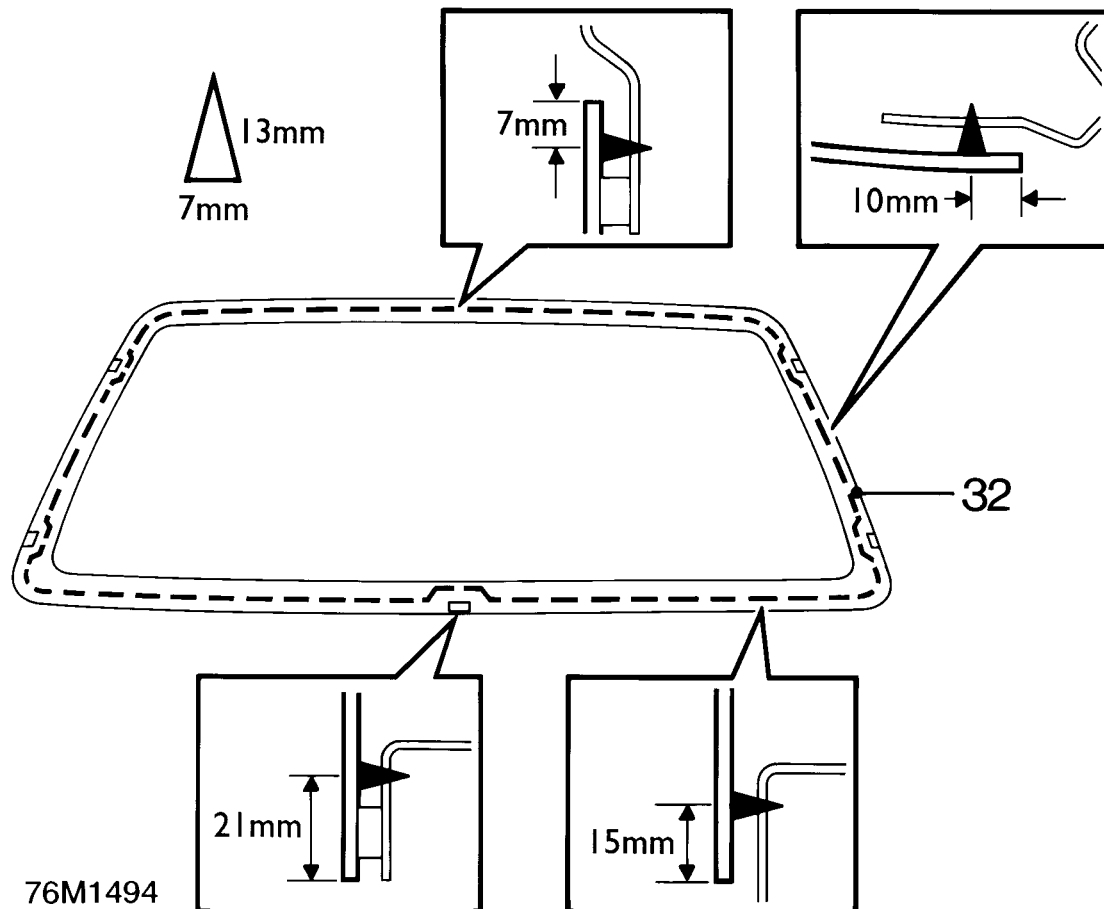

- 32. Apply a continuous bead of sealer to windscreen as shown.
- 33. Fit suction lifters to glass.
- 34. With assistance, position glass centrally, using previously made tape markings and lower onto supports. Seat glass to spacer blocks.



**CAUTION: Do not apply heavy pressure to the sides of the screen. Lightly press screen from centre outwards until edges are to required gap. Pushing screen edges into position can bend screen and lead to cracking in service.**

- 35. Remove protection from fascia and bonnet.
- 36. Remove masking tape.
- 37. If fitted, connect heating element multiplugs and earth wire.
- 38. Remove clips from upper screen finisher.
- 39. Fit clips to body studs. Position upper screen finisher and engage to clips.

- 40. Fit plenum panels. *See HEATING AND VENTILATION, Repair.*
- 41. Fit interior mirror. *See this section.*

#### If Cutting Wire and Handles Used

- 42. Remove masking from leading edge of headlining.
- 43. Fit map/courtesy lamp assembly. *See ELECTRICAL, Repair.*
- 44. Fit sun visors. *See this section.*
- 45. Fit 'A' post finishers. *See this section.*



**CAUTION: A curing time of 6 hours is recommended. During this time, leave the windows open and DO NOT slam the doors.**

**WINDSCREEN LOWER FINISHER**

Service repair no - 76.43.41

**Remove**

1. Remove both windscreen side finishers. **See this section.**
2. Remove both windscreen wiper arms. **See WIPERS AND WASHERS, Repair.**
3. Release 10 clips securing windscreen lower finisher.

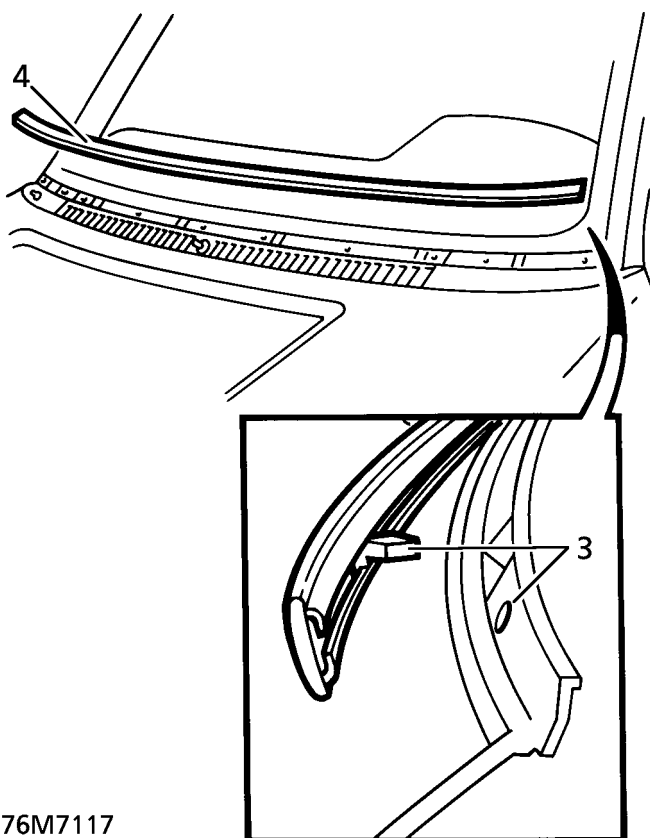

76M7117

4. Remove windscreen lower finisher.

**Refit**

5. Reverse removal procedure.

**WINDSCREEN SIDE FINISHER**

Service repair no - 76.43.39

**Remove**

1. Lift side finisher seal to reveal fixings.
2. Remove 4 screws securing side finisher.

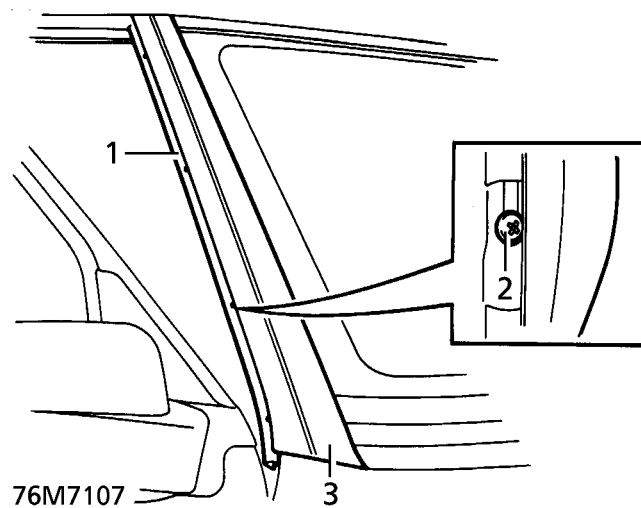

3. Remove side finisher.

**Refit**

4. Position side finisher. Secure side with screws.



## BACKLIGHT GLASS

Service repair no - 76.81.10



**NOTE:** The following equipment is required:

masking tape.  
Sharp knife.  
Cutting wire and handles, or a reciprocating blade, powered cutting knife\*.  
Suction lifters.  
Windscreen repair kit.  
Sealer applicator gun.

\*A reciprocating blade cutting tool, such as 'FEIN Special Cutter' is recommended for this operation. A flat blade, with an effective length of at least 25mm and a 'U' shaped blade of at least 30mm are required.



**WARNING:** Wear protective gloves when handling glass, solvents and primers.

### Remove

1. Remove interior trim from tailgate, **See this section.**
2. Release backlight lower finisher from 7 clips.
3. Remove backlight lower finisher.

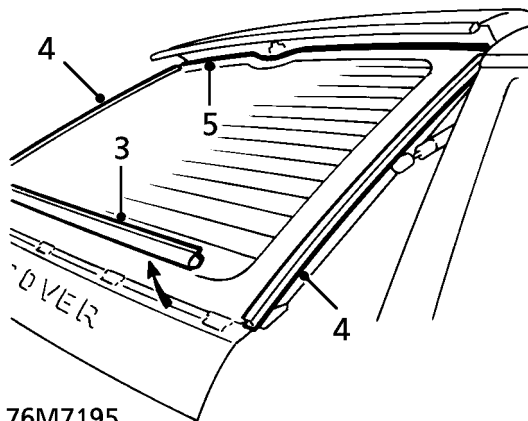

4. Remove backlight side finishers.



**NOTE:** Side finishers are secured to backlight with P.U. sealer. New backlight glasses are supplied with side finishers fitted. Side finishers are available separately if original glass is to be refitted.

5. Remove rubber finisher from upper edge of backlight glass.

6. Protect tailgate panel with masking tape.
7. Disconnect two Lucar terminals from screen heater element.

### Removal Using Reciprocating Blade Tool

8. Cut through P.U. adhesive along sides of screen using flat blade.

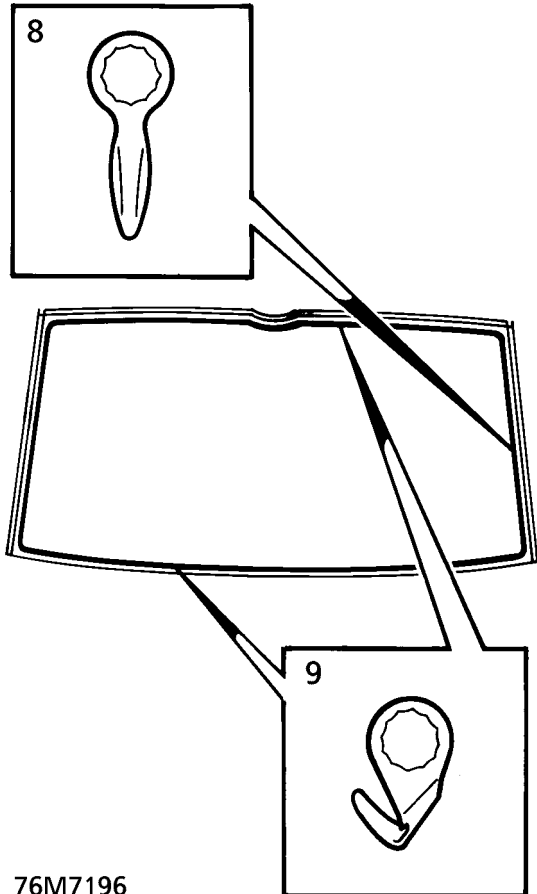

9. Using a 'U' shaped blade, cut through adhesive bead along upper and lower edges of glass.



**CAUTION:** Access around lower clips is restricted. Manoeuvre blade to cut through as much adhesive as possible.

10. Attach suction lifters to glass. With assistance, cut through remaining sealant around lower clips.
11. With assistance, remove backlight glass.



### Removal Using Cutting Wire Handles

12. Using a sharp knife, cut through P.U. sealer at side of backlight.
13. Insert cutting wire through knife cut and fit handles, as shown, with approximately 200mm of wire between handles.

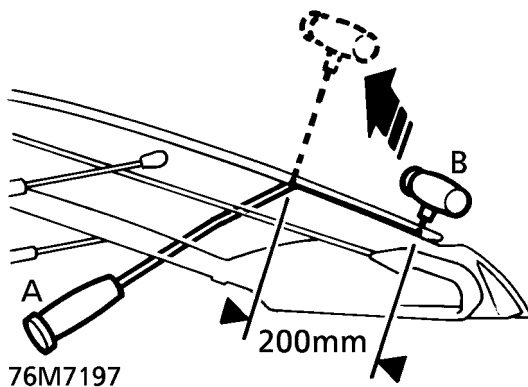
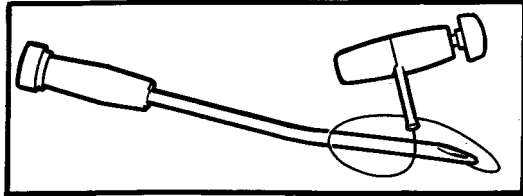

14. With assistance, wedge tube of handle 'A' between glass and body, ahead of the cutting position, and carefully cut the sealer using a continuous pull on handle 'B' from the outside. Cut side and top edges first. Attach suction lifters and restrain glass as last of sealant is cut.



**NOTE: When cutting along lower edge, manoeuvre wire between glass edge and finisher clips to reduce strain on wire.**

15. With assistance, remove backlight glass.

### Refit

16. Carefully cut old sealer from body flange to obtain a smooth surface, approximately 2mm thick.



**CAUTION: Do not cut down to painted surface.**

17. Renew broken finisher clips as necessary. Position finisher clips centrally on tailgate studs.



**NOTE: Clips control height and seating of lower glass edge.**

18. Position and centralize new backlight to tailgate. Apply tape reference mark to aid final fitment.

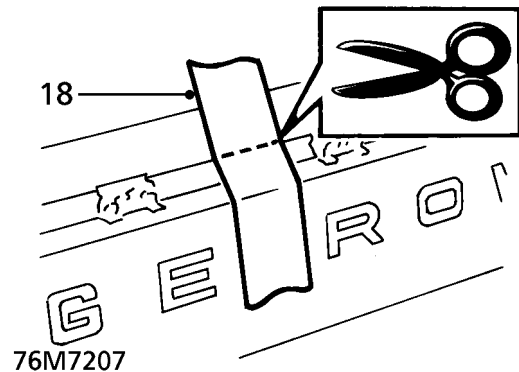

19. Position new backlight on felt covered surface.
20. Fit and centralize rubber finisher to top of glass.



**NOTE: Finisher controls seating depth of glass top edge.**

21. Apply cleaning solvent to sealing surface of glass and body flange.



**CAUTION: Do not touch cleaned or primed areas with fingers.**

22. Shake primer tins for at least 30 seconds. Apply body primer to sealing surface of body flange using supplied applicator.
23. Apply glass primer to sealing surface of glass.



**CAUTION: Use a separate applicator for each primer.**

24. Remove lid from sealer cartridge, remove crystals, pierce membrane and fit pre-cut nozzle. Fit cartridge to applicator gun.



**NOTE: The profile of the nozzle must be modified slightly to produce the required bead section.**



25. Apply a continuous bead of sealer to backlight as shown.

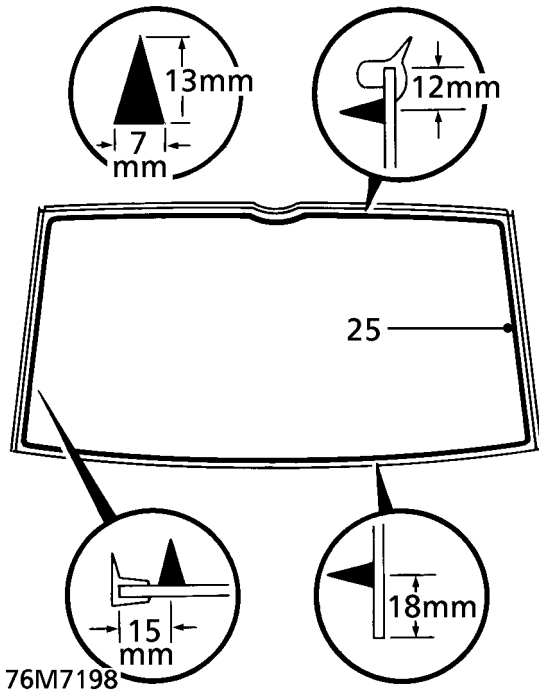

26. **Original glass:** Apply 3mm bead of sealer to channels of side finishers and fit to backlight.  
 27. Fit suction lifters to glass.  
 28. With assistance, fit glass and centralize to previously made tape markings. Set glass to correct depth.  
 29. Connect screen heater.  
 30. Remove reference and protective tapes.  
 31. Position lower finisher and secure to clips.  
 32. Fit interior trim to tailgate, **See this section.**



**CAUTION:** A curing time of 6 hours is recommended. During this time, leave the windows open and **DO NOT** slam the doors.

## REAR QUARTER LIGHT

Service repair no - 76.81.20



**NOTE:** The following equipment is required:

Masking tape.  
 Sharp knife.  
 Cutting wire and handles, or a reciprocating blade, powered cutting knife\*.  
 Suction Lifters.  
 Windscreen repair kit.  
 Sealer applicator gun.

\*A reciprocating blade cutting tool, such as 'FEIN Special Cutter' is recommended for this operation. A flat blade, with an effective length of at least 25mm and a 'U' shaped blade of at least 30mm is required.



**NOTE:** New rear quarter glass is supplied with exterior trim fitted.



**WARNING:** Wear protective gloves when handling glass, solvents and primers.

### Remove

1. Remove parcel tray support, **See this section.**
2. Remove both 'E' post trims, **See this section.**
3. Remove relevant 'B' post upper trim, **See this section.**
4. Remove relevant side interior lamp assembly, **See ELECTRICAL, Repair.**
5. Remove relevant grab handle, **See this section.**
6. Remove relevant exterior 'E' post finisher, **See this section.**

7. Remove 2 trim studs securing headlining to 'E' posts.

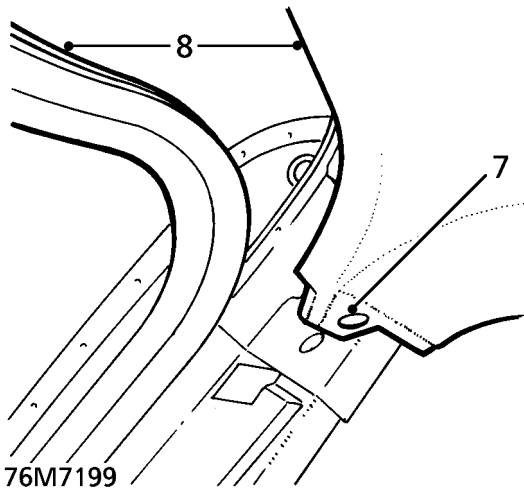

8. Release headlining from tailgate seal. Lower headlining as necessary during glass removal to provide access to sealant along top edge of glass.  
9. Disconnect aerial amplifier plugs.

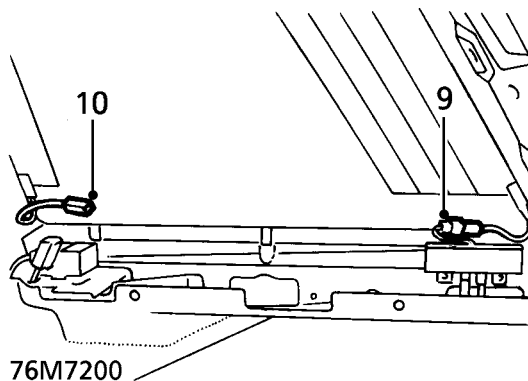

10. **R.H. glass only:** Disconnect alarm receiver plug.  
11. Protect surrounding area of body using masking tape.

### Removal Using Reciprocating Blade Tool

12. Lift flip seal to reveal trim fixings.

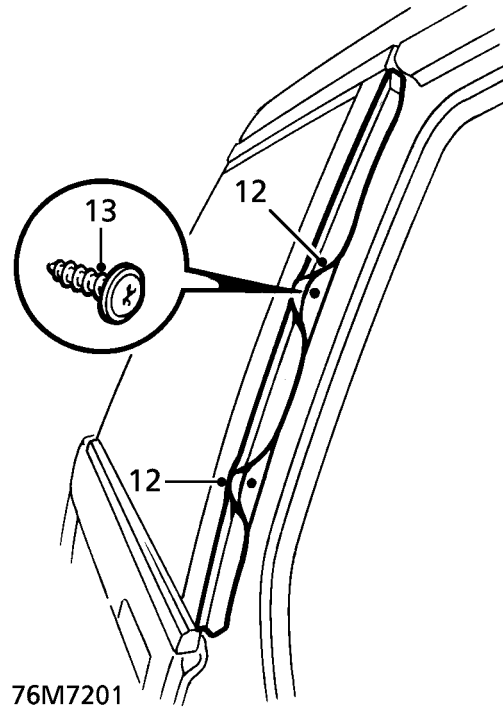

13. Remove 2 screws securing exterior trim to 'D' post.  
14. Cut through P.U. adhesive from inside of glass along lower and side edges.

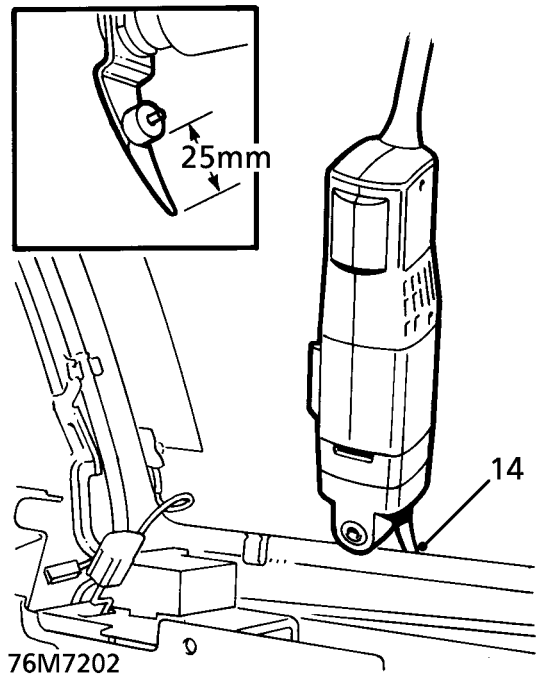



**CAUTION: Manoeuvre knife blade around 3 parcel tray support clips. Ensure aerial amplifier and alarm receiver plugs do not become damaged.**

15. Attach suction lifters to glass. With assistance, cut through sealant along top of edge glass.
16. Remove rear quarter glass.

**Removal Using Cutting Wire Handles**

17. Protect surrounding area of body using masking tape.
18. Lift flip seal to reveal trim fixings.
19. Remove 2 screws securing exterior trim to 'D' post.

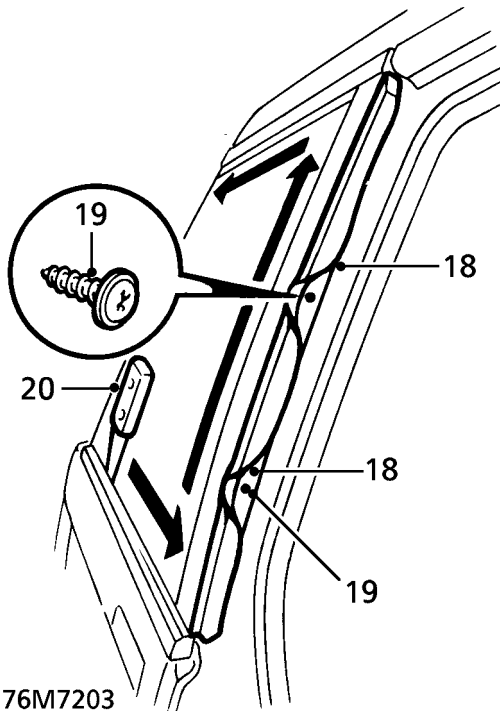

76M7203

20. Carefully cut through adhesive bead between glass and trim using a sharp knife.



**NOTE: A reciprocating blade cutting tool, such as 'FEIN Special Cutter' will ease the removal of the trim. Use a cranked blade with an effective length of not more than 22mm.**

21. Remove and discard quarter light trim.



**NOTE: Rear quarter lights are supplied with finisher fitted. Finisher is not available separately.**

22. Using a sharp knife, cut through P.U. sealer at forward edge of quarter glass.

23. Insert cutting wire through knife cut and fit handles, as shown, with approximately 200mm of wire between handles.

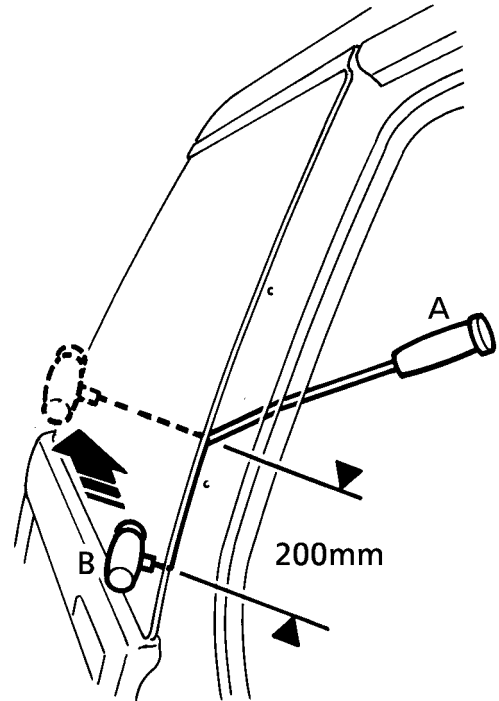

76M7205

24. With assistance, wedge tube of handles 'A' between glass and body, ahead of the cutting position, and carefully cut the sealer using a continuous pull on handle 'B' from the outside. Cut side and top edges first. Attach suction lifters as last sealant is cut.



**NOTE: When cutting along lower edge, manoeuvre wire between glass edge and parcel tray support clips to reduce strain on wire.**



**CAUTION: Ensure aerial amplifier and alarm receiver plugs do not become damaged.**

25. Remove rear quarter glass.

## Refit

26. Carefully cut old sealer from body flange to obtain a smooth surface, approximately 2mm thick.



**CAUTION: Do not cut down to painted surface.**

27. Position new quarter glass on felt covered surface.  
28. Apply cleaning solvent to sealing surface of glass and body flange.



**CAUTION: Do not touch cleaned or primed areas with fingers.**

29. Stick 4 self adhesive spacers on the inside edge of glass at corners.  
30. Shake primer tins for at least 30 seconds. Apply body primer to sealing surface of body flange using supplied applicator.  
31. Apply glass primer to sealing surface of glass.



**CAUTION: Use a separate applicator for each primer.**

32. Remove lid from sealer cartridge, remove crystals, pierce membrane and fit pre-cut nozzle. Fit cartridge to applicator gun.



**NOTE: The profile of the nozzle must be modified slightly to produce the required bead section.**

33. Apply a continuous bead of sealer to rear quarter glass as shown.

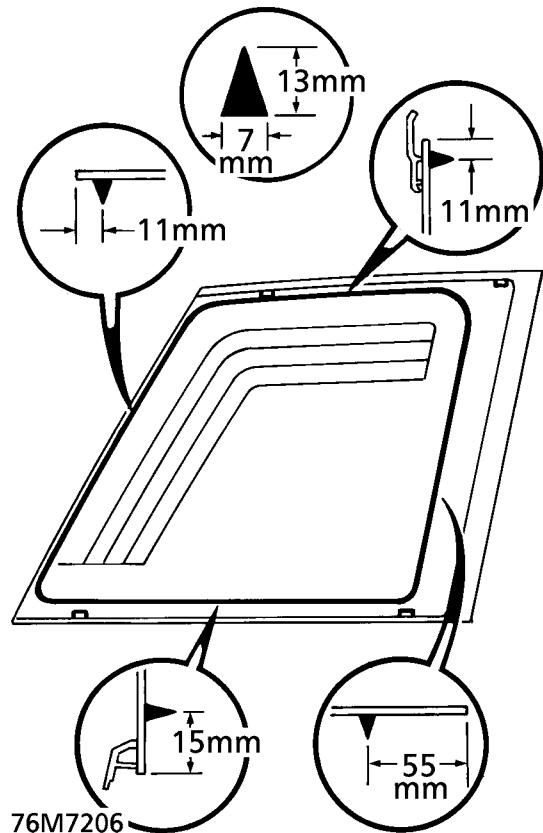

34. Fit suction lifters to glass.  
35. With assistance, fit glass and align to body. Seat glass to spacer rubbers.  
36. Remove protective tape.  
37. Secure exterior trim to 'D' post with screws.  
38. Connect aerial amplifier plug.  
39. **R.H. glass only:** Connect alarm receiver plug.  
40. Position headlining and engage beneath tailgate flip seal.  
41. Secure headlining to 'E' posts with trim studs.  
42. Fit exterior 'E' post finisher, **See this section.**  
43. Fit grab handle, **See this section.**  
44. Fit side interior lamp assembly, **See ELECTRICAL, Repair.**  
45. Fit 'B' post upper trim, **See this section.**  
46. Fit 'E' post trims, **See this section.**  
47. Fit parcel tray support, **See this section.**



**CAUTION: A curing time of 6 hours is recommended. During this time, leave the windows open and DO NOT slam the doors.**



## CORROSION PROTECTION

### Factory Treatments

The New Range Rover is treated with the following anti-corrosion materials in production:

- A PVC-based underbody sealer material which is sprayed onto the underfloor, wheel arches and undersill areas.
- An application of cavity wax which is sprayed into enclosed cavities, box sections and lower inner door panels.
- A final coating of underbody wax to cover the complete underfloor including components but excluding brake discs.
- A coat of protective lacquer or wax applied to the engine bay area.

In addition to the above measures, all steel parts are zinc-coated both sides, and front wings, door and tailgate skins are manufactured from aluminium.

The information given on the following pages is intended as a guide and shows the areas to be treated with cavity wax, as well as the access holes used during manufacture. **See GENERAL INFORMATION DATA, Sealing and corrosion protection section.**

### Underbody Wax

A coat of underbody wax is applied to the entire underbody inboard of the sill vertical flanges, and covers all moving and flexible components EXCEPT for wheels and tyres, brakes and exhaust. The wax is applied over paints and underbody sealers.

The underbody wax must be reinstated following all repairs affecting floor panels.



**CAUTION: Old underbody wax must be completely removed from a zone extending at least 200mm (7.9in.) beyond the area where new underbody sealer is to be applied.**

### Underbody Sealer

Underfloor areas and outer sill panels are treated with a Plastisol PVC underbody sealer. This material is not suitable for re-treatment.

When repairing areas of underbody sealer, strip the factory-applied material back to a suitable break point, ensuring that a clean metal surface is exposed and that the edge of the existing material adheres soundly to the panel.

Blanking plugs and grommets in the floor pan (except those used for wax injection) MUST be fitted before underbody sealer application. Heat-fusible plugs which have been disturbed should either be refitted with the aid of a hot air blower or replaced with rubber grommets.



**NOTE: Application of new underbody sealer must be carried out between primer and surfacer paint operations. Areas where seam sealer is used should be re-treated as necessary before application of underbody sealer.**



**CAUTION: Ensure that suspension units, wheels, tyres, power unit, driveshafts, exhaust and brakes (including all mounting points) are shielded prior to application of fresh underbody sealer.**

### Engine Bay Wax

Reinstate protective engine bay wax disturbed during repairs using the approved material.

**Stone Chip Resistant Paint/Primer**

Re-treat all areas protected with factory-applied anti-chip primer with suitable approved material in repair.

**Inspections during Maintenance Servicing**

It is a requirement of the Land Rover Corrosion Warranty that the vehicle body is checked for corrosion by an authorised Land Rover dealer at least once a year, to ensure that the factory-applied protection remains effective.

Service Job Sheets include the following operations to check bodywork for corrosion:

- With the vehicle on a lift, carry out visual check of underbody sealer for damage.
- With the vehicle lowered, inspect exterior paintwork for damage and body panels for corrosion.



**NOTE: Wash the vehicle and ensure that it is free from deposits prior to inspection. It is part of the owner's responsibility to ensure that the vehicle is kept free of accumulations of mud which could accelerate the onset of corrosion. The Dealer MUST wash the vehicle prior to inspection of bodywork if the customer has offered it in a dirty condition, and pay special attention to areas where access is difficult.**



**NOTE: The checks described above are intended to be visual only. It is not intended that the operator should remove trim panels, finishers, rubbing strips or sound deadening materials when checking the vehicle for corrosion and paint damage.**

With the vehicle on a lift, and using an inspection or spot lamp, visually check for the following:

- Corrosion damage and damaged paintwork, condition of underbody sealer on front and rear lower panels, sills and wheel arches.
- Damage to underbody sealer on main floor and chassis members. Corrosion in areas adjacent to suspension mountings and fuel tank fixings.



**NOTE: The presence of small blisters in PVC underbody sealer is acceptable, providing they do not expose bare metal.**

Special attention must be paid to signs of damage caused to panels or corrosion material by incorrect jack positioning.

It is essential to follow the correct jacking and lifting procedures. **See GENERAL INFORMATION DATA, Information section.**

With the vehicle lowered, visually check for evidence of damage and corrosion on all painted areas, in particular the following:

- Front edge of bonnet.
- Visible flanges in engine compartment and boot.
- Lower body and door panels.

Where bodywork damage or evidence of corrosion is found during inspection, rectify this as soon as is practicable, both to minimise the extent of the damage and to ensure the long term effectiveness of the factory-applied corrosion protection treatment. Where the cost of rectification work is the owner's responsibility, the Dealer must advise the owner and endorse the relevant documentation accordingly.

Where corrosion has become evident and is emanating from beneath a removable component (e.g. trim panel, window glass, seat etc.), remove the component as required to permit effective rectification.



### Underbody Protection Repairs

When body repairs are carried out, always ensure that full sealing and corrosion protection treatments are restored. This applies both to the damaged area, and also to areas where protection has been indirectly impaired as a result of accident damage or repair operations.

Prior to straightening out or panel beating, remove all corrosion protection material in the damaged area. This applies in particular to panels coated with wax, PVC underbody sealer, sound deadening pads etc.



**WARNING: DO NOT use oxy-acetylene gas equipment to remove corrosion prevention materials. Large amounts of fumes and gases are liberated by these materials when they burn.**

Equipment for the removal of tough anti-corrosion sealers offers varying degrees of speed and effectiveness. The compressed air-operated scraper (NOT an air chisel) offers a relatively quiet mechanical method of removal using an extremely rapid reciprocating action. During use, direct the operating end of the tool along the work surface.

The most common method is by the use of a hot air blower with integral scraper.



**CAUTION: High temperatures can be generated with this equipment which may cause fumes. Always exercise care in its use.**

Another tool, and one of the most efficient methods, is the rapid-cutting 'hot knife'. This tool uses a wide blade and is quick and versatile, able to be used easily in profiled sections where access is otherwise awkward.

Use the following procedure when repairing underbody coatings:

1. Remove existing underbody coatings.

2. After panel repair, clean the affected area with a solvent wipe, and treat bare metal with an etch phosphate material.
3. Re-prime the affected area. **DO NOT under any circumstances apply underbody sealer directly to bare metal surfaces.**
4. Replace all heat-fusible plugs which have been disturbed. Use rubber grommets of equivalent size if plugs are not available, but ensure that they are embedded in sealer.
5. Mask off all mounting faces from which mechanical components, hoses and pipe clips, have been removed. Underbody sealer must be applied **before** such components are refitted.
6. Brush sealer into all exposed seams.
7. Spray the affected area with an approved service underbody sealer.
8. Remove masking from component mating faces, and touch-in where necessary. Allow adequate drying time before applying underbody wax.

### Underbody Wax

After refitting mechanical components, including hoses, pipes and small fixtures, mask off the brake discs and apply a coat of approved underbody wax.



**NOTE: Where repairs include the application of finish paint coats in the areas requiring underbody wax, paint operations must be carried out BEFORE wax application.**

### Underbonnet Wax

Where repairs have involved replacement of engine bay panels, treat the entire engine compartment including all components, clips and small fixtures with an approved underbonnet lacquer or wax.

### Proprietary Anti-Corrosion Treatments

The application of proprietary anti-corrosion treatments in addition to the factory-applied treatment could invalidate the Corrosion Warranty and should be discouraged. This does not apply to approved, compatible, preservative waxes which may be applied on top of existing coatings.



### Fitting Approved Accessories

When fitting accessories it is important that the vehicle's corrosion protection is not affected, either by breaking the protective coating or by introducing a moisture trap.

DO NOT screw self-tapping screws directly into the body panel but fit plastic inserts first. Protect the edges of holes drilled into panels, chassis members and other body parts with a suitable zinc rich or acid etch primer, followed by a protective wax coating brushed onto the surrounding area.

DO NOT affix unpainted metal surfaces of any accessory directly to the vehicle bodywork unless they are suitably protected. Where metal faces are bolted together always interpose a suitable interface material such as weldable zinc rich primer, extruded strip or zinc tape.

### Cavity Wax Injection

Box sections treated with cavity wax are shown in this section. Repairs affecting these areas must include re-treatment with an approved cavity wax, using the access points illustrated. In addition, all interior surfaces which have been disturbed during repairs must be wax injected whether they have been treated in production or not. This includes all box members, cavities, door interiors etc. It is permissible to drill extra holes for access where necessary, provided these are not positioned in load-bearing members. Ensure that such holes are treated with a suitable zinc rich primer, brushed with wax and then sealed with a rubber grommet.

Prior to wax injection, ensure that the cavity to be treated is free from any contamination or foreign matter. Where necessary, clear out any debris using a compressed air supply.

Carry out wax injection after final paint operations. During application, ensure that the wax covers all flange and seam areas and that it is applied to all repaired areas of both new and existing panels.



**NOTE: Apply cavity wax AFTER the final paint process and BEFORE refitting of any trim components.**

It should also be noted that new panel assemblies and body shells are supplied without wax injection treatment which must be carried out after repairs.

Effective cavity wax protection is vital. Always observe the following points:

- Complete all finish paint operations before wax application.
- Clean body panel areas and blow-clean cavities if necessary, before treatment.
- Maintain a temperature of 18° C during application and drying.
- Check the spray pattern of injection equipment.
- Mask off all areas not to be wax coated and which could be contaminated by wax overspray.
- Remove body fixings, such as seat belt retractors, if contamination is at all likely.
- Move door glasses to fully closed position before treating door interiors.
- Treat body areas normally covered by trim before refitting items.
- Check that body and door drain holes are clear after the protective wax has dried.
- Keep all equipment clean, especially wax injection nozzles.



Application Equipment and Techniques

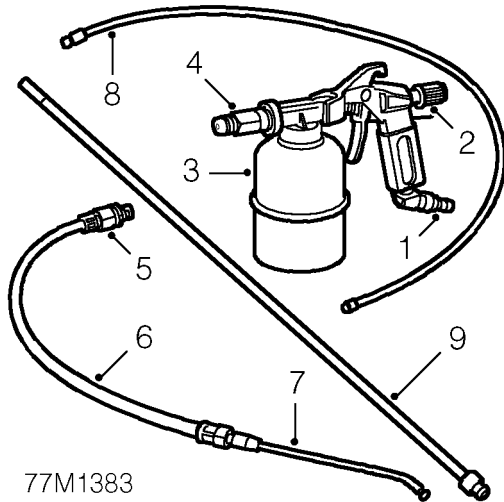

77M1383

1. Air inlet
2. Flow control (spray pattern adjustment)
3. Pressure cup (1 litre [1.7pt.] capacity). Maximum pressure 140PSI (9.7 bar, 9.8kg/cm<sup>2</sup>).
4. Gun connector
5. Lance nipple connection
6. Flexible lance
7. Rigid directional hook wand (forward cone spray pattern)
8. Flexible nylon 1100mm (43.3in.) lance with 360° spray pattern
9. Rigid 1100mm (43.3in.) lance with 360° spray pattern

When re-treating wax-injected areas which have been disturbed during repairs, it is necessary to use a compressed air spray gun with integral pressure cup and a selection of interchangeable lances.

The following points must be observed during use, according to the attachments fitted:

- Use the rigid or flexible lance attachments with 360° spray dispersal when treating enclosed areas, to ensure maximum coverage.
- Where openings are restricted, use the hook nozzle to provide a more directional spray (e.g. inside narrow or short box sections).
- Spray exposed underbody surfaces directly from the gun less lance attachment and without disconnecting the fluid coupling.

**1100 mm (43.3in.) Rigid Lance:**The nozzle on the rigid lance produces a 360° circular spray pattern combined with a forward-directed spray. Although wax is distributed to all box section surfaces in a single stroke, effective and complete coverage is best achieved in long, straight structures and box section cavities by spraying on both outbound and return strokes of the lance.

The rigid lance also provides the positional accuracy required in shaped sections, by allowing visual assessment.



**CAUTION: Do not force the lance into access holes when using this attachment.**

**1100 mm (43.3in.) Flexible Nylon Lance:**This lance is similar in pattern to the rigid version, but provides the additional penetration needed for curved sections or in places where access is difficult. Its main limitation is a lack of positional accuracy inside box sections.

Carry out spraying on the outward stroke of the lance. Withdraw the lance slowly to ensure sufficient coverage. **DO NOT withdraw the lance too quickly.**

Keep the nylon tube of the lance away from the edges of the access hole to eliminate abrasion and extend the life of the tube. Take care to ensure that spraying ceases just before the nozzle emerges from the access hole. To assist this process, apply RED paint to the final 30mm (1.2in.) of the nozzle.

**Hook Nozzle on Flexible Lance:** The rigid hook produces a highly atomised, forward-directed, fully conical spray pattern having long range and good dispersion characteristics. This combination has good directional capabilities for the treatment of short, narrow sections and may also be used for direct spraying of inner wheelarches etc.

Position the flat area at the end of the lance at 180° to the nozzle spray direction. This will help to guide the spray more accurately when it is concealed in a box section or access hole.

For general spraying move the nozzle in an arc from side to side, to ensure full coverage.



**NOTE: Keep all wax injection/application equipment clean. Use white spirit for this purpose immediately after wax injection operations.**

#### Precautions during Body Repairs and Handling

Take care when handling the vehicle in the workshop. PVC underbody sealers, seam sealers, underbody wax and body panels may be damaged if the vehicle is carelessly lifted.

Always follow the correct lifting, jacking and towing procedures as shown in **GENERAL INFORMATION DATA, Information section**, paying particular attention to the following points:

- Locate trolley jack pads properly before lifting and lower the jack fully before withdrawal.
- Use only the approved hoisting points when overhead hoisting is required.
- Locate the lifting heads of wheel-free lifts correctly, with rubber or similar material placed between lifting head and underbody.

#### Steam Cleaning and Dewaxing

Due to the high temperatures generated by steam cleaning equipment, there is a risk that certain trim items could be damaged and some adhesives and corrosion prevention materials softened or liquified.

Adjust the equipment so that the nozzle temperature does not exceed 90° C (194° F). Take care not to allow the steam jet to dwell on one area, and keep the nozzle at least 300mm (11.8in.) from panel surfaces.

Do NOT remove wax or lacquer from underbody or underbonnet areas during repairs. Should it be necessary to steam clean these areas, apply a new coating of wax or underbody protection as soon as possible.



---

**CAVITY WAX**

---

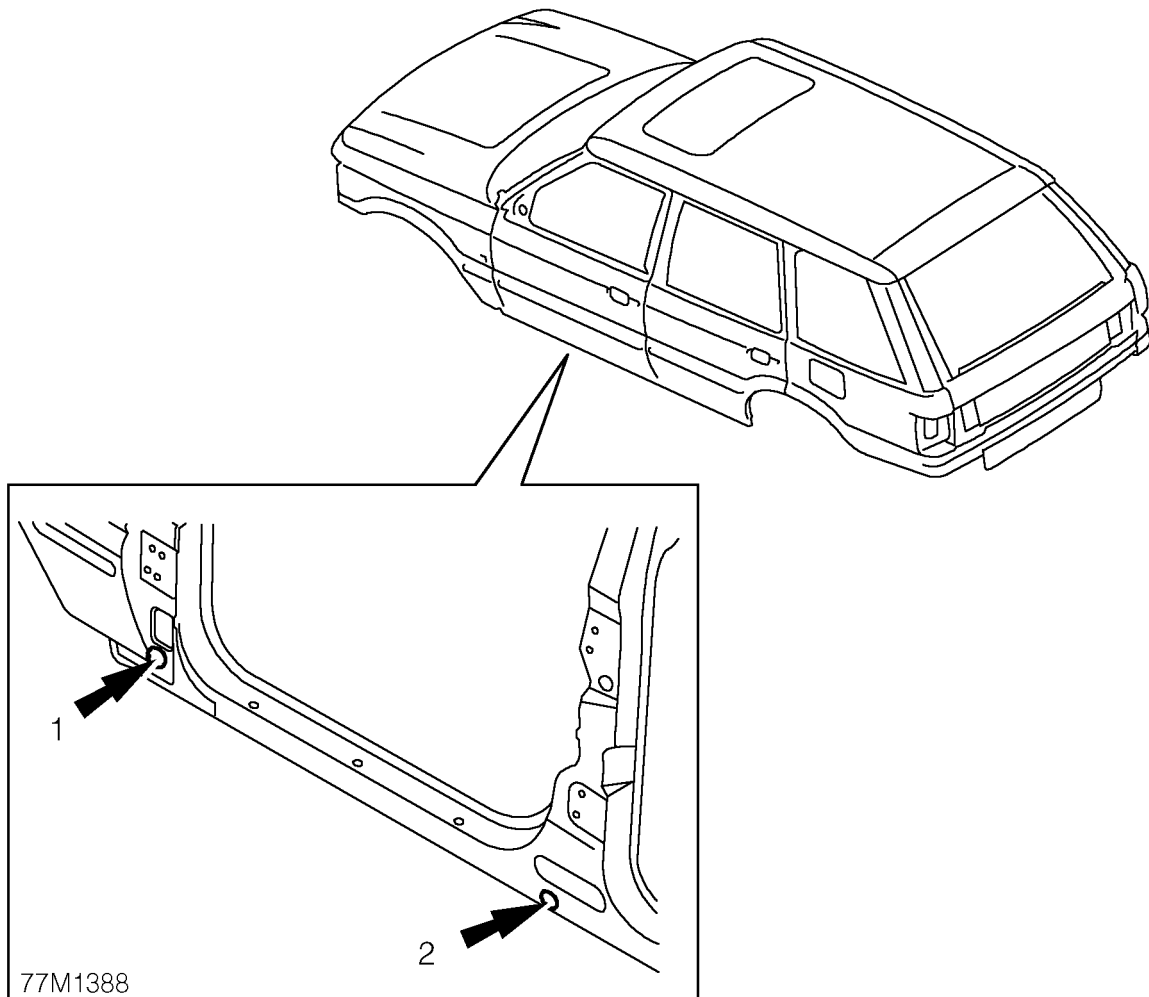

1. Injection hole at lower 'A' post.
2. Injection hole at lower 'B' post.

All areas symmetrically opposite to those shown are also treated.

See **GENERAL INFORMATION DATA, Information section.**

## SEALANTS AND ADHESIVES

### Structural Adhesive

Metal-to-metal adhesive is applied to critical joint areas during factory assembly. The material used is a high-temperature, heat cured, nitrile phenolic which serves both to bond two metal surfaces and also to seal the joint against ingress of dust, water, petrol and fumes. This material is not suited for service use, and should be substituted in repair using a suitable medium strength adhesive.

When separating a joint treated with metal-to-metal adhesive, to avoid distortion it is recommended that the joint be gently heated until the bonds weakens sufficiently to permit panel separation.



**NOTE: Spot welding through metal-to-metal adhesive is feasible, but take special care to adjust the transformer setting to ensure a reliable weld. DO NOT carry out MIG welding on a joint area which has been treated with metal-to-metal adhesive until all traces of adhesive have been removed.**

### Seam Sealers

A heat cured, PVC Plastisol sealer is applied to joint areas during factory assembly. This material is not suitable for service use.

Carry out seam sealing after the application of primer and before the surfacer and final paint coats. Ensure that surfaces are first cleaned of all grease and oil. Apply the sealer material to the joint as a bead, either by hand or using an applicator gun. Brush sealer well into the joint and wipe smooth using a cloth soaked with solvent such as Shell SBP3. This will ensure an acceptable cosmetic finish.

Apply sealer to ALL accessible joints following repair work. Be aware that damage to a vehicle can often result in deflection to those areas of the body which are remote from the impact. The sealers in these areas can therefore be disturbed by subsequent straightening and repair operations. Check joints in the vicinity of the area undergoing repair for evidence of cracked sealer, clean them out as required and re-treat them with fresh sealer using the following procedure:

- Clean the affected joint or seam and re-treat any exposed metal areas with a suitable etch phosphate primer.
- Treat affected area with an acid-etch primer.
- Apply appropriate seam sealer as necessary.
- Apply appropriate colour coat (and underbody sealer as applicable).

Where joints are inaccessible following the reassembly or fitment of components, ensure that a paste-type sealer is applied to such joints. Certain seams also become inaccessible after the completion of panel repairs. In such instances the paint process should be carried out and sealers applied before final assembly.

Provided access is adequate, apply the sealer to both sides of the repair joint. Where access is limited to one side only (e.g. box sections), inject the affected box member with cavity wax.



**CAUTION: ALWAYS deploy an extractor unit to remove toxic fumes when using oxy-acetylene equipment to remove panels treated with wax and sealers.**



### Sealing Water Leaks

Sealing charts in this section show those areas of the bodyshell most likely to be affected by accident damage and water leaks, and which could therefore require re-treatment in repair. They do not show those joint areas which only apply to factory assembly operations and which are unlikely to be disturbed in service (e.g. centre tunnel), or where the damage would be so severe that the entire bodyshell would normally be written off.

When water leakage occurs, always adopt a logical approach to the problem using a combination of skill, experience and intuition. Do not attempt to reach a conclusion based only on visual evidence, such as assuming that a leak emanates from the windscreen because the footwell is wet. It will often be found that the source of the leak is elsewhere. The correct procedure will increase the chance of locating a leak, however obscure it may seem.

### Tools and Equipment

The following tools and equipment are recommended for detection and rectification of water leaks:

1. Garden sprayer (hand-operated).
2. Wet/dry vacuum cleaner.
3. Dry absorbent cloths.
4. Battery torch.
5. Small mirror.
6. Weatherstrip locating tool.
7. Trim panel remover.
8. Small wooden or plastic wedges.
9. Dry compressed air supply.
10. Hot air blower.
11. Sealer applicators.
12. Ultrasonic leak detector.

During leak detection, the vehicle should be considered in three basic sections:

- The front interior space,
- The rear passenger space (where applicable), and
- The rear loadspace or boot.

### Testing

From the information supplied by the customer it should be possible for the bodyshop operator to locate the starting point from which the leak may be detected. After the area of the leak has been identified, find the actual point of entry into the vehicle. A simple and effective means initially is an ordinary garden spray with provision for pressure and jet adjustment. This will allow water to be directed in a jet or turned into a fine spray. Use a mirror and a battery-powered torch (NOT a mains voltage inspection lamp) to see into dark corners.

The sequence of testing is particularly important. Start at the lowest point and work slowly upwards, to avoid testing in one area while masking the leak in another. For example, if testing started at the level of the windscreen, any water cascading into the plenum chamber could leak through a bulkhead grommet and into the footwells. Even at this point it could still be wrongly assumed that the windscreen seal was at fault.

Another important part of identifying a water leak is by visual examination of door aperture seals, grommets and weatherstrips for damage, deterioration or misalignment, together with the fit of the door itself against the seals.

**Sealing**

When the point of the leak has been detected, proceed to rectify it using the following procedure:

1. Renew all door aperture seals and weatherstrips which have suffered damage, misalignment or deterioration.
2. Check all body seals to ensure that they are correctly located on their mounting flanges/faces using a locating tool if necessary.
3. Dry out body seams to be treated using compressed air and/or a hot air blower as necessary.
4. Apply sealant on the outside of the joint wherever possible to ensure the exclusion of water.
5. When rectifying leaks between a screen glass and its weatherstrip (or in the case of direct glazing, between the glass and bodywork), avoid removing the glass if possible. Apply the approved material either at the glass to weatherstrip or glass to body.



SEALING CHARTS

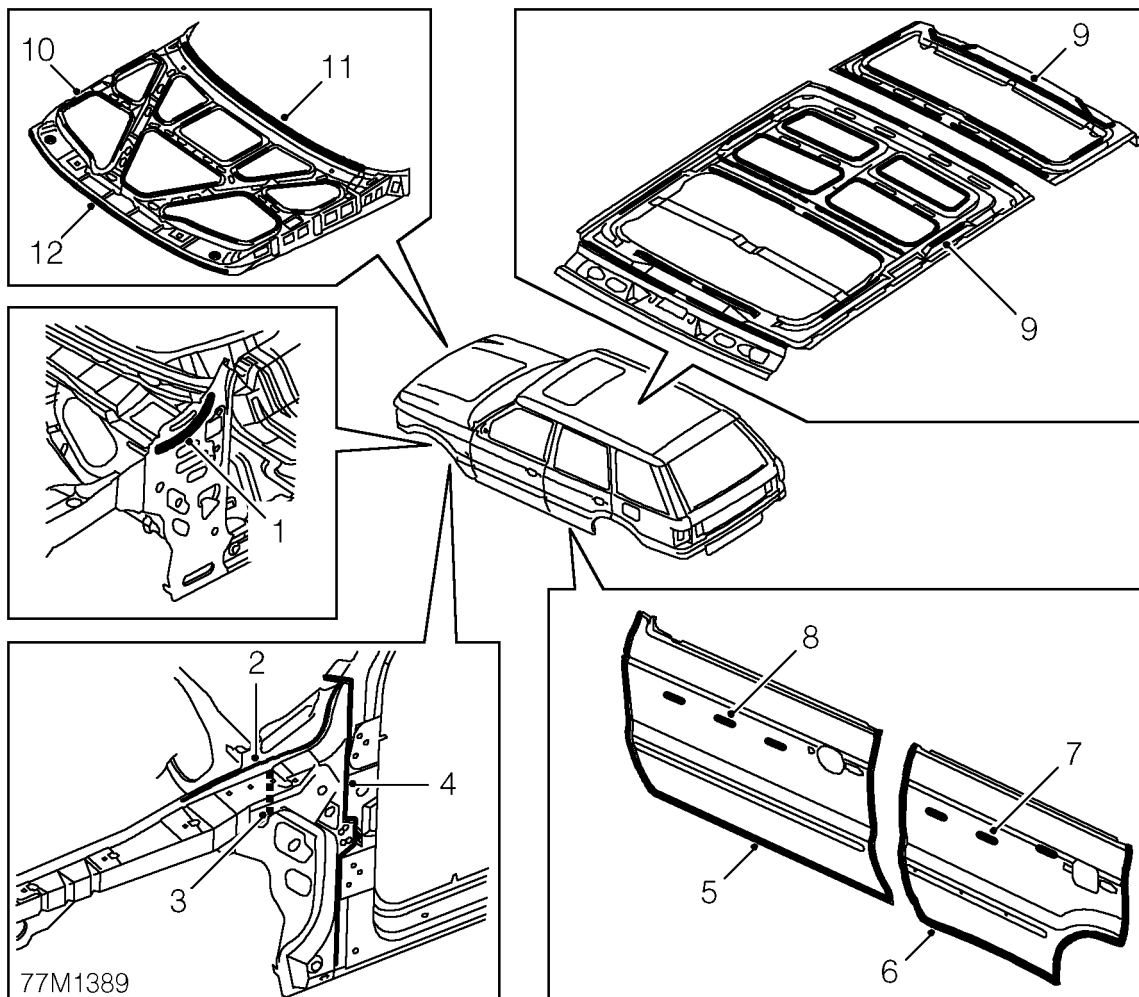

- |                                     |  |
|-------------------------------------|--|
| 1. Structural adhesive              | 7. Semi-structural adhesive/anti-flutter material  |
| 2. Structural adhesive              | 8. Semi-structural adhesive/anti-flutter material  |
| 3. Structural adhesive              | 9. Semi-structural adhesive/anti-flutter material  |
| 4. Structural adhesive              | 10. Semi-structural adhesive/anti-flutter material |
| 5. Structural adhesive, seam sealer | 11. Structural adhesive                            |
| 6. Structural adhesive, seam sealer | 12. Structural adhesive                            |

All areas symmetrically opposite to those shown are also treated.

see **GENERAL INFORMATION DATA, Information section.**



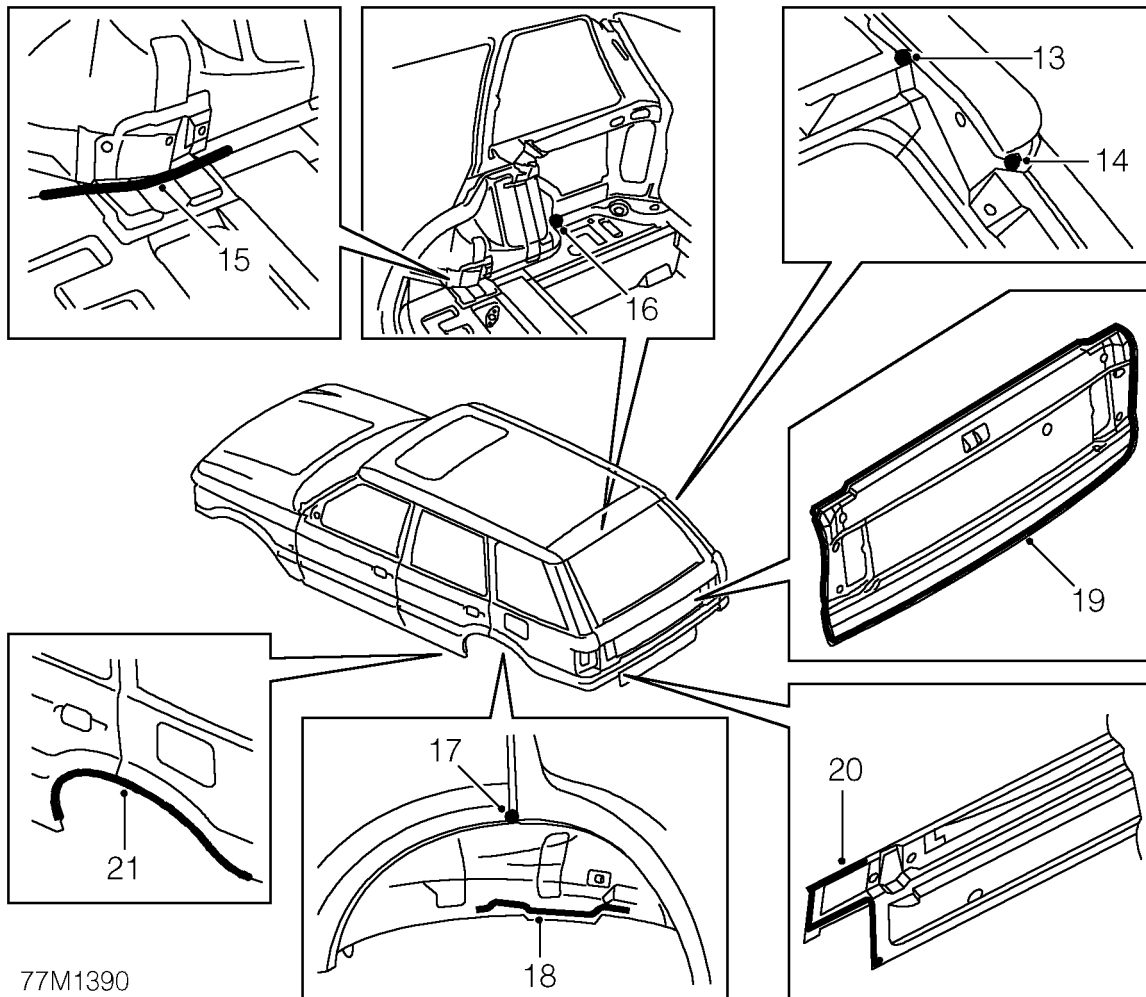

77M1390

- |                              |                         |
|------------------------------|-------------------------|
| 13. Putty                    | 18. Structural adhesive |
| 14. Putty                    | 19. Structural adhesive |
| 15. Structural adhesive      | 20. Structural adhesive |
| 16. Putty, seam sealer heavy | 21. Structural adhesive |
| 17. Putty, seam sealer heavy |                         |

All areas symmetrically opposite to those shown are also treated.

See **GENERAL INFORMATION DATA, Information section.**

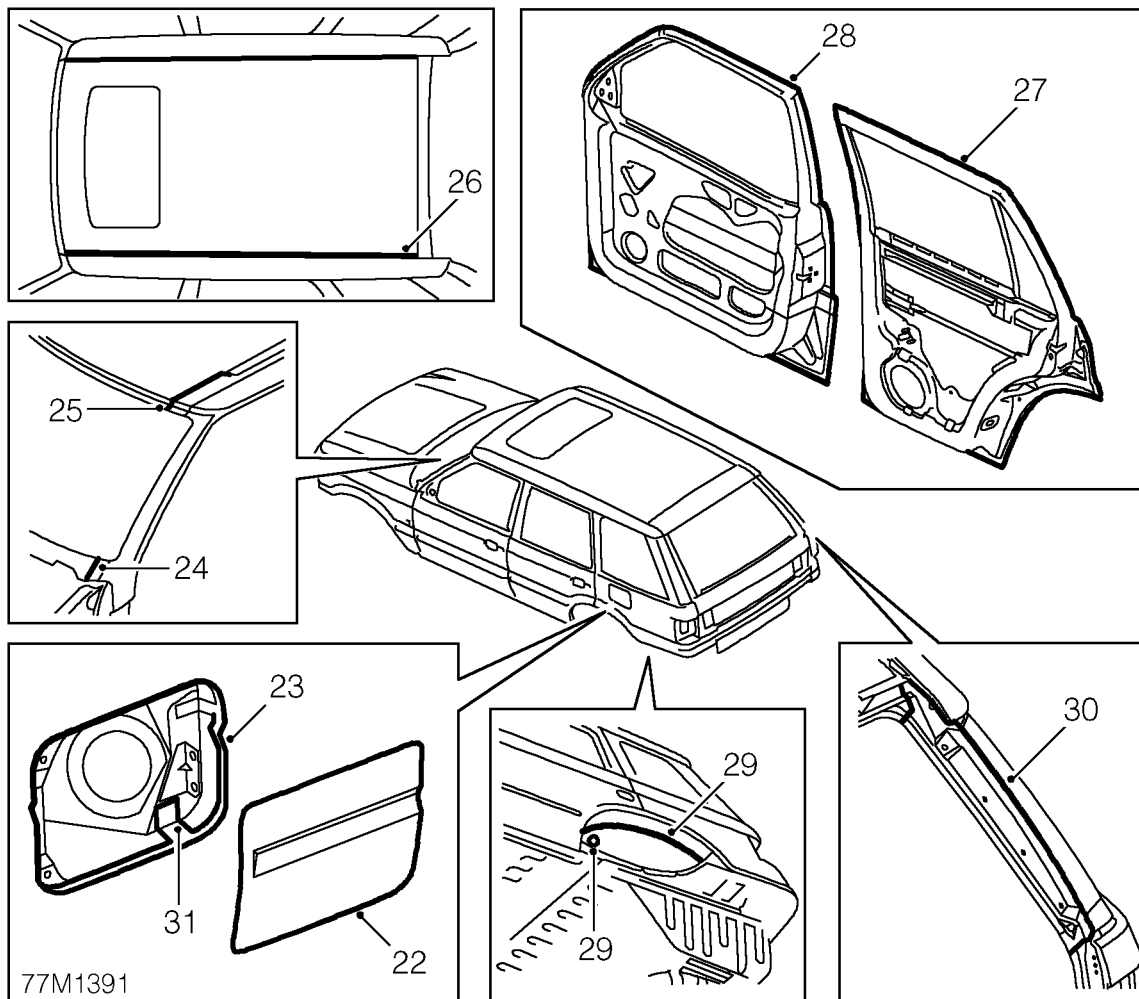

- |  |                       |
|--|-----------------------|
| 22. Structural adhesive                            | 27. Seam sealer       |
| 23. Semi-structural adhesive/anti-flutter material | 28. Seam sealer       |
| 24. Seam sealer light                              | 29. Seam sealer heavy |
| 25. Seam sealer light, structural adhesive         | 30. Seam sealer light |
| 26. Seam sealer light                              | 31. Seam sealer light |

All areas symmetrically opposite to those shown are also treated.

See **GENERAL INFORMATION DATA, Information section.**

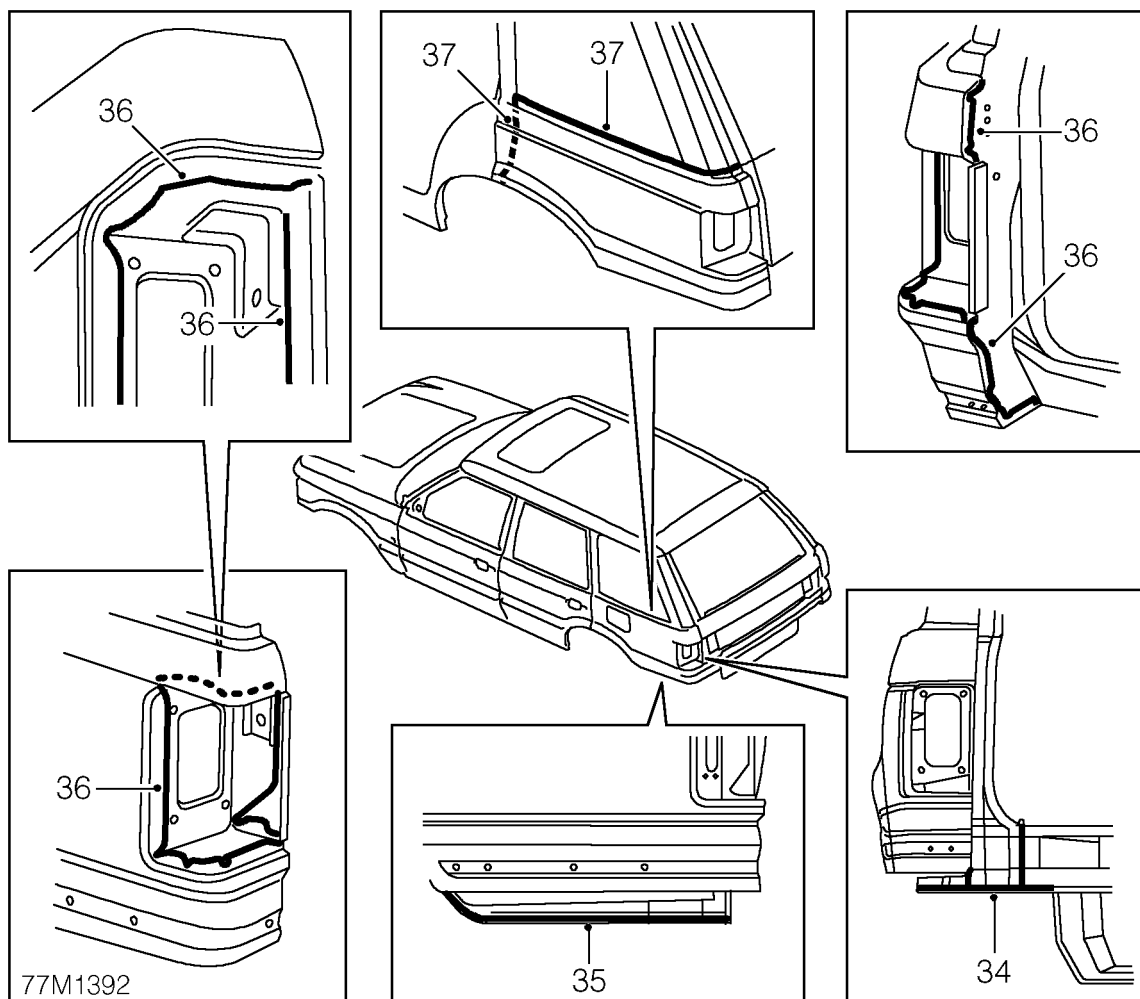

- 34. Seam sealer light
- 35. Seam sealer light
- 36. Seam sealer light
- 37. Seam sealer light

All areas symmetrically opposite to those shown are also treated.

See **GENERAL INFORMATION DATA, Information section.**

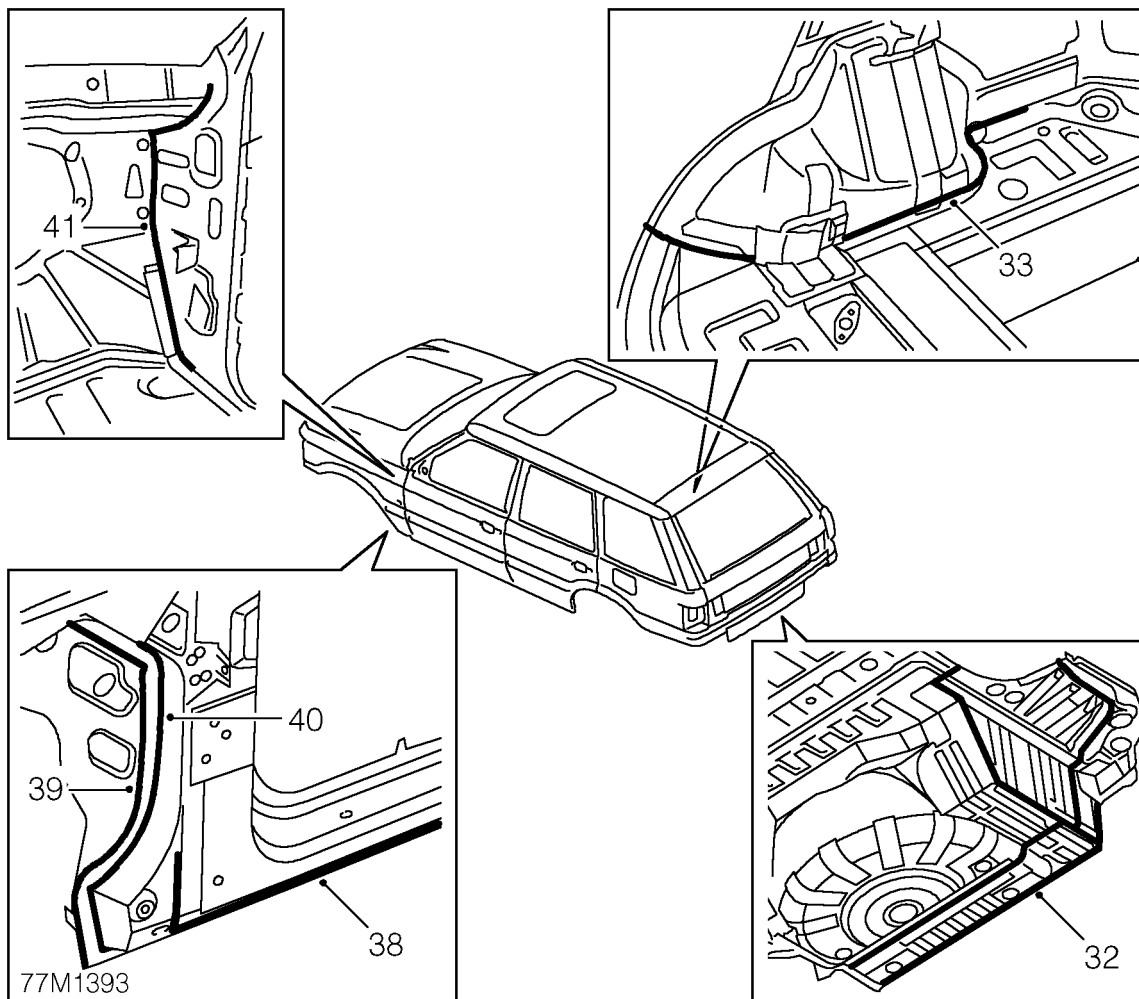

- 32. Brushable sealer
- 33. Seam sealer light
- 38. Seam sealer light
- 39. Seam sealer light
- 40. Seam sealer light
- 41. Seam sealer light

All areas symmetrically opposite to those shown are also treated.

See **GENERAL INFORMATION DATA, Information section.**



## PAINT

### Replacement Panels

Service panels are supplied with a cathodic primer coating as part of the panel protection, and in compliance with the vehicle's Corrosion Warranty where applicable. **DO NOT remove this primer before paint refinishing. In the event of localised surface damage or imperfections, ensure that the minimum of primer is removed during rectification work for effective repair.**

Rectify damage by panel beating or straightening. To remove corrosion or paint runs on outer surfaces, abrade primer coat in the affected area as necessary using the following procedure:

1. Clean the panel using a solvent wipe.
2. Treat exposed areas of metal with an etch phosphate process.
3. Re-treat the affected area using either a separate acid-etch primer and two-pack surfacer, or an integrated etch primer/filler.

### Bolted Panels

Before fitting bolt-on panels, ensure that all mating and adjacent surfaces on the vehicle and replacement panel are free from damage and distortion. Rectify if necessary as described in this section, and apply preformed strip sealer where specified.

### Welded Panels

1. Remove primer from the immediate vicinity of new and existing panel flanges, cleaning to bright metal finish.
2. On joints to be spot welded, apply weld-through zinc rich primer to joint faces of both flanges. Make spot welds while primer is still wet or according to the manufacturer's instructions.
3. Dress accessible weld seams.
4. Clean panel using solvent wipe.
5. Treat bare metal with an etch phosphate process.
6. Re-treat repaired areas.



**NOTE: It is not satisfactory to use weld-through, zinc rich primers in conjunction with arc or MIG welding.**

### Sectioned Panels

When replacing part or sectioned panels, the basic procedure is the same as for welded panels described above, with the following variations:

1. Remove primer from both new and existing joint faces, cleaning to a bright metal finish.
2. Where an overlap joint with the existing panel is to be spot welded, apply weld-through, zinc rich primer to both joint faces and spot weld while the primer is still wet or according to the manufacturer's instructions.
3. MIG weld butt joints where applicable.
4. Clean the panel with a solvent wipe.
5. Treat bare metal areas using an etch phosphate process.
6. Re-prime affected areas as necessary as for rectifying transit damage. **See this section.**
7. Treat the inner faces of lap or butt joints with a suitable cavity wax. **See Sealing and corrosion protection.**

### Clinch Panels (eg Doorskins etc.)

1. Abrade primer on new and existing panel joint faces, and clean using a solvent wipe.
2. Apply metal-to-metal adhesive where applicable.
3. Where joints are to be spot welded, apply suitable weld-through, zinc rich primer to weld areas.
4. Where joints are to be MIG, arc or gas welded, apply zinc rich primer in adjacent areas **but leave the welded area untreated.**
5. To retain the panel whilst clinching the flanges, tack spot weld or plug weld as appropriate.
6. Clean the panel with a solvent wipe.
7. Treat bare metal areas with a suitable etch phosphate process.
8. Re-prime affected areas as necessary as for rectifying transit damage. **See this section.**



**NOTE: Replacement doors, bonnets and tailgates must be treated with a suitable seam sealer on clinched seams, following the primer coat.**

### Paint Refinishing

1. Seal all accessible exterior and interior seams with an approved seam sealer. Certain joints such as sill lower flange seams must be left unsealed.
2. Apply a suitable anti-chip primer where specified.
3. Apply a two-pack paint refinishing system.
4. Repair any damage to underbody sealers either at this stage or before paint operations.

### Paint Repairs

Before carrying out paintwork repairs, the vehicle must be thoroughly cleaned using either a steam cleaner or high-pressure washer.

Wash locally repaired areas using a mild water-mixable detergent and wipe them clean with solvent, immediately prior to paint application.

Abrade damaged paintwork where bare metal has been exposed until the metal is clean and extends beyond the area of immediate damage. Treat the bare metal with an etch phosphate to remove all traces of rust and provide a key for new paint coats. Re-treat the affected area using either a separate acid-etch primer and two-pack surfacer or an integrated etch primer/filler, and follow with a two-pack paint system. Those surfaces not receiving paint must be treated with a cavity wax following paint operations.

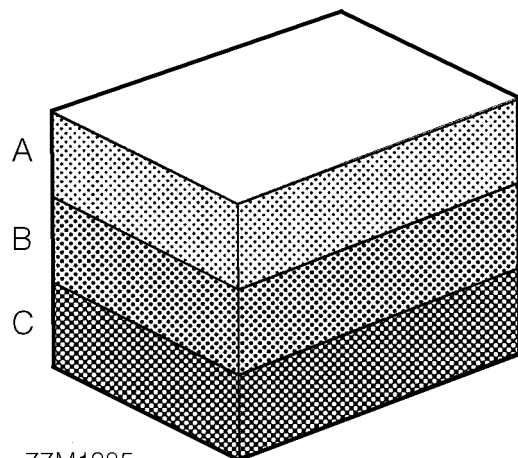

77M1385

- A. Two-pack top coat
- B. Two-pack primer filler and etch primer
- C. Etch phosphate



**SERVICE CONDITION OF PANELS**

**Bodyshell Assembly**

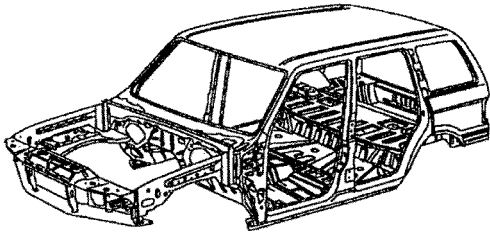

77M1453

Bodyshells, which are also supplied with sunroof aperture (not shown), are serviced less front wings, bonnet, door assemblies and upper/lower tailgates.

**Headlamp and Grille Panel**

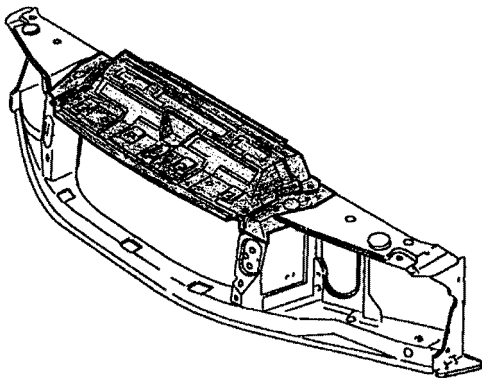

77M1454

Headlamp/grille panels are serviced as a complete assembly including a bolt-on bonnet lock platform.

**Front Wing**

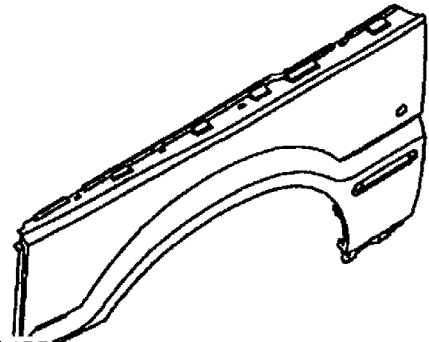

77M1455

Front wings are serviced as separate bolt-on aluminium panels.

**Bonnet**

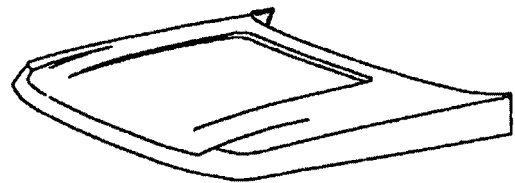

77M1456

Bonnets are serviced less hinges which are available separately.

**Valance and Wheelarch**

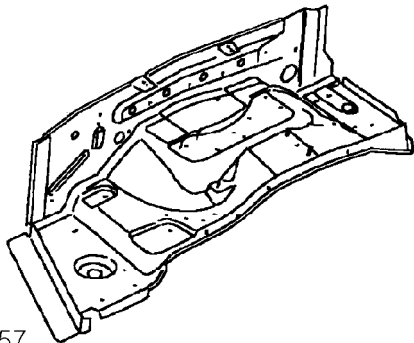

77M1457

Valance and wheelarch panels are serviced as a separate part and are fitted to the bulkhead.

**Front Sidemember**

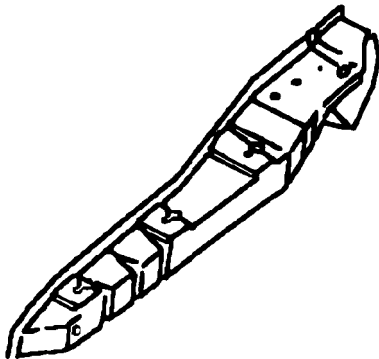

77M1458

Front sidemembers are fitted to the 'A' post and valance/wheelarch.

**'A' Post Lower**

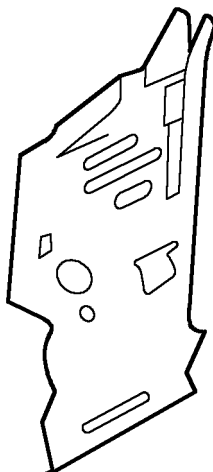

77M1459

The 'A' post lower is fitted to the bulkhead, inner sill and 'A' post reinforcement.

**'A' Post Panels**

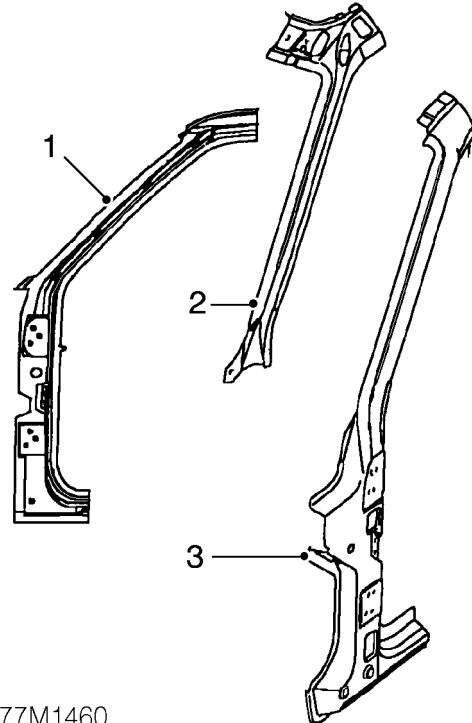

77M1460

'A' posts are serviced as separate 'A' post repair panel (1), upper 'A' post (2) and 'A' post reinforcement (3).

**'B' Post Panels**

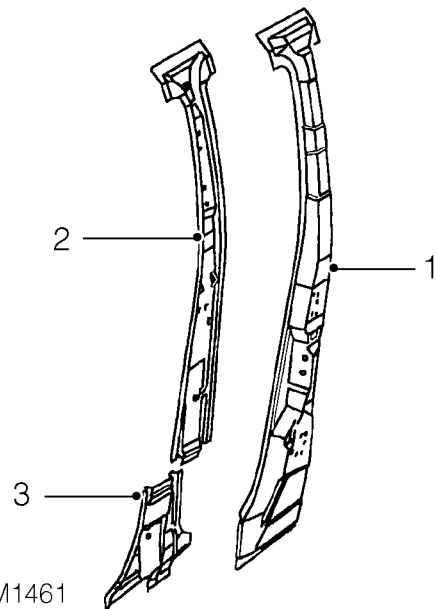

77M1461

'B' posts are serviced as separate 'BC' post reinforcement (1) and inner 'BC' post panels (2, 3).





**Door Assemblies and Outer Door Panels**

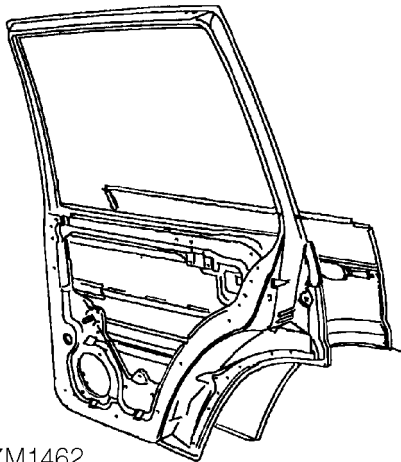
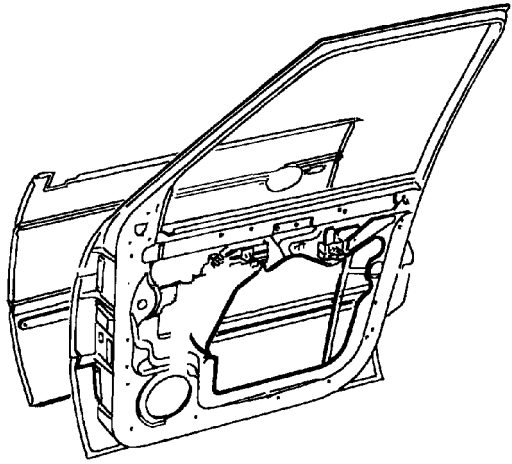

77M1462

Door assemblies comprise an aluminium outer panel fitted to a steel frame.

**'BC' Post Repair Panel**

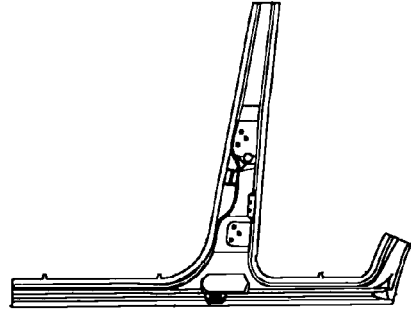

77M1463

'BC' posts are serviced as a complete panel including the sill.

**Roof Assembly**

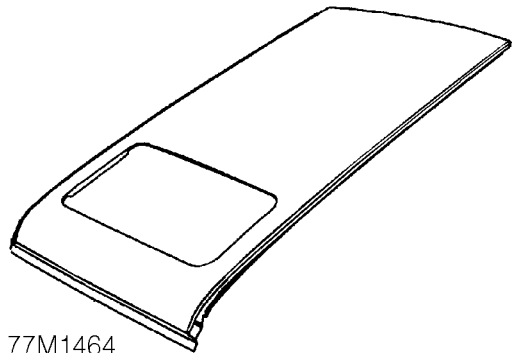

77M1464

Roof assemblies are serviced complete with inner frames.

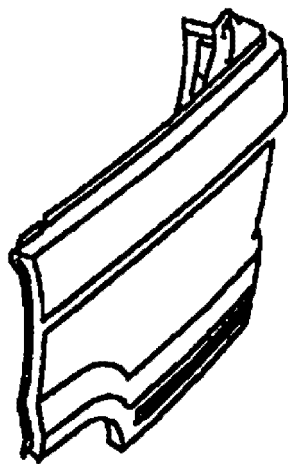
**Outer Rear Quarter Panel**

77M1465

Outer rear quarters are serviced as a separate panel.

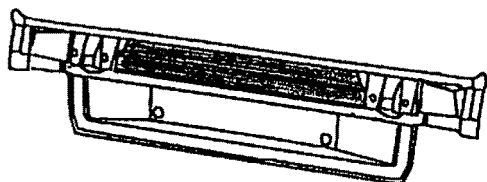
**Lower Panel**

77M1466

Lower panels are serviced as an assembly including the tailgate lock reinforcement.

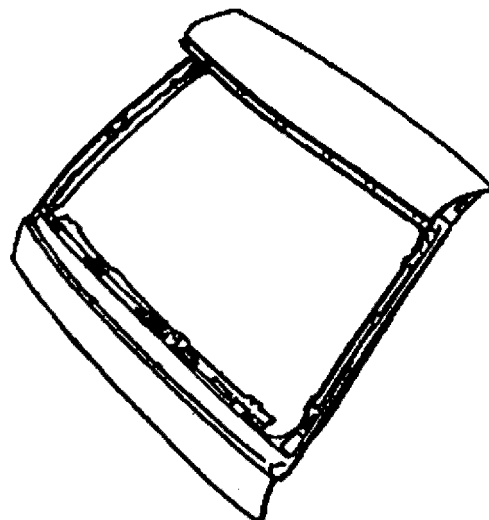
**Upper Tailgate Assembly**

77M1467

Upper tailgates are serviced less hinges, which are available separately.

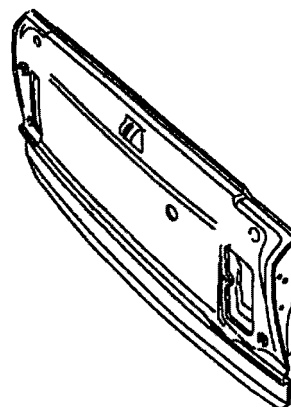
**Lower Tailgate Assembly**

77M1468

Lower tailgate assemblies comprise an aluminium outer panel fitted to a steel frame and are serviced less hinges, which are available separately. Lower tailgate outer panels are also serviced as separate items.



**Inner Rear Quarter Panel**

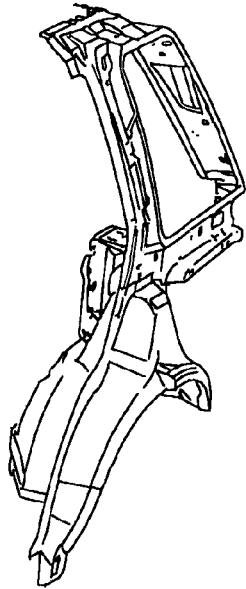

77M1469

Inner rear quarters are serviced as an assembly with associated reinforcements and brackets.

**Rear Crossmember Panel**

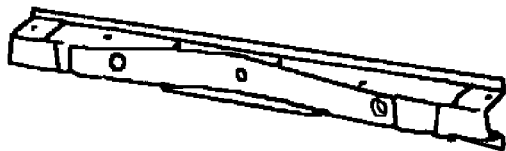

77M1470

The rear crossmember is serviced as a separate panel.

**Load Floor Side**

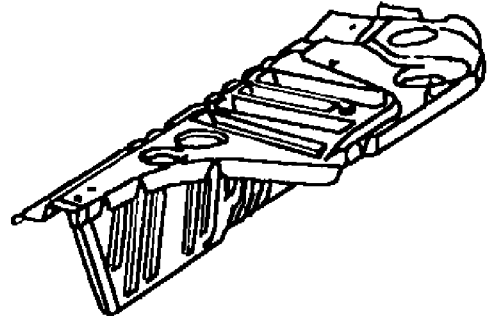

77M1471

Load floor sides are serviced as a separate panel.

**Rear Crossmember Extension**

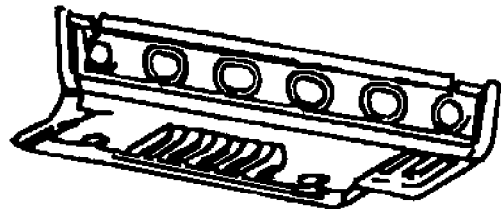

77M1472

The rear crossmember extension is serviced separately.

### Rear Quarter Repair Panel

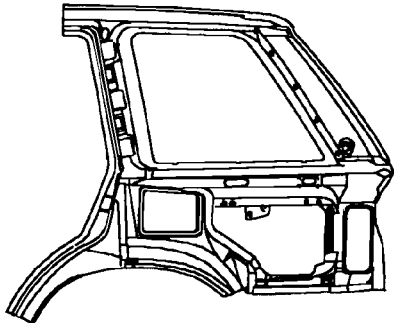

77M1473

The rear quarter which is fitted between the outer panel and inner quarter is serviced as a separate repair panel.

### Spare Wheel Closing Panel



77M1474

The spare wheel closing panel is serviced separately and fits at the upper front of the spare wheel well.



**GENERAL WELDING PRECAUTIONS**

For ease of reference the diagrams on the following pages show only the type of weld used in repair where this varies from that used in production.

When carrying out welding operations the following criteria must be observed:

- Where resistance spot welds have been used in production, these must be reproduced with new spot welds in replacement where possible. All such reproduction spot welds must be spaced 30mm (1.2in.) apart.
- When spot welding, it is recommended that test coupons of the same metal gauges and materials are produced to carry out peel tests to ensure that welding equipment being used can produce a satisfactory joint. Plug welds must be used if a satisfactory spot weld cannot be produced.
- The electrode arms on hand-held spot welding guns must not exceed 300mm in length.
- Single-sided spot welding is not acceptable.
- Brazing and gas welding are not acceptable EXCEPT where they have been specified in production.
- Where 3 metal thicknesses or more are to be welded together it is imperative to use MIG plug welds to ensure joint strength.
- MIG plug welds must be used in repair joints where there is no access for a resistance spot welder. To replace each production spot weld a hole must be drilled and/or punched, and a MIG weld then made in its place. The number of plug welds must match exactly the number of spot welds which have been removed.
- Where holes are left in an existing panel after removal of the spot welds, a single MIG plug weld will be made in each hole as appropriate.

- The replacement welds in the welding diagrams are denoted by the following symbols:



77M1386

- A. Single thickness plug welds
- B. Multiple thickness plug welds
- C. MIG seam weld

**Seat Belt Anchorages**

Seat belt anchorages are safety critical. When making repairs in these areas it is essential to follow design specifications. Note that High Strength Low Alloy (HSLA) steel may be used for seat belt anchorages.

Where possible, the original production assembly should be used, complete with its seat belt anchorages, or the cut line should be so arranged that the original seatbelt anchorage is not disturbed.

All welds within 250mm (9.9in.) of seat belt anchorages must be carefully checked for weld quality, including spacing of spot welds.



**WARNING: Body parts incorporating seat belt anchorages MUST be renewed completely if damaged beyond repair, as the welds in these areas are safety critical and cannot be disturbed.**

## PANEL REPLACEMENT PROCEDURE

### General

This information is designed to explain the basic panel removal and replacement method. This standard method may vary slightly from one vehicle to another. The main criterion in removal and replacement of body panels is that Land Rover's original standard is maintained as far as possible.

### Remove Panel

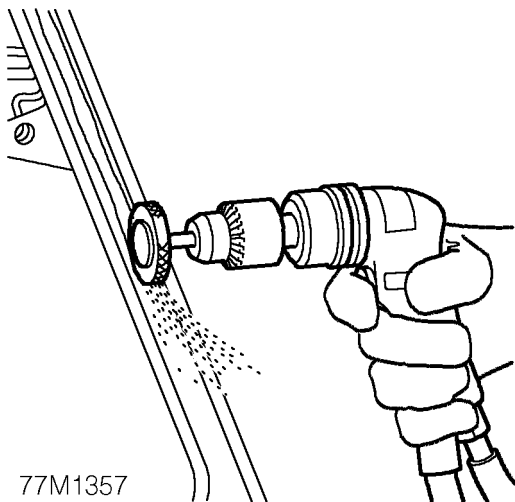

1. Expose resistance spot welds. For those spot welds which are not obviously visible, use a rotary impregnated wire brush fitted to an air drill, or alternatively a hand held wire brush.

 **NOTE:** In wheelarch areas it may be necessary to soften underbody coating using a hot air gun, prior to exposing spot welds.

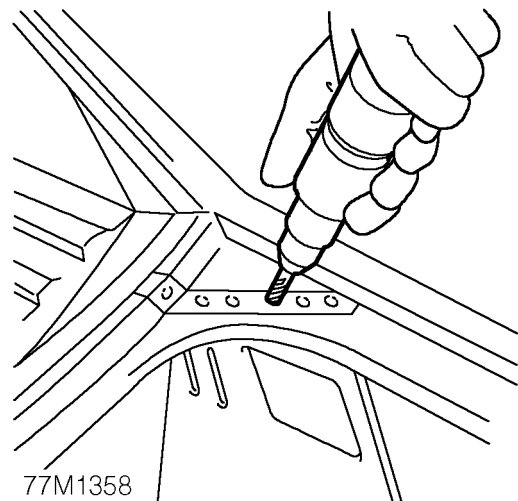

2. Cut out welds using a cobalt drill.

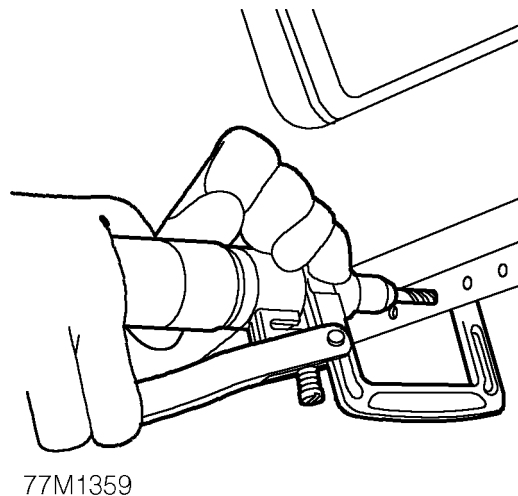

3. Alternatively use a clamp-type spot weld remover.

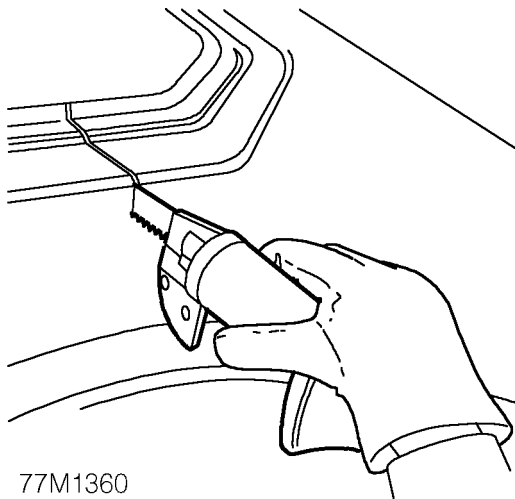

77M1360

- Cut away the bulk of the panel as necessary using an air saw.



**NOTE: On certain panel joints MIG welds and braze should be removed using a sander where possible, before cutting out the panel bulk.**

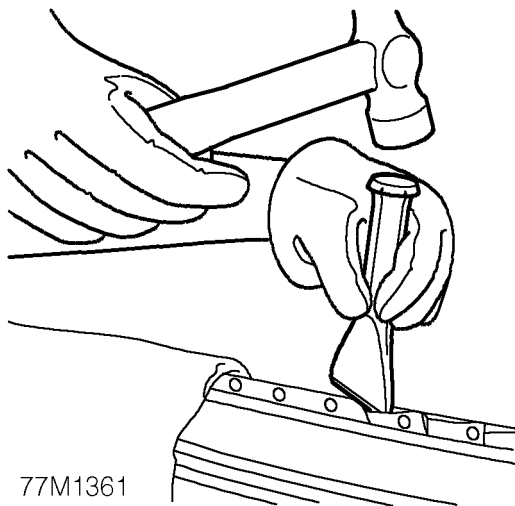

77M1361

- Separate spot welded joints and remove panel remnants using hammer, bolster chisel and pincers.

**Prepare Old Surfaces**

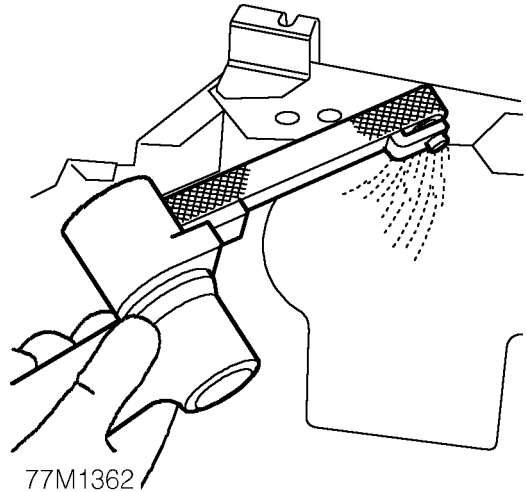

77M1362

- Clean all panel joint edges to a bright smooth finish, using a belt-type sander.



**NOTE: Prior to sanding, remove remaining sealant using a hot air gun to minimise the risk of toxic fumes caused by generated heat. CARE MUST BE TAKEN TO AVOID EXCESSIVE HEAT BUILD UP WHICH MAY BE CAUSED BY THIS EQUIPMENT.**

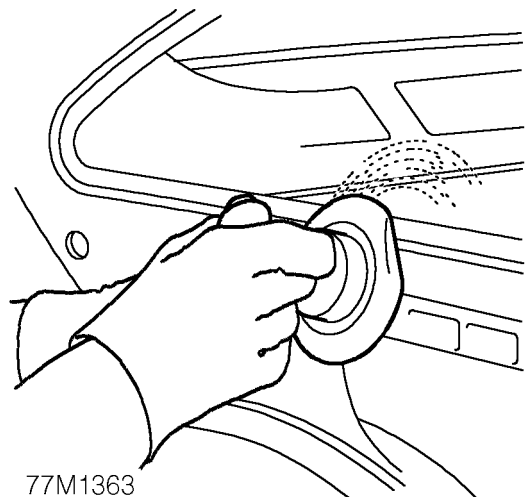

77M1363

- As an alternative a disc sander may be used. Straighten existing joint edges using shaping block and hammer.

## Prepare New Surfaces

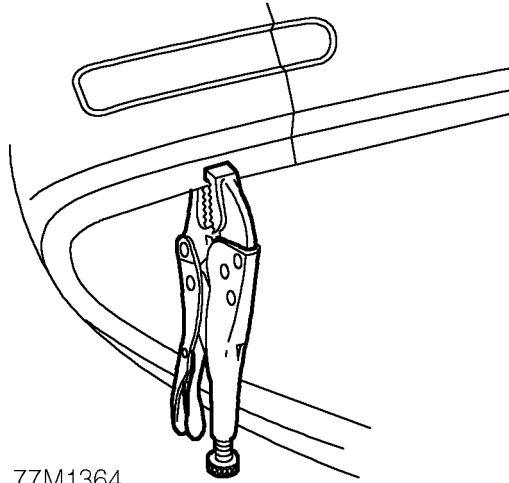

77M1364

8. Mark out bulk of new panel and trim to size, leaving approximately 50mm (1.9in.) overlap with existing panel. Offer up new panel/section, align with associated panels (e.g. new rear quarter aligned with door and tailgate). Clamp into position.

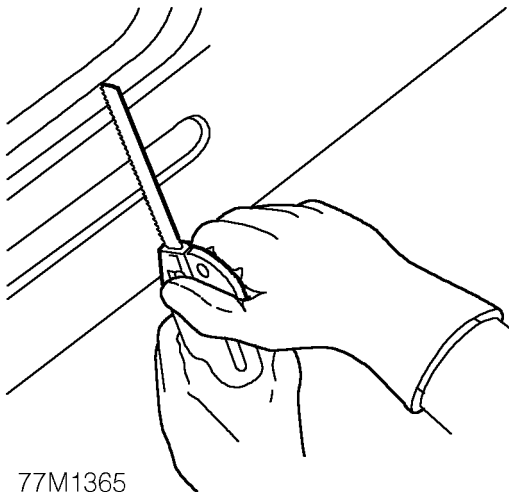

77M1365

9. Cut new and existing panels as necessary to form butt, joggle or brace joint as required. Remove all clamps and metal remnants.

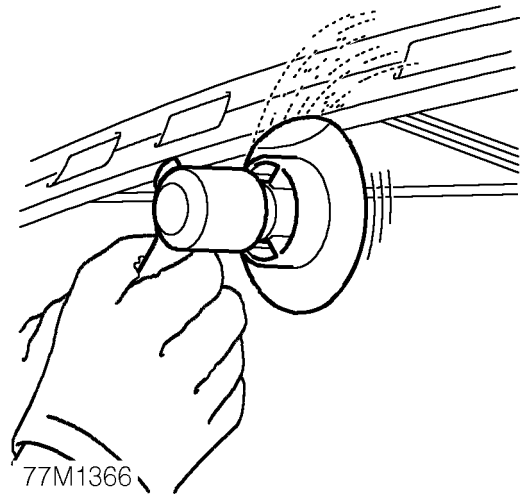

77M1366

10. Prepare new panel joint edges for welding by sanding to a bright finish. This must include inner as well as outer faces.

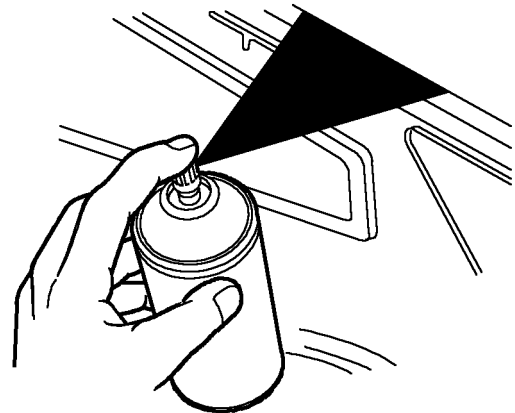

77M1367

11. Apply suitable weld-through primer to panel joint surfaces to be welded, using brush or aerosol can.



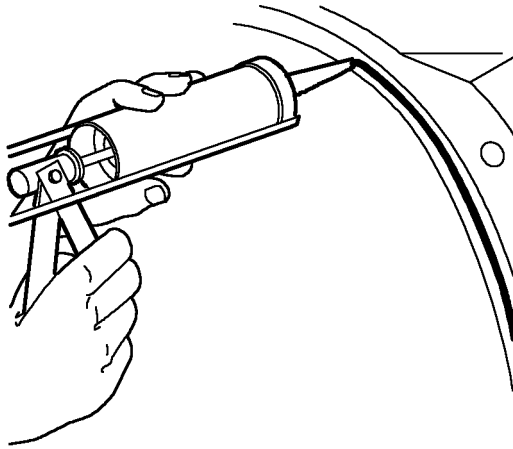

77M1368

12. Apply adhesive sealant to panel joint surfaces. See **GENERAL SPECIFICATION DATA, Information section.**

**Offer Up and Align**

Offer up new panel and align with associated panels. Clamp into position using welding clamps or Mole grips. Where a joggle or brace joint is being adopted, make a set in the original panel joint edge or insert a brace behind the joint.



**NOTE:** In cases where access for welding clamps is difficult, it may be necessary to use tack welds.

**Welding**

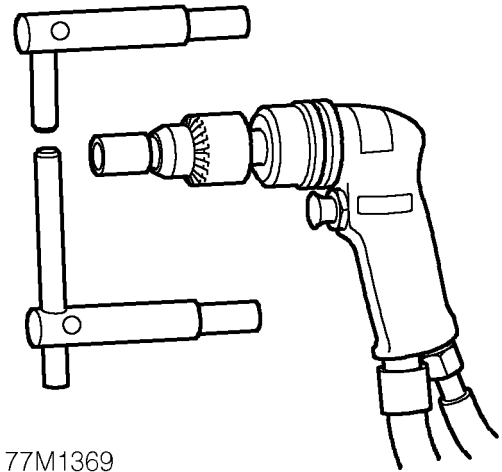

77M1369

13. Select arms for resistance spot welding and shape electrode tips using a tip trimmer.



**NOTE:** To maintain efficiency, the tips will require regular cleaning with emery cloth.



**CAUTION:** Use electrode arms not exceeding 300mm (11.8in.) in length.

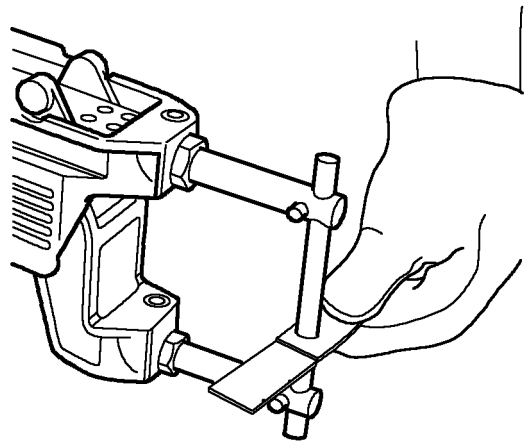

77M1370

14. Fit resistance spot welding arms and test equipment for satisfactory operation, using test coupons. Where monitoring equipment is not available, verify weld strength by checking that metal around the weld puddle pulls apart under tension during pulling.

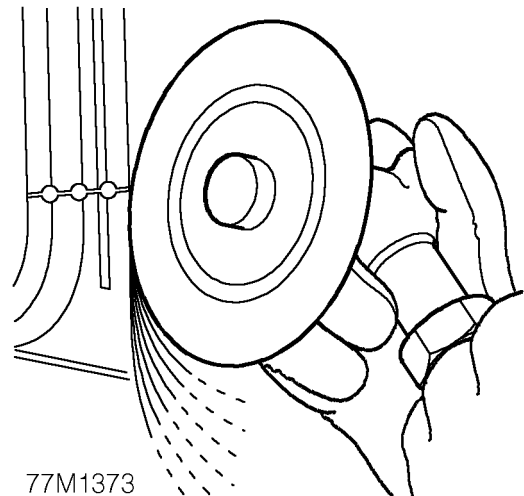
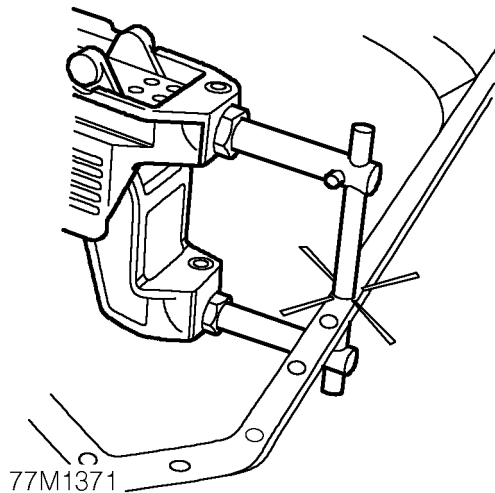

15. Use a resistance spot welder where access permits. Try to ensure weld quality by using a weld monitor where possible.

17. Dress MIG tack welds using a sander with 36 grit disc, or a belt-type sander where access is limited.

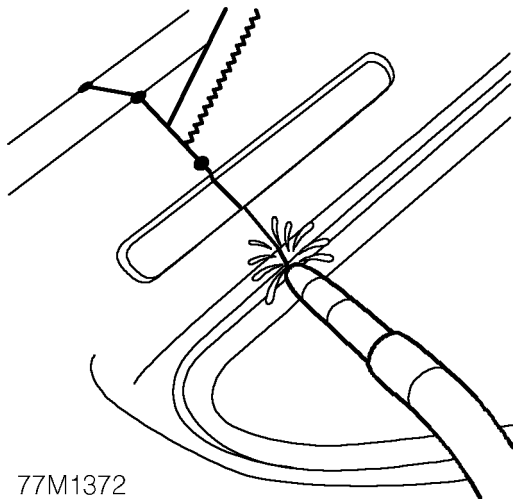

16. MIG tack weld butt joints and re-check alignment and panel contours where necessary. Ensure that a gap is maintained to minimise welding distortion, by inserting a hacksaw blade as an approximate guide.

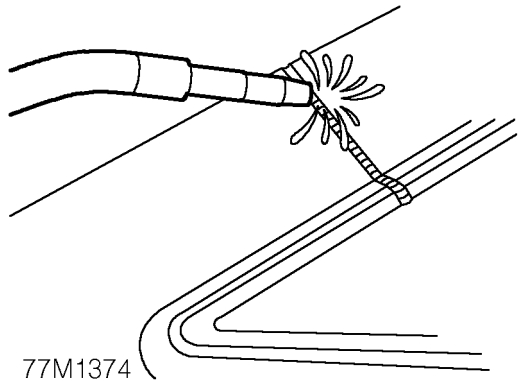

77M1374

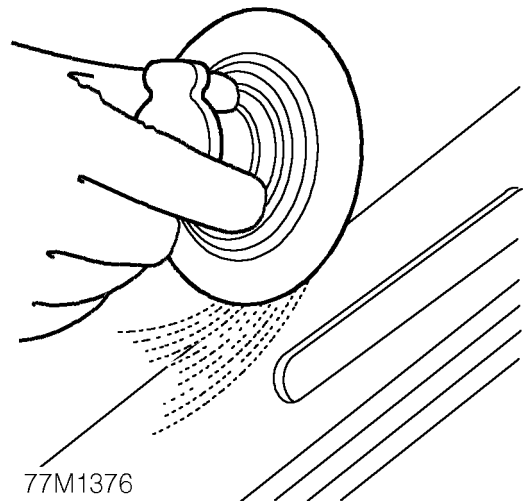

77M1376

18. MIG seam weld butt joints.

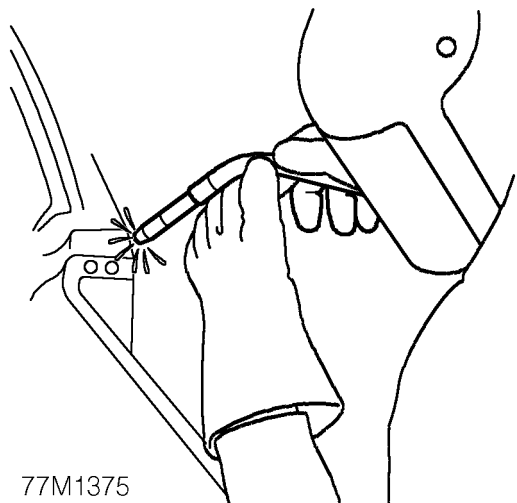

77M1375

19. Always use MIG plug welds where excessive metal thickness or lack of access make resistance spot welding impractical. Make plug welds either by using holes left by the spot weld cutter, or through holes punched or drilled for the purpose.

20. Dress all welds using a sander with 36 grit disc, or a belt-type sander and/or impregnated wire brush.



**NOTE: Brazing operations, if required, must be carried out at this point.**

**Body Trim**

The following panel repair operations itemise body trim components which must be removed for access during each repair. **See Repairs section.**

Because of the unpredictable nature of accident damage, the items listed make no allowance for any difficulties which may be found in removal and only apply to an undamaged vehicle. No allowance is made for any difficulties which may be found during panel removal. Damaged body trim items must be renewed as necessary following body repairs.



**VALANCE AND WHEELARCH**

**Remove**

1. Disconnect battery earth lead.
2. Raise front of vehicle.



**WARNING: Support on safety stands.**

3. Disconnect all ECUs.
4. Disconnect airbags and sensor system.
5. Remove airbag modules. **See SUPPLEMENTARY RESTRAINT SYSTEM, Repair.**
6. Disconnect alternator.
7. Remove front bumper valance. **See CHASSIS AND BODY, Repair.**
8. Remove extension spoiler front bumper. **See CHASSIS AND BODY, Repair.**
9. Remove front grille. **See CHASSIS AND BODY, Repair.**
10. Remove headlamp. **See Workshop Manual - ELECTRICAL.**
11. Remove bonnet. **See CHASSIS AND BODY, Repair.**
12. Remove bonnet strut. **See CHASSIS AND BODY, Repair.**
13. Remove bonnet lock RH or LH. **See CHASSIS AND BODY, Repair.**
14. Remove wheel arch liner - front. **See CHASSIS AND BODY, Repair.**
15. Remove front door assembly. **See CHASSIS AND BODY, Repair.**
16. Remove 'A' post trim. **See CHASSIS AND BODY, Repair.**
17. Remove fascia. **See CHASSIS AND BODY, Repair.**
18. Remove front wing.
19. Remove engine. **See Workshop Manual - ENGINE.**
20. Remove gearbox. **See Workshop Manual - GEARBOX.**

**Refit**



**NOTE: In this operation the valance and wheelarch is fitted in combination with a front sidemember.**

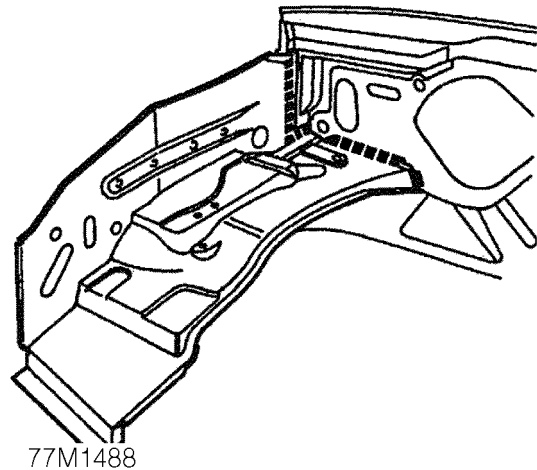

21. Prepare and clean panel joint faces. Punch or drill holes in new valance and wheelarch for plug welding as shown.
22. Reverse removal procedure.
23. Remove stands and lower vehicle.

## FRONT SIDEMEMBER

## Remove

1. Disconnect battery earth lead.
2. Raise front of vehicle.



**WARNING: Support on safety stands.**

3. Disconnect all ECUs.
4. Disconnect airbags and sensor system.
5. Remove airbag module. **See SUPPLEMENTARY RESTRAINT SYSTEM, Repair.**
6. Disconnect alternator.
7. Remove front bumper valance. **See CHASSIS AND BODY, Repair.**
8. Remove extension spoiler front bumper. **See CHASSIS AND BODY, Repair.**
9. Remove front grille. **See CHASSIS AND BODY, Repair.**
10. Remove headlamp. **See Workshop Manual - ELECTRICAL**
11. Remove bonnet. **See CHASSIS AND BODY, Repair.**
12. Remove bonnet strut. **See CHASSIS AND BODY, Repair.**
13. Remove bonnet lock RH or LH. **See CHASSIS AND BODY, Repair.**
14. Remove wheel arch liner - Front. **See CHASSIS AND BODY, Repair.**
15. Remove front door assembly. **See CHASSIS AND BODY, Repair.**
16. Remove 'A' post trim. **See CHASSIS AND BODY, Repair.**
17. Remove front wing.

## Refit

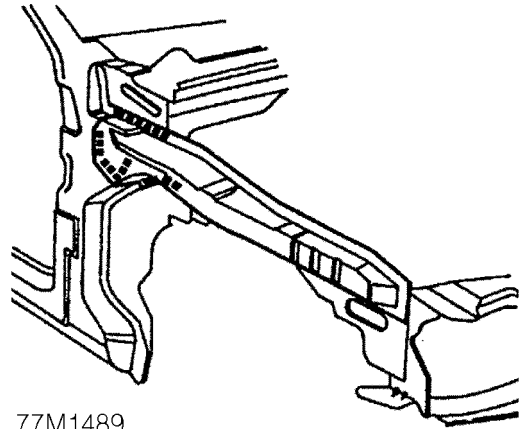

77M1489

18. Prepare and clean panel joint faces. Punch or drill holes in new front sidemember for plug welding as shown.



**WARNING: Remove ALL traces of adhesive from valance upper edge before plug welding.**

19. Reverse removal procedure.
20. Remove stands and lower vehicle.



**UPPER 'A' POST PANEL AND REPAIR PANEL**

**Remove**

1. Disconnect battery earth lead.
2. Raise front of vehicle.



**WARNING: Support on safety stands.**

3. Disconnect all ECUs.
4. Disconnect airbags and sensor system.
5. Remove both airbag modules. **See SUPPLEMENTARY RESTRAINT SYSTEM, Repair. See SUPPLEMENTARY RESTRAINT SYSTEM, Repair.**
6. Disconnect alternator.
7. Remove front bumper valance. **See CHASSIS AND BODY, Repair.**
8. Remove extension spoiler front bumper. **See CHASSIS AND BODY, Repair.**
9. Remove front grille. **See CHASSIS AND BODY, Repair.**
10. Remove windscreen. **See CHASSIS AND BODY, Repair.**
11. Remove headlamp. **See Workshop Manual - ELECTRICAL.**
12. Remove bonnet. **See CHASSIS AND BODY, Repair.**
13. Remove wheel arch liner - front. **See CHASSIS AND BODY, Repair.**
14. Remove front door assembly. **See CHASSIS AND BODY, Repair.**
15. Remove 'A' post trim. **See CHASSIS AND BODY, Repair.**
16. Remove fascia assembly. **See CHASSIS AND BODY, Repair.**
17. Remove front wing.

**Refit**



**NOTE:** In this operation, the 'A' post panel and repair panel are replaced in combination with the lower 'A' post and reinforcement. It is also necessary to remove the front sidemember for access.

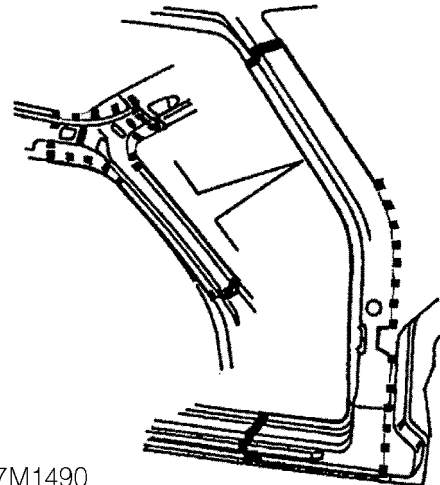

77M1490

18. Prepare and clean panel joint faces. Punch or drill holes in new panels for plug welding as shown.



**WARNING: Remove ALL traces of adhesive from outer face of 'A' post reinforcement before plug welding.**

Cut upper 'A' post and repair panel to form seam welded joints with existing panels.

19. Reverse removal procedure.
20. Remove stands and lower vehicle.

---

**LOWER 'A' POST AND REINFORCEMENT**

---

**Remove**

1. Disconnect battery earth lead.
2. Raise front of vehicle.



**WARNING: Support on safety stands.**

3. Disconnect all ECUs.
4. Disconnect airbags and sensor system.
5. Remove both airbag modules. **See SUPPLEMENTARY RESTRAINT SYSTEM, Repair. See SUPPLEMENTARY RESTRAINT SYSTEM, Repair.**
6. Disconnect alternator.
7. Remove front bumper valance. **See CHASSIS AND BODY, Repair.**
8. Remove extension spoiler front bumper. **See CHASSIS AND BODY, Repair.**
9. Remove front grille. **See CHASSIS AND BODY, Repair.**
10. Remove windscreen. **See CHASSIS AND BODY, Repair.**
11. Remove headlamp. **See Workshop Manual - ELECTRICAL.**
12. Remove bonnet. **See CHASSIS AND BODY, Repair.**
13. Remove wheel arch liner - front. **See CHASSIS AND BODY, Repair.**
14. Remove front door assembly. **See CHASSIS AND BODY, Repair.**
15. Remove 'A' post trim. **See CHASSIS AND BODY, Repair.**
16. Remove fascia assembly. **See CHASSIS AND BODY, Repair.**
17. Remove front wing.

**Refit**

**NOTE:** In this operation, the lower 'A' post and reinforcement are replaced in combination with the upper 'A' post and repair panel. It is also necessary to remove the front sidemember for access.

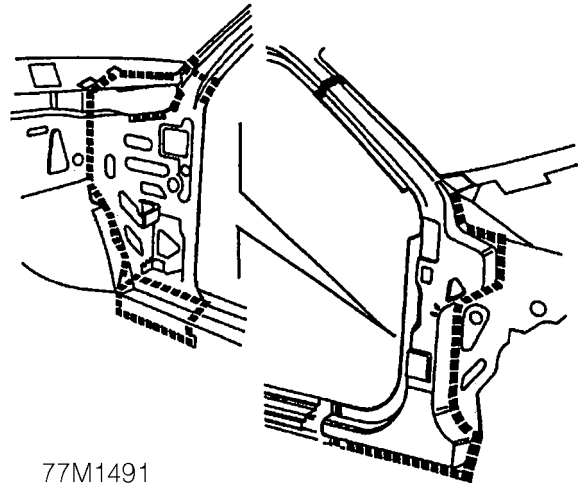

77M1491

18. Prepare and clean panel joint faces. Punch or drill holes in new panels for plug welding as shown.



**WARNING: Remove ALL traces of structural adhesive from dash reinforcement end flange before plug welding.**

Cut 'A' post reinforcement to form a seam welded butt joint with existing panel.

19. Reverse removal procedure.
20. Remove stands and lower vehicle.



---

**'BC' POST REPAIR PANEL**

---

Refit

**Remove**

1. Disconnect battery earth lead.
2. Raise side of vehicle.

**WARNING: Support on safety stands.**

3. Disconnect all ECUs.
4. Disconnect airbags and sensor system.
5. Remove both airbag modules. **See SUPPLEMENTARY RESTRAINT SYSTEM, Repair. See SUPPLEMENTARY RESTRAINT SYSTEM, Repair.**
6. Disconnect alternator.
7. Remove front seat. **See CHASSIS AND BODY, Repair.**
8. Remove seat belt - front. **See CHASSIS AND BODY, Repair.**
9. Remove front seat belt adjustable mounting. **See CHASSIS AND BODY, Repair.**
10. Remove B post trim. **See CHASSIS AND BODY, Repair.**
11. Remove rear door assembly. **See CHASSIS AND BODY, Repair.**

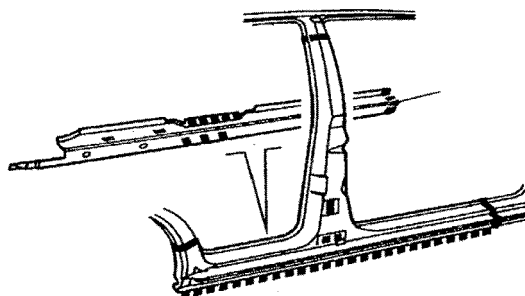

77M1492

12. Prepare and clean panel joint faces. Punch or drill holes in new 'BC' post repair panel for plug welding as shown. Cut panel to form seam welded butt joints with existing panel.
13. Reverse removal procedure.
14. Remove stands and lower vehicle.



---

**'BC' POST REINFORCEMENT**

---

**Remove**

1. Disconnect battery earth lead.
2. Raise side of vehicle.



**WARNING: Support on safety stands.**

3. Disconnect all ECUs.
4. Disconnect airbags and sensor system.
5. Disconnect alternator.
6. Remove front seat. *See CHASSIS AND BODY, Repair.*
7. Remove seat belt - front. *See CHASSIS AND BODY, Repair.*
8. Remove front seat belt adjustable mounting. *See CHASSIS AND BODY, Repair.*
9. Remove B post trim. *See CHASSIS AND BODY, Repair.*
10. Remove rear door assembly. *See CHASSIS AND BODY, Repair.*

**Refit**

**NOTE: In this operation, the 'B' post reinforcement and 'B' post repair panel are replaced in combination.**

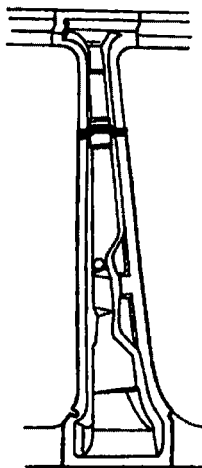

77M1493

11. Prepare and clean panel joint faces. Punch or drill holes in new panel for plug welding as shown. Cut new panel to form seam welded butt joint with existing panel.
12. Reverse removal procedure.
13. Remove stands and lower vehicle.



## 'BC' POST INNER PANELS

### Remove

1. Disconnect battery earth lead.
2. Raise side of vehicle.



**WARNING: Support on safety stands.**

3. Disconnect all ECUs.
4. Disconnect airbags and sensor system.
5. Disconnect alternator.
6. Remove front seat. *See CHASSIS AND BODY, Repair.*
7. Remove seat belt - front. *See CHASSIS AND BODY, Repair.*
8. Remove front seat belt adjustable mounting. *See CHASSIS AND BODY, Repair.*
9. Remove 'B' post trim. *See CHASSIS AND BODY, Repair.*
10. Remove rear door assembly. *See CHASSIS AND BODY, Repair.*

### Refit



**NOTE:** In this operation, the inner panels are replaced in combination with a 'B' post reinforcement and repair panel.

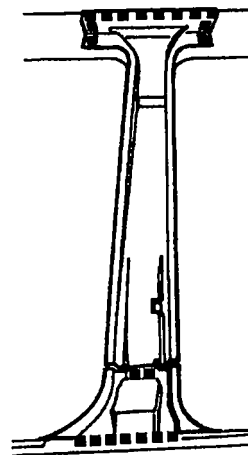

77M1494

11. Prepare and clean panel joint faces. Punch or drill holes in new 'BC' post inner panels for plug welding as shown.
12. Reverse removal procedure.
13. Remove stands and lower vehicle.

---

**ROOF ASSEMBLY**

---

**Remove**

1. Disconnect battery earth lead.
2. Disconnect all ECUs.
3. Disconnect airbags and sensor system.
4. Disconnect alternator.
5. Remove headlining - sliding roof. **See CHASSIS AND BODY, Repair.**
6. Remove sliding roof - electric. **See CHASSIS AND BODY, Repair.**
7. Remove windscreen. **See CHASSIS AND BODY, Repair.**
8. Remove front door assembly. **See CHASSIS AND BODY, Repair.**
9. Remove rear door assembly. **See CHASSIS AND BODY, Repair.**
10. Remove tailgate - upper. **See CHASSIS AND BODY, Repair.**
11. Remove seat belt - front. **See CHASSIS AND BODY, Repair.**
12. Remove front seat belt adjustable mounting. **See CHASSIS AND BODY, Repair.**
13. Remove A, B, D and E post trims. **See CHASSIS AND BODY, Repair.**
14. Remove sunroof drain tube - front. **See CHASSIS AND BODY, Repair.**
15. Remove sunroof drain tube - rear. **See CHASSIS AND BODY, Repair.**

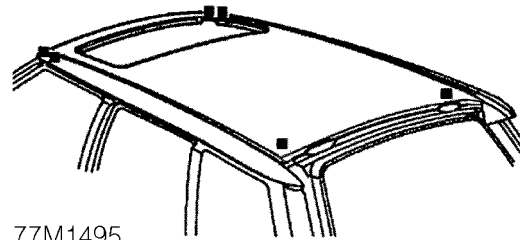
**Refit**

77M1495

16. Prepare and clean panel joint faces. Punch or drill holes in new roof assembly for plug welding as shown.



**WARNING: Remove ALL traces of adhesive from joints to cant rail front and rear corners before plug welding.**

17. Reverse removal procedure.



**OUTER REAR QUARTER PANEL**

**Remove**

1. Disconnect battery earth lead.
2. Raise rear of vehicle.



**WARNING: Support on safety stands.**

3. Disconnect all ECUs.
4. Disconnect airbags and sensor system.
5. Disconnect alternator.
6. Remove tailgate - lower. **See CHASSIS AND BODY, Repair.**
7. Remove parcel tray support. **See CHASSIS AND BODY, Repair.**
8. Remove parcel tray support trim. **See CHASSIS AND BODY, Repair.**
9. Remove 'E' post - exterior trim. **See CHASSIS AND BODY, Repair.**
10. Remove D and E post trims. **See CHASSIS AND BODY, Repair.**
11. Remove wheel arch liner - rear. **See CHASSIS AND BODY, Repair.**
12. Remove rear quarter light. **See CHASSIS AND BODY, Repair.**
13. Remove quarter panel rubbing strips. **See CHASSIS AND BODY, Repair.**
14. Remove rear bumper valance. **See CHASSIS AND BODY, Repair.**
15. Remove rear seat belt - left hand or right hand. **See CHASSIS AND BODY, Repair. See CHASSIS AND BODY, Repair.**
16. Remove sunroof drain tube - rear. **See CHASSIS AND BODY, Repair.**

**Refit**

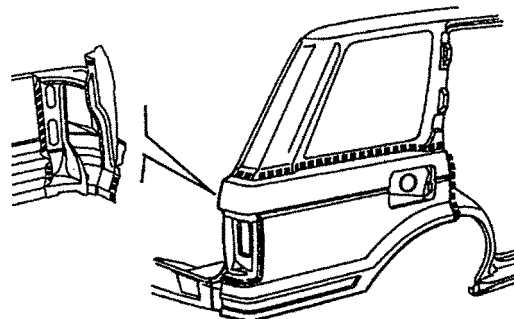

77M1496

17. Prepare and clean panel joint faces. Punch or drill holes in new panel for plug welding as shown. Apply structural adhesive at joint to outer wheelarch. **See Corrosion protection.**



**WARNING: Remove ALL traces of adhesive from joint to lower panel before plug welding.**

18. Reverse removal procedure.
19. Remove stands and lower vehicle.

---

**INNER REAR QUARTER PANEL**

---

**Remove**

1. Disconnect battery earth lead.
2. Raise rear of vehicle.



**WARNING: Support on safety stands.**

3. Disconnect all ECUs.
4. Disconnect airbags and sensor system.
5. Disconnect alternator.
6. Remove tailgate - lower. *See CHASSIS AND BODY, Repair.*
7. Remove tailgate - upper. *See CHASSIS AND BODY, Repair.*
8. Remove parcel tray support and trim. *See CHASSIS AND BODY, Repair.*
9. Remove 'E' post - exterior trim. *See CHASSIS AND BODY, Repair.*
10. Remove 'D' and 'E' post trims. *See CHASSIS AND BODY, Repair.*
11. Remove wheel arch liner - rear. *See CHASSIS AND BODY, Repair.*
12. Remove rear quarterlight. *See CHASSIS AND BODY, Repair.*
13. Remove appropriate rubbing strip. *See CHASSIS AND BODY, Repair.*
14. Remove rear bumper valance. *See CHASSIS AND BODY, Repair.*
15. Remove rear seat belt - left hand or right hand. *See CHASSIS AND BODY, Repair. See CHASSIS AND BODY, Repair.*
16. Remove sunroof drain tube - rear. *See CHASSIS AND BODY, Repair.*

**Refit**

**NOTE: In this operation, the inner rear quarter panel, outer quarter and rear quarter repair panel are replaced in combination .**

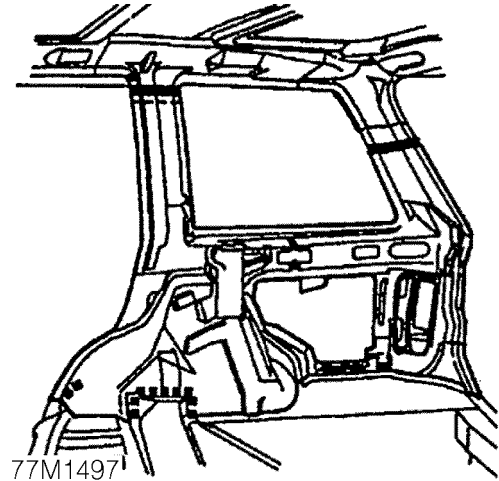

17. Prepare and clean panel joint faces. Apply structural adhesive at joint to floor at lower edge of wheelarch. *See Corrosion protection.* Plug weld at joints to floor using holes left by spot weld cutter. Cut inner rear quarter to form seam welded butt joints with existing panel.



**WARNING: Remove ALL traces of adhesive from joint to floor inside vehicle before plug welding.**

18. Reverse removal procedure.
19. Remove stands and lower vehicle.



**REAR QUARTER REPAIR PANEL**

**Remove**

1. Disconnect battery earth lead.
2. Raise rear of vehicle.



**WARNING: Support on safety stands.**

3. Disconnect all ECUs.
4. Disconnect airbags and sensor system.
5. Disconnect alternator.
6. Remove tailgate - lower. *See CHASSIS AND BODY, Repair.*
7. Remove tailgate - upper. *See CHASSIS AND BODY, Repair.*
8. Remove parcel tray support and trim. *See CHASSIS AND BODY, Repair.*
9. Remove 'E' post - exterior trim. *See CHASSIS AND BODY, Repair.*
10. Remove 'D' and 'E' post trims. *See CHASSIS AND BODY, Repair.*
11. Remove wheel arch liner - rear. *See CHASSIS AND BODY, Repair.*
12. Remove rear quarterlight. *See CHASSIS AND BODY, Repair.*
13. Remove rear quarter rubbing strip. *See CHASSIS AND BODY, Repair.*
14. Remove rear bumper valance. *See CHASSIS AND BODY, Repair.*
15. Remove rear seat belt - left hand or right hand. *See CHASSIS AND BODY, Repair.*
16. Remove sunroof drain tube - rear. *See CHASSIS AND BODY, Repair.*

**Refit**



**NOTE:** In this operation, the rear quarter repair panel, outer quarter and rear quarter repair panel are replaced in combination.

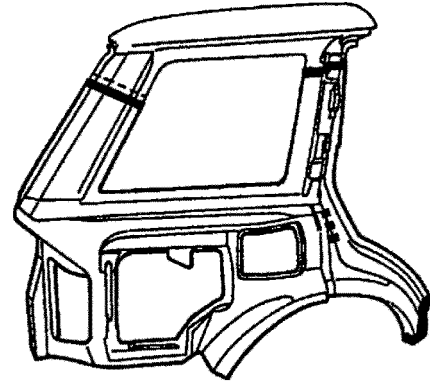

77M1498

17. Cut new rear quarter repair panel to form MIG welded butt joints with existing panels.



**CAUTION: Do NOT cut into the inner quarter during this operation.**

18. Reverse removal procedure.
19. Remove stands and lower vehicle.

**LOAD FLOOR SIDE****Remove**

1. Disconnect battery earth lead.
2. Raise rear of vehicle.



**WARNING: Support on safety stands.**

3. Disconnect all ECUs.
4. Disconnect airbags and sensor system.
5. Disconnect alternator.
6. Remove tailgate - lower. *See CHASSIS AND BODY, Repair.*
7. Remove rear bumper valance. *See CHASSIS AND BODY, Repair.*

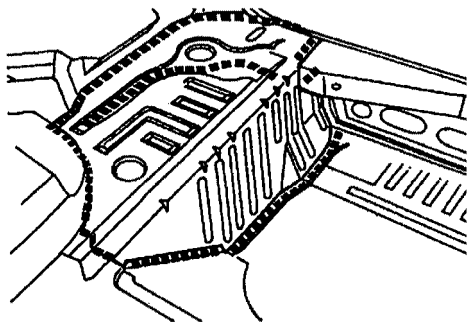
**Refit**

77M1502

8. Prepare and clean panel mating faces. Punch or drill holes in new rear floor panel for plug welding as shown. Plug weld also to spare wheel well edges using holes left by spot weld cutter.
9. Reverse removal procedure.
10. Remove stands and lower vehicle.

**REAR CROSSMEMBER PANEL****Remove**

1. Disconnect battery earth lead.
2. Raise rear of vehicle.



**WARNING: Support on safety stands.**

3. Disconnect all ECUs.
4. Disconnect airbags and sensor system.
5. Disconnect alternator.
6. Remove tailgate - lower. *See CHASSIS AND BODY, Repair.*
7. Remove rear bumper valance. *See CHASSIS AND BODY, Repair.*

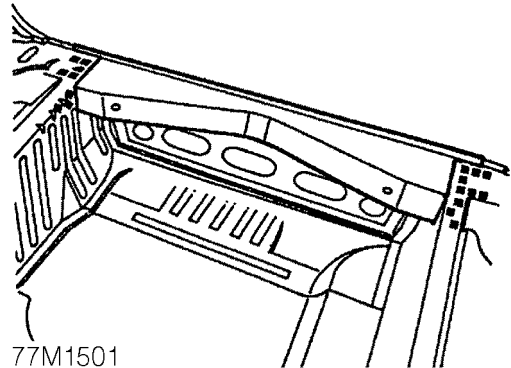
**Refit**

77M1501

8. Prepare and clean panel joint faces. Punch or drill holes in new rear crossmember panel for plug welding as shown.
9. Reverse removal procedure.
10. Remove stands and lower vehicle.



**REAR FLOOR EXTENSION PANEL**

**Remove**

1. Disconnect battery earth lead.
2. Raise rear of vehicle.



**WARNING: Support on safety stands.**

3. Disconnect all ECUs.
4. Disconnect airbags and sensor system.
5. Disconnect alternator.
6. Remove tailgate - lower. *See CHASSIS AND BODY, Repair.*
7. Remove rear bumper valance. *See CHASSIS AND BODY, Repair.*

**Refit**

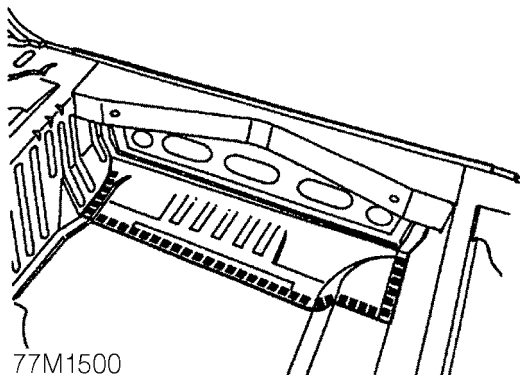

77M1500

8. Prepare and clean panel joint faces. Punch or drill holes in new rear crossmember extension panel for plug welding as shown.
9. Reverse removal procedure.
10. Remove stands and lower vehicle.

**SPARE WHEEL CLOSING PANEL**

**Remove**

1. Disconnect battery earth lead.
2. Disconnect all ECUs.
3. Disconnect airbags and sensor system.
4. Disconnect alternator.
5. Remove rear seat belt - left hand. *See CHASSIS AND BODY, Repair.*
6. Remove rear seat belt - right hand. *See CHASSIS AND BODY, Repair.*
7. Remove rear seatbelt - centre. *See CHASSIS AND BODY, Repair.*

**Refit**

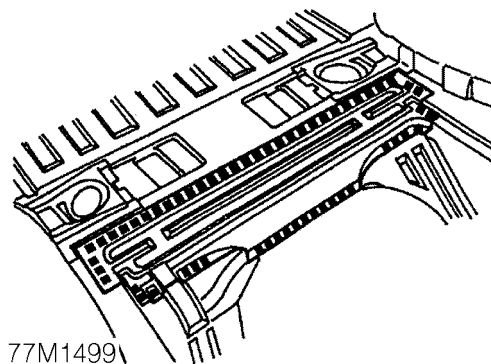

77M1499

8. Prepare and clean panel joint faces. Punch or drill holes in new spare wheel closing panel for plug welding as shown.
9. Reverse removal procedure.



---

**LOWER PANEL**

---

**Remove**

1. Disconnect battery earth lead.
2. Disconnect all ECUs.
3. Disconnect airbags and sensor system.
4. Disconnect alternator.
5. Remove tailgate - lower. *See CHASSIS AND BODY, Repair.*
6. Remove tailgate striker. *See CHASSIS AND BODY, Repair.*
7. Remove rear bumper valance. *See CHASSIS AND BODY, Repair.*

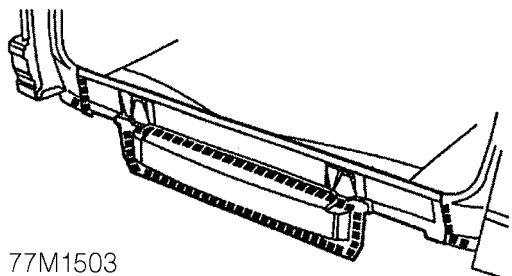
**Refit**

8. Prepare and clean panel joint faces. Punch or drill holes in new lower panel for plug welding as shown.



**WARNING:** remove ALL traces of adhesive from joints to quarter panels before plug welding.

9. Reverse removal procedure.